



GLOBE AIRMOTORS B.V.



YOUR GLOBAL FORCE IN AIR POWER







THE GLOBE AIRMOTORS COMPANY

GLOBE Airmotors was founded in 1986 and designs, manufactures, sells and modifies air motors of many styles.

GLOBE Airmotors has an enthusiastic team, with a wealth of experience, ready at your disposal. Service and short delivery times are very important according to GLOBE Airmotors. Short delivery times can only be maintained when there is a stock that is sufficient to fulfil the need for quick air motor demands. As a result of this, standard products can be delivered from stock at all times.

GLOBE Airmotors keeps the production within its own organization, making it possible for customers to come up with unique specifications. New products are being designed and tested at the workshop before they reach each customer. Part of GLOBE' service are fast answers to questions asked by customers.



ISO CERTIFICATION

Along with service and short delivery times, GLOBE Airmotors finds overall quality very important. We are ISO 9001 certified to maintain our quality at it's best.

ATEX

Air motors and other pneumatic drives are often used in explosion risk environments such as mines. To ensure that GLOBE products are allowed to be used at these hazardous environments, GLOBE obtained ATEX certificates for all their air motors and gearboxes. Delivery is possible with ATEX II cat. 2 G&D T5 and ATEX I M2 (Mining).

For more information you can also go to our website:

www.GLOBE-benelux.nl

Drawings and performances are also available on our website.

ACKNOWLEDGEMENT

The Pictures in this GLOBE catalogue are made possible because of the following companies:

Duits Engineering, Zutphen (NL)	PAGE 2
Poly-clip, Turnhout (BE)	PAGE 6
Het Muziektheater, Amsterdam (NL)	PAGE 11
Hydrauvision, Schoondijke (NL)	PAGE 13
SPGPrints B.V., Boxmeer (NL)	PAGE 15
Dromec, Rhenen (NL)	PAGE 54, 59, 107
Bohr Instrument Services BV, Veenoord (NL)	PAGE 16, 20
Gritco Equipment BV, Ridderkerk (NL)	PAGE 51
Marotechniek BV, Zutphen (NL)	PAGE 140
BPL Roosen, Haelen (NL)	PAGE 172, 186

CONTENTS

INTRODUCTION AIR MOTORS	PAGE 07
AIR MOTOR SELECTION GUIDE	PAGE 09
HOW TO CONTROL AND USE AN AIR MOTOR?	PAGE 10
APPLICATIONS OF AIR MOTORS	PAGE 17
GLOBE VANE AIR MOTORS	PAGE 19
NON LUBRICATED VANE AIR MOTORS	PAGE 37
GLOBE GEARED VANE AIR MOTORS	PAGE 55
GLOBE PFG-RED PLANETARY GEARED VANE MOTORS	PAGE 80
VANE AIR MOTORS WITH BRAKE	PAGE 105
DIRECT CONTROLLED VANE AIR MOTORS	PAGE 108
AIR MOTOR UNIT FOR WINCHES	PAGE 123
COMPACT VANE AIR MOTORS	PAGE 131
RADIAL PISTON (RM) AIR MOTORS	PAGE 141
COMPACT PISTON AIR MOTORS	PAGE 172
GLOBE PNEUMATIC BRAKES - BN SERIES	PAGE 187
WINCH SYSTEM	PAGE 191
STAINLESS STEEL MOTORS AND ACCESSORIES	PAGE 197

'Although the information contained in this brochure has been compiled with the utmost care, it is subject to change without notice. It is therefore your responsibility to verify its accuracy before acting on it'



INTRODUCTION AIR MOTORS

GLOBE Airmotors sells, manufactures and modifies a large variety of air motors and gearboxes suitable for all your needs.

Air motors offer a unique drive and incorporate advantages not found in other prime movers. Air motors are impossible to ignore for any engineer, because of the strong and reliable power they produce. Due to the wide range of products that GLOBE Airmotors has, applicable for a lot of different purposes.

GLOBE Airmotors has a wide selection of air motors each with its own advantages, such as the [GLOBE Piston Air Motors](#), [GLOBE Vane Air Motors](#), [GLOBE-Archimedes Compact Vane Air motors](#), the [GLOBE Compact Piston Airmotors](#) and all options needed for Air motors.



AIR MOTOR SELECTION GUIDE

VANE AIR MOTORS

The vane air motors are the most widely used design of air motors. They are available in a broad range of power and can operate in any position. The vane air motors prove themselves to be much lighter and more compact compared to piston air motors of similar power. A combination of a GLOBE vane air motor with a large variety of gearboxes is possible when lower speed and/or higher torque is demanded for the application. The most typical vane air motor applications are:

- Mixing equipment
- Ventilators
- Hoists
- Winches
- Pump drives
- Conveyor belts
- Turntables
- Packing machines
- After coolers

COMPACT VANE AIR MOTORS

The compact vane air motors are motors that have incorporated reduction units. Due to the wide range of gear ratios the compact vane air motors are suitable in many different applications. The compact vane air motors are known for delivering very high speed and very high torque compared to the compact build of the motor.

Compact vane air motors prove themselves in handheld applications, pipe cleaners and lots of other different industries which require compact build and strong reliable motors.

COMPACT PISTON AIR MOTOR

The GLOBE compact piston air motors are used in numerous applications. Due to its unique design the compact piston air motor are most suitable for light and medium duties at low speed operations. A combination of a GLOBE compact piston air motor with a large variety of gearboxes is possible when even lower speed and/or higher torque is demanded for the application. The most typical compact piston air motor applications are:

- Mixing equipment
- Winding equipment
- Conveyor belts
- Hose reels
- Turntables
- Packing machines
- Cap screwing machines

PISTON AIR MOTOR

The GLOBE piston air motor are heavy duty air motors. This radial piston air motor combines a large variable speed with high power and torque. The motors have either four or five pistons with oil bath lubrication and their design allows them to deliver the highest power in air motors. A combination of a GLOBE piston air motor with a large variety of gearboxes is possible when lower speed and/or higher torque is demanded for the application.

The piston air motor is applicable in many situations and is commonly used in winches, offshore and other heavy duty applications.

HOW TO CONTROL AND USE AN AIR MOTOR

SPEED REGULATION

Controlling the performance of an air motor is done by regulating the air supply. This is relatively low cost and simple. The methods to regulate the air supply are throttling and pressure regulation.

TROTTLING METHODS

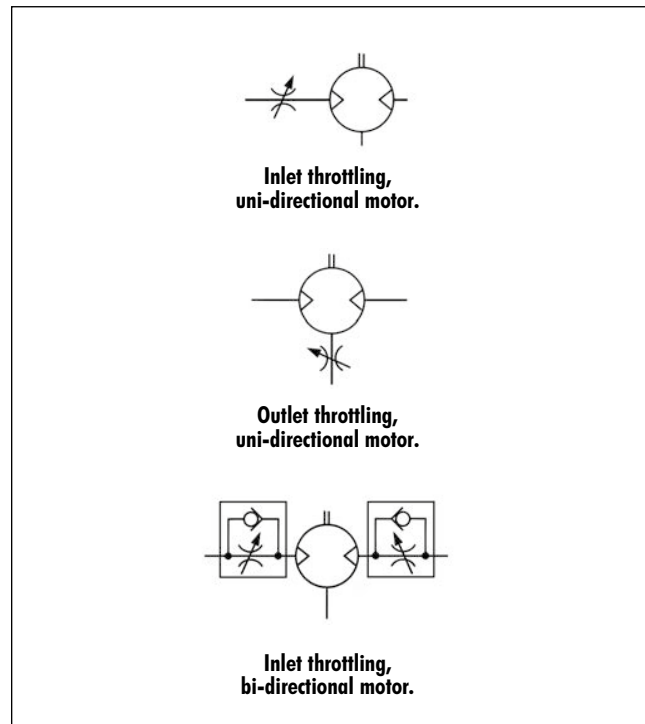

THROTTLING

The air flow is controlled by placing a flow control valve at the inlet port or the outlet port of the air motor. Throttling will reduce the maximum speed of the motor but will not affect the starting performance; the air pressure is unaffected at low flow conditions i.e. starting. Please consult the chapters of the different air motors for the correct throttling graphs and methods'.

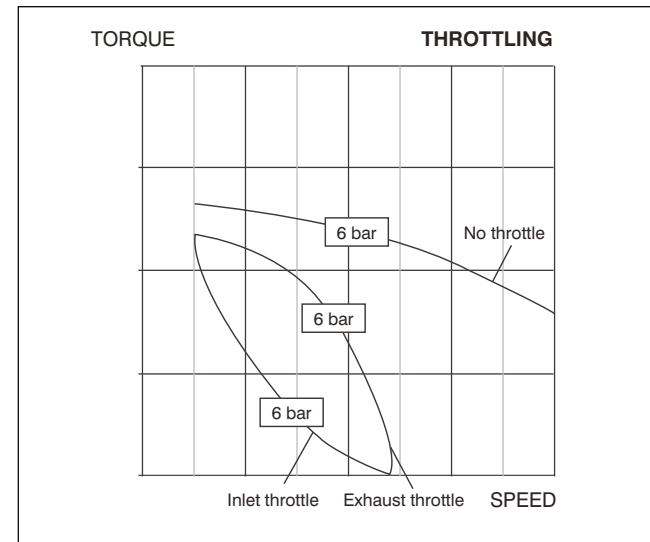

PRESSURE REGULATOR

The speed and power can also be reduced by installing a pressure regulator on the incoming air supply. The pressure regulator reduces the air pressure to the motor. A pressure regulator is always fitted on the inlet port. By using a pressure regulator the torque on the output shaft will be affected, starting torque is best controlled with this method.

PRESSURE REGULATING METHOD

When both the speed and the torque are to be controlled the best configuration is to use a pressure regulator in the air line to the motor and a flow control valve on the outlet port. This way every point in the torque-speed graph can be set accurately.

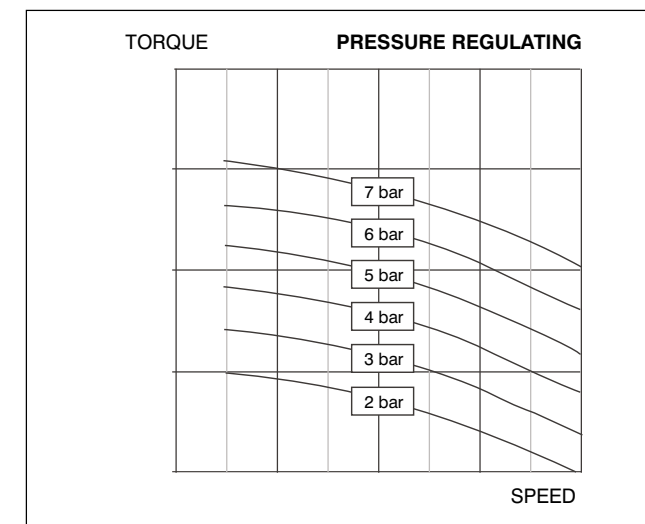
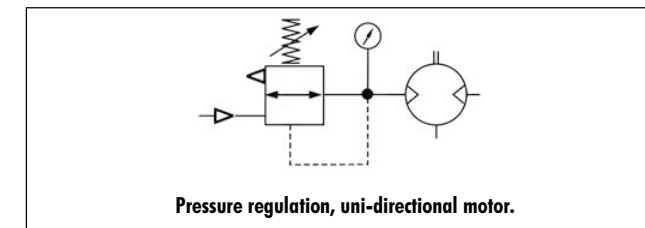

DIRECTIONS OF ROTATION

The GLOBE air motor can be used both as a uni-directional and as a bi-directional air motor. When the air motor is used in a non-reversible application, it is sufficient to use a 2/2 or a 3/2 valve. For the reversible motor you can use either a 5/3 or two 3/2 valve to gain directional control.

UNI - DIRECTIONAL

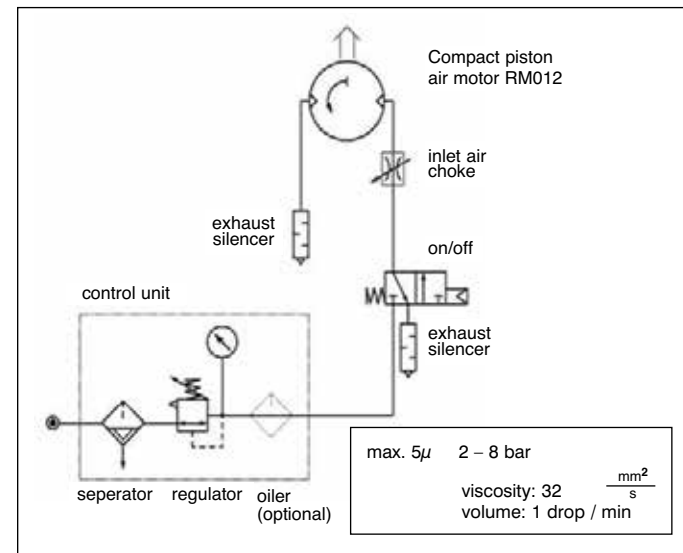

BI - DIRECTIONAL

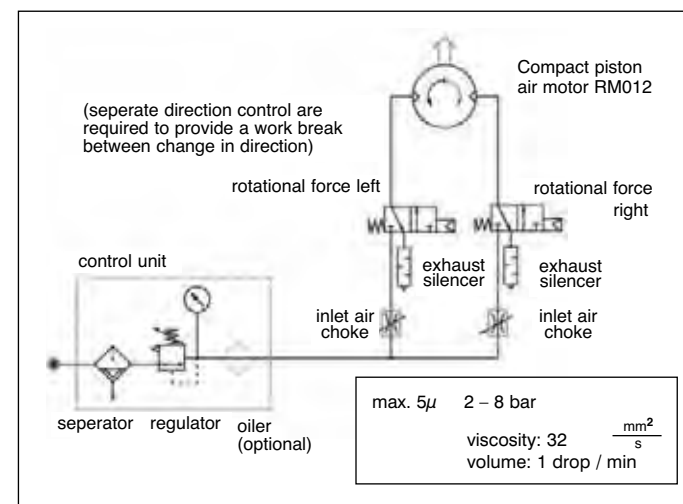

AIR SUPPLY

AIR QUALITY

To ensure optimal working conditions for the GLOBE air motor, the air supply must be dry, filtered and lubricated. A 5 micron filter or better is recommended for the compact piston air motors and the compact vane air motors, a 64 microns filter or better is recommended for the vane air motors. The GLOBE air motor should be lubricated sufficiently. Oilless operations are possible in certain applications.

AIR LINE RESTRICTIONS

Air line restrictions on the inlet side of the motor will result in performance loss. Therefore it is important to make sure that the desired air pressure is available at the motor during operation. The pressure reading at the compressor or pressure regulator may be different than the pressure available at the motor. Performance loss can also occur by an exhaust restriction generating back pressure on the outlet side of the motor. An insufficiently sized silencer, valve or coupling is usually the cause.

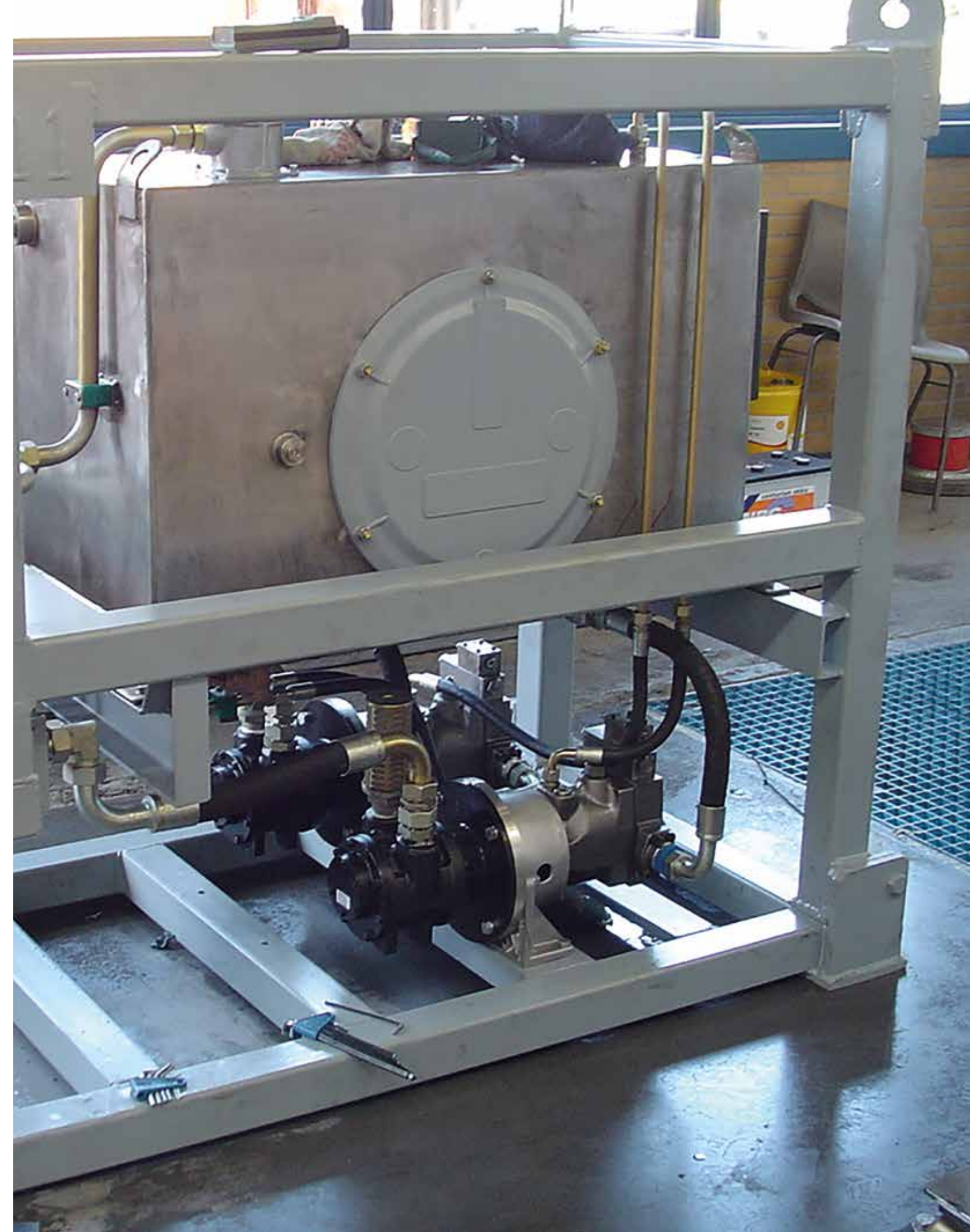

MOTOR SELECTION (EXAMPLE BASED ON V2)

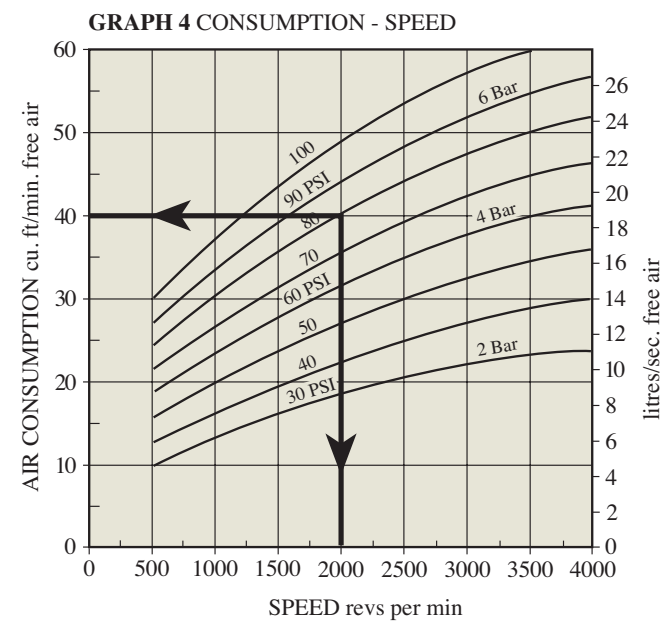
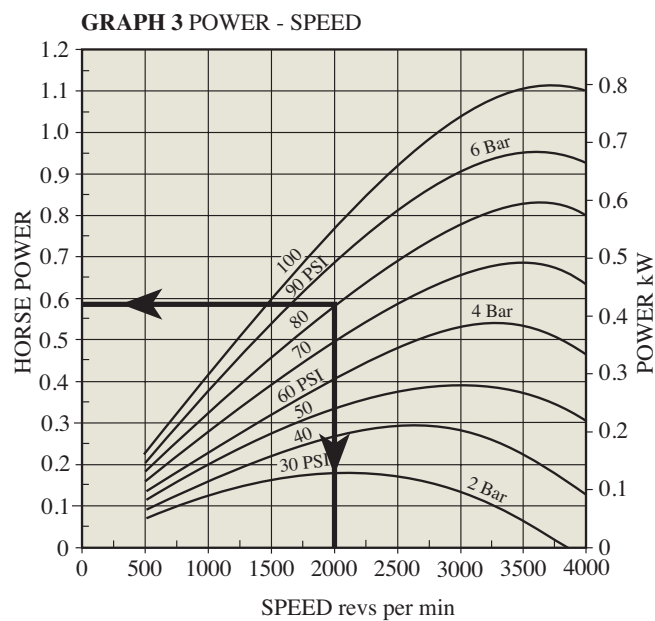
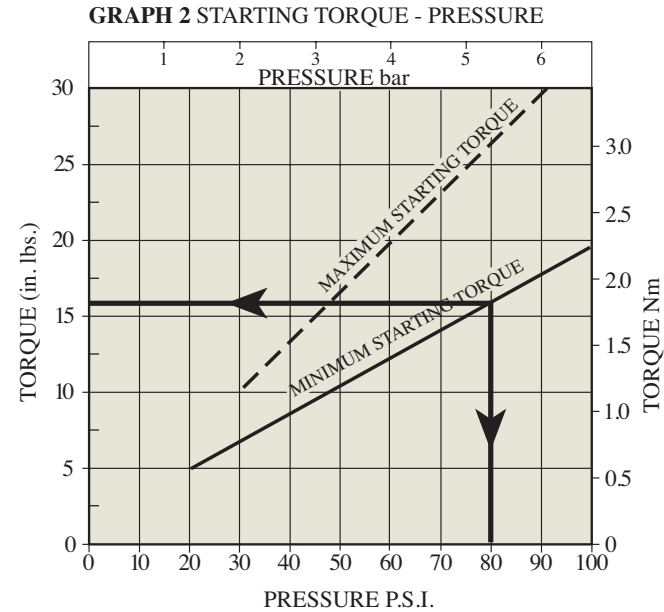
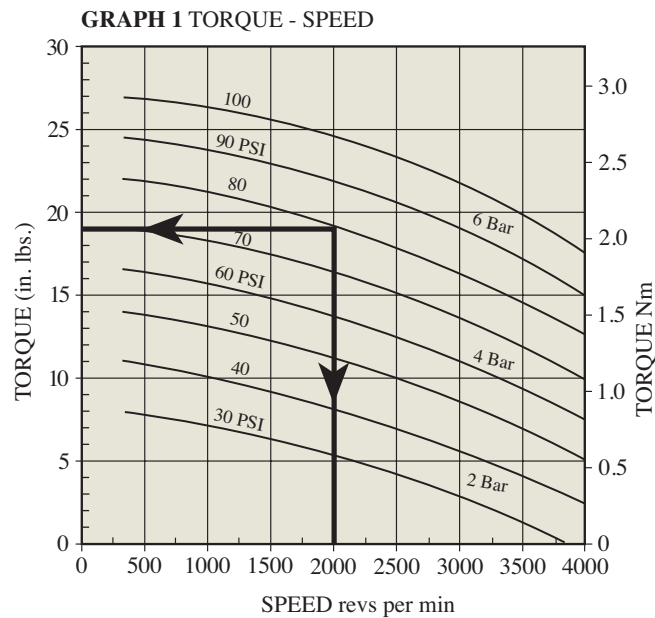

MOTOR SELECTION

Motor performance can be derived from the above graphs as in the examples shown. Where motors are not required to start under load, such as fan drives, selection may be made using either Graph 1 or Graph 3 using the required running torque or power only. For applications where the motor starts under load, such as hoists, winches or track drives, the starting torque in Graph 2 must also be considered.

1. Running torque example: V2 at 80 psi gives 19 lbf.ins. torque at 2000 rpm.
2. Starting torque example: V2 at 80 psi gives 16 lbf.ins. torque.
3. Output power example: V2 at 80 psi gives 0.6 hp at 2000 rpm.
4. Air consumption example: V2 at 80 psi and 2000 rpm requires 40 u.ft./min. free air.

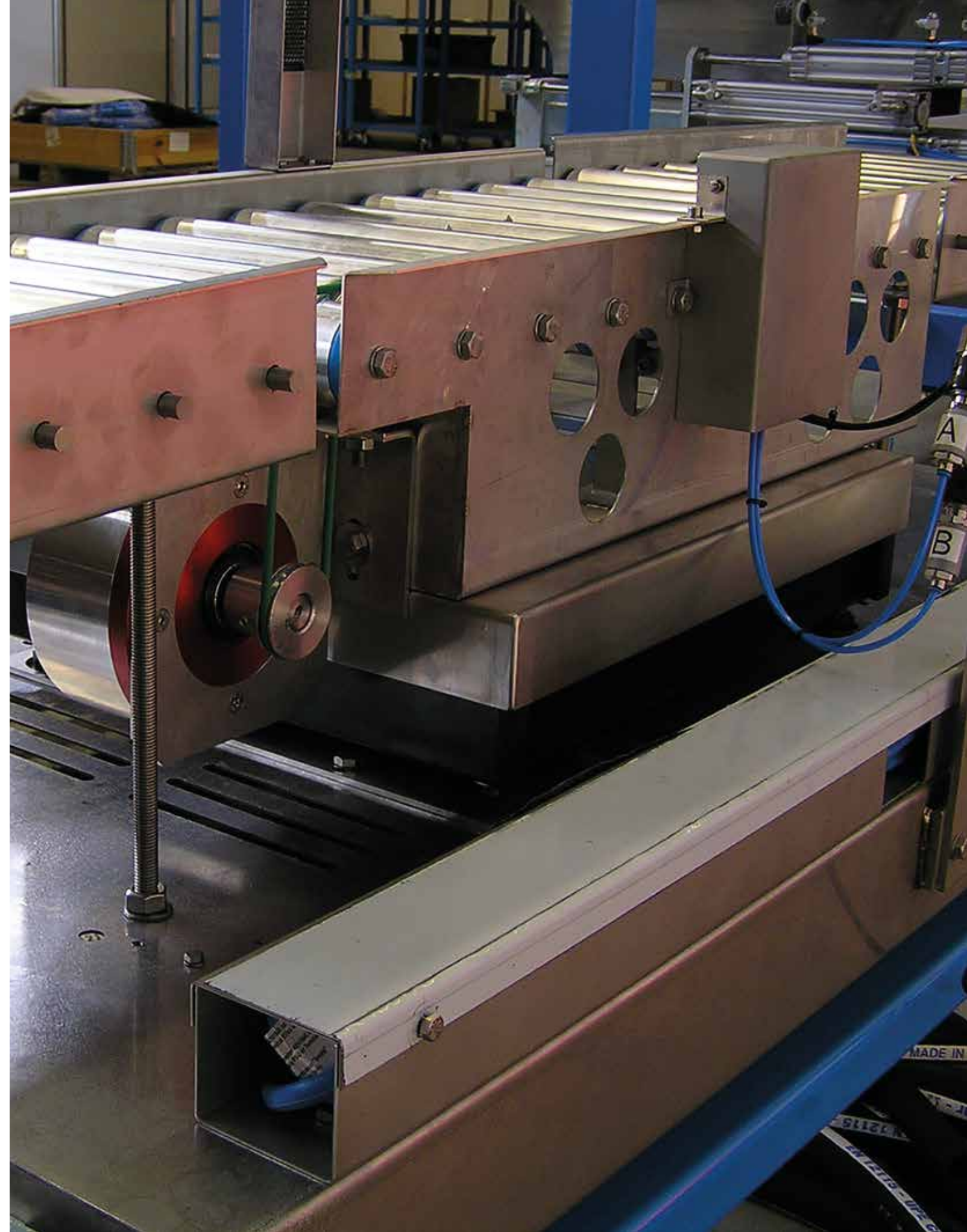



APPLICATIONS OF AIR MOTORS

GLOBE air motors are being used in a large variety of applications. Here you will find some examples of the most common applications in which our air motors are being used.

WINCHES

GLOBE air motors are commonly used in in winching applications. Due to our broad range of gearboxes, brakes and control valve possibilities our air motors are used on many different winches. Please contact us for the possibilities or more information.

AFTER COOLERS

The GLOBE air motors are also used in after coolers. Because our air motors can run in many different speeds they prove themselves to be a perfect match with for after coolers.

CONVEYOR BELTS

Many companies use our air motors for the drive of their conveyor belts. In combination with a gearbox, brake or control valve the options are many.

MIXING APPLICATIONS

We find our air motors being used in many different mixing applications. That is one of the reasons we have stainless steel air motors or/and motors which can run without lubrication.

PUMP DRIVES

Pumps are also often being driven by our air motors. Our large scope of available power, torque and IEC or NEMA flanges makes our air motors user-friendly in many different situations.

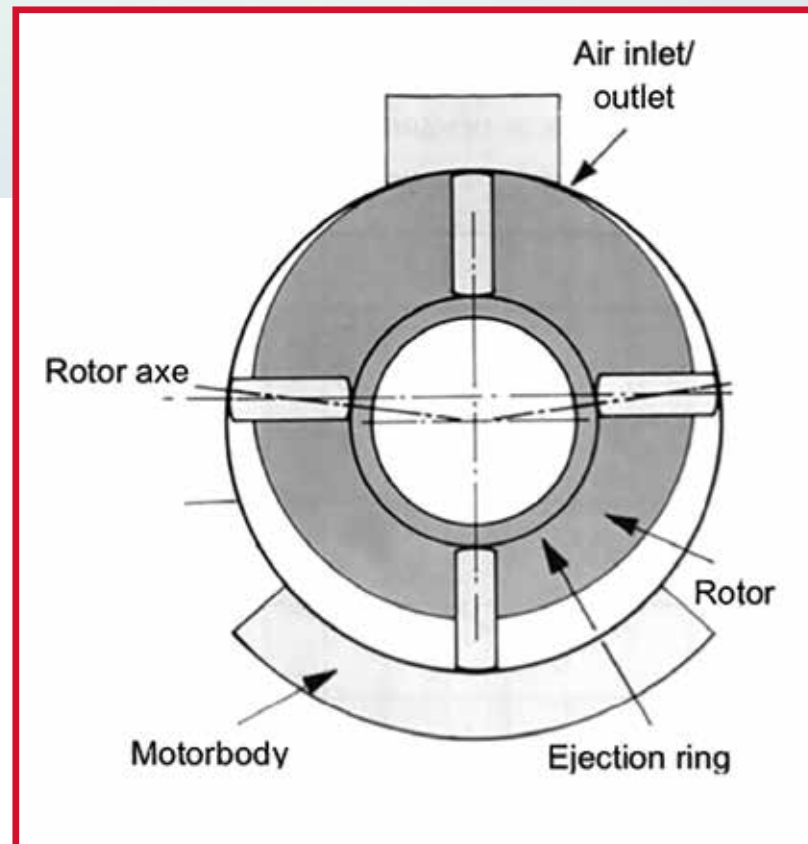

GLOBE VANE AIR MOTORS

ADVANTAGES

Vane air motors offer a unique form of drive and incorporate advantages not found in other prime movers.

These advantages include:

- Simple and inexpensive variable speed and torque control with a flow control valve and/or pressure regulator.
- Intrinsically safe for explosion proof environments. All GLOBE vane air motors are certified according to the European Explosion Directive ATEX II cat. 2 G&D T5 and ATEX I M2.
- Air motors can be stalled indefinitely under load. They will not over heat or burn out.
- Instantly reversible, operated with a simple control valve.
- Controllable over a wide speed range.
- Resistant to warm, dirty and damp conditions. GLOBE vane air motors can be used in ambient temperatures up to 80 °C.
- Minimal maintenance because of simple design which results in less downtime.
- Air motors are compact and light weight compared to equivalent electric motors.
- High reliability and little wear thanks to the low number of moving parts.
- No shock start up which improves the life span of your equipment.
- Variety of mountings which include foot, face, NEMA flanges and IEC flanges.

WHY CHOOSE A GLOBE VANE AIR MOTOR?

NO PINS OR SPRINGS.

The GLOBE blade ejection system consists of an ejection ring which maintains a constant positive blade contact with the motor body. This guarantees the blade position on start up, preventing free air flow from port to port and ensuring the motor produces its rated starting torque. The ejection ring design removes the requirement for pins or springs, the result is low vane wear and a high motor reliability.

THE GLOBE vane air motors can be supplied with a wide range of gearboxes, such as planetary, helical, bevel and worm gears, directly coupled to the motor.

Suitable for running on natural sweet gas and other gasses.

Oil-less function possible under certain operating conditions.

Robust design for operation in harsh environments. Available in a variety of motor interfaces including foot, face, NEMA and IEC flanges. Special adaptations are available on request, consult GLOBE Airmotors BV or your local distributor for more information.



ORDERING CODES

Mounting position

A	Foot, Face or NEMA Flange
S	Metric Flange

Mounting type

J&X	Foot, face mounting
C	Flange mounting (IEC, NEMA)

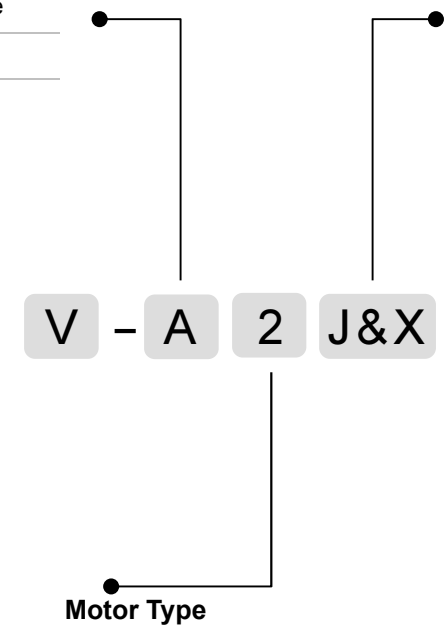

Motor Type

1	0,44 kW / 0,6 hp (only VA1J&X available)
2	0,82 kW / 1,1 hp
4	2,1 kW / 2,8 hp
6	3,4 kW / 4,6 hp
8	5,4 kW / 7,2 hp
10	9,5 kW / 12,8 hp
12	14 kW / 19,1 hp (only in available in flange models)

Use the ordering codes to create the GLOBE Vane Air Motor you want.

For example: VA4J&X or VS8C (the VS types are only suitable with a C at the end of the code)

DIMENSIONS V1

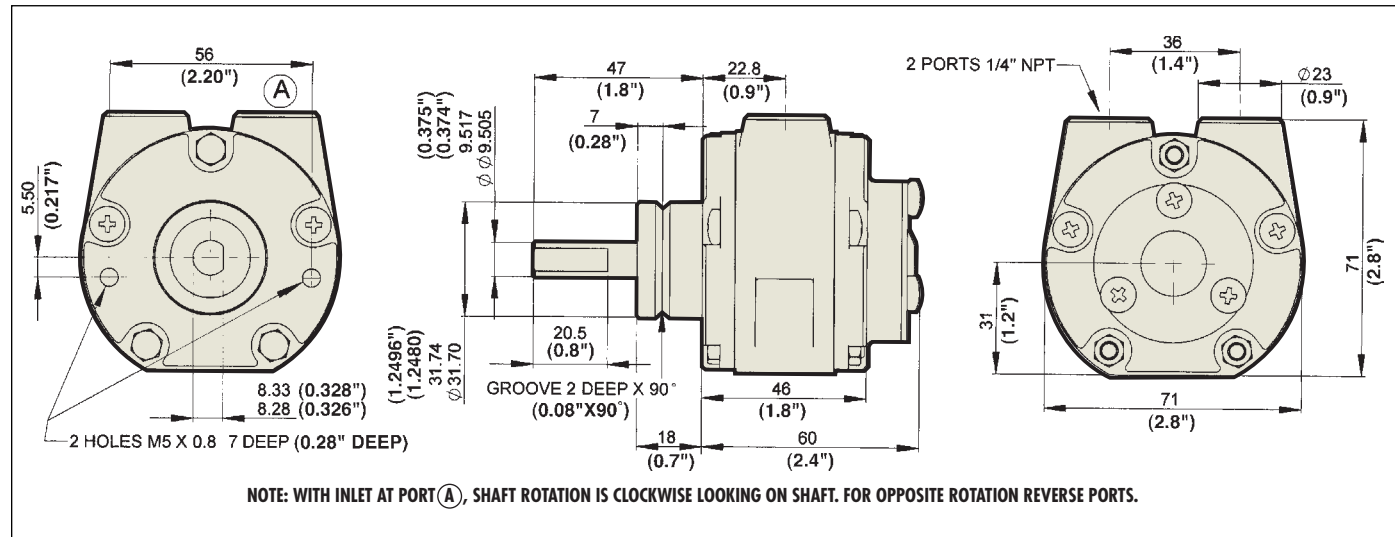

PERFORMANCE V1 | 0 - 0.6 HP/0.44 KW REVERSIBLE

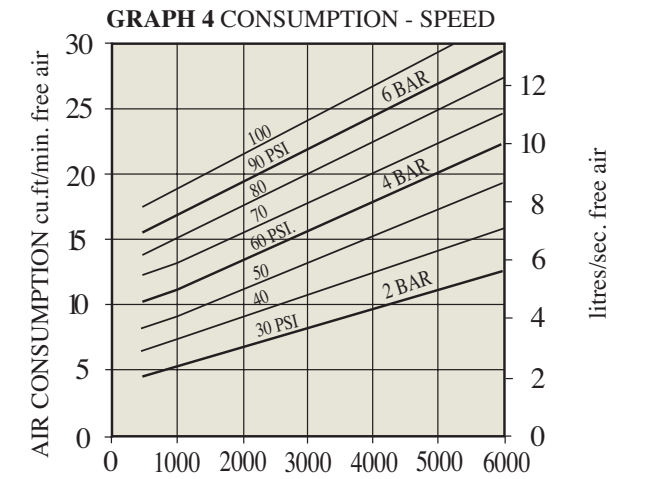
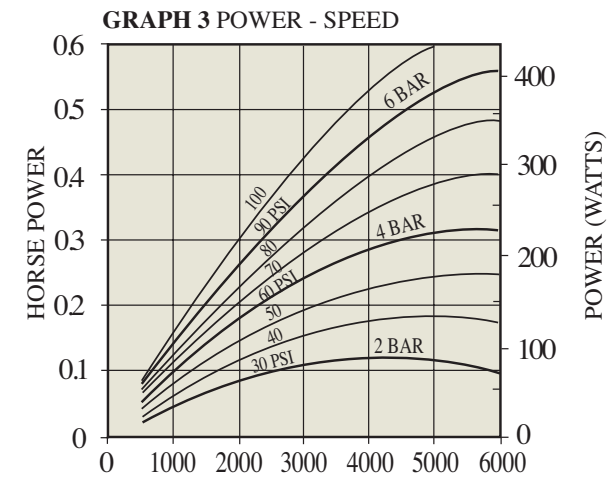
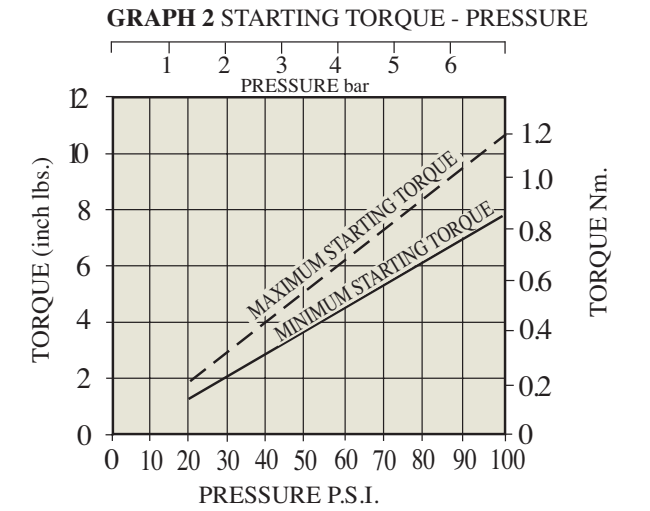
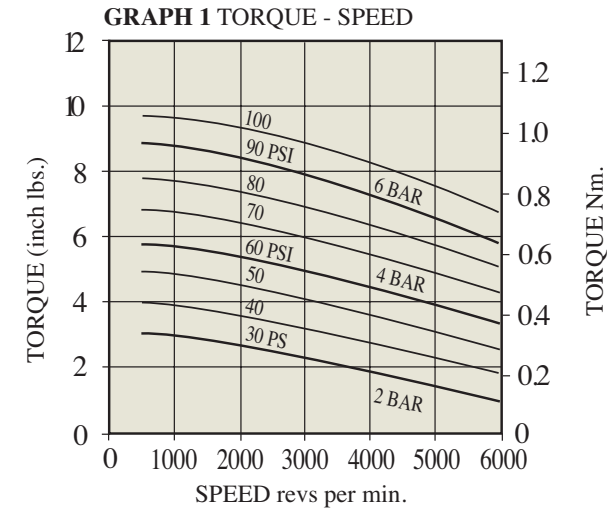

ATTITUDE:

The motor can be operated in all orientations.

AIRLINE FILTRATION AND LUBRICATION:

Use 64 micron filtration or better. Choose a lubricator suitable for the flow required. Prior to start up, inject oil into the inlet port.

LUBRICATOR DROP RATE:

4-5 drops per minute continuous operation.
9-12 drops per minute intermittent operation.

POLAR MOMENT OF INERTIA:

0.16 lb.ins² (460 g.cm²).

MAXIMUM OVERHUNG FORCE ON SHAFT:

4 lbf (18N) Axial loads should be kept to a minimum. Consult your GLOBE Distributor.

MAXIMUM TEMPERATURES:

-4° to +176° Fahrenheit. (-20° to +80°C)
Muffler supplied with motor.

DIMENSIONS V2

MODEL VA2C Nema 56C configuration

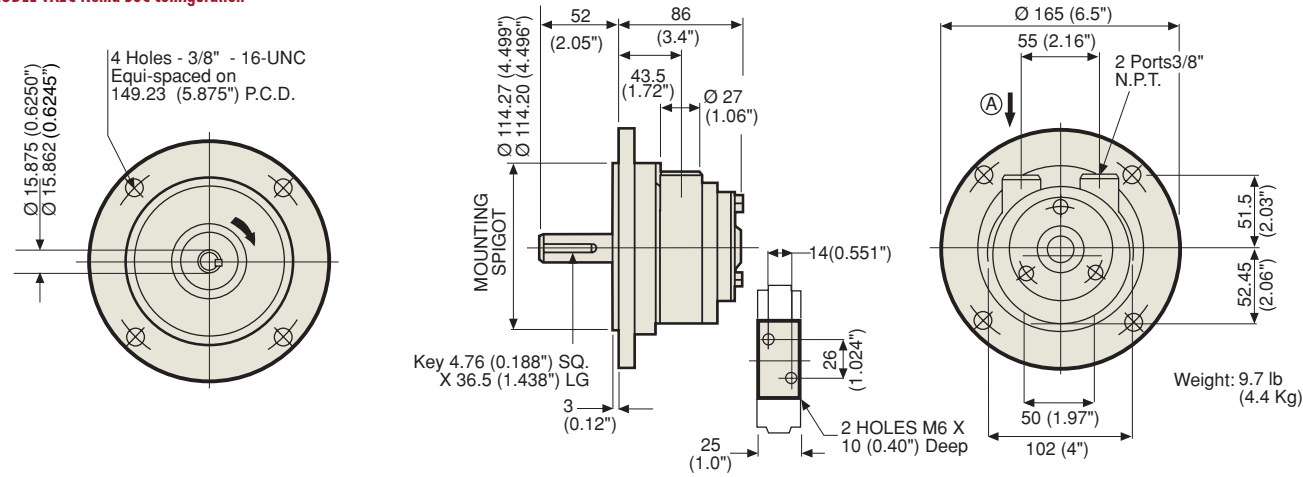

MODEL VA2J Foot Mounting configuration

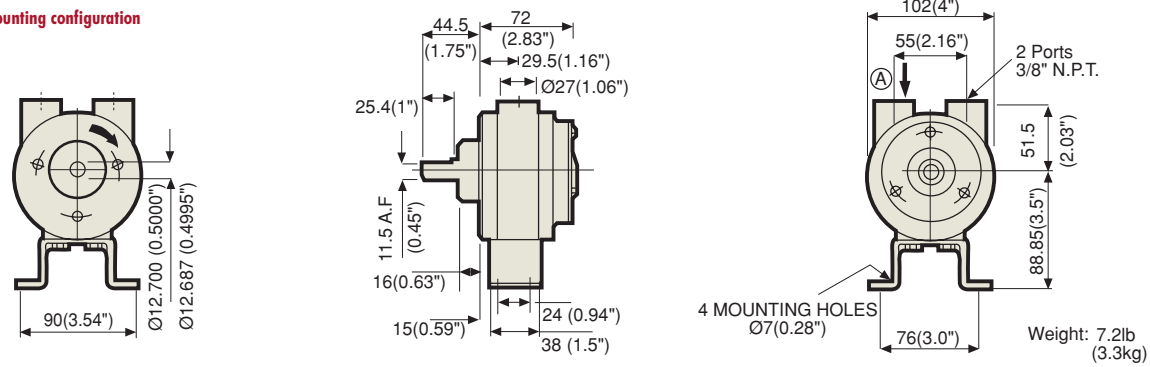

MODEL VA2X Face Mounting configuration

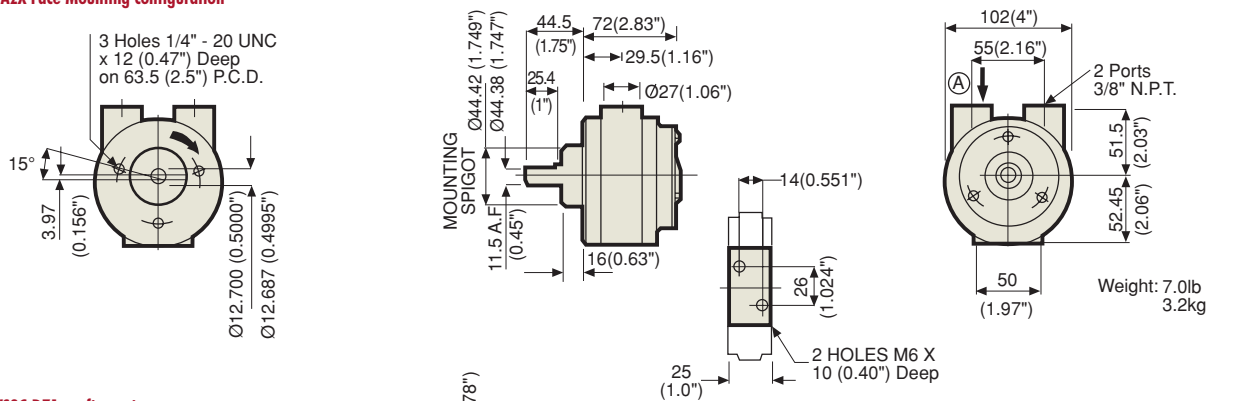

MODEL VS2C D71 configuration

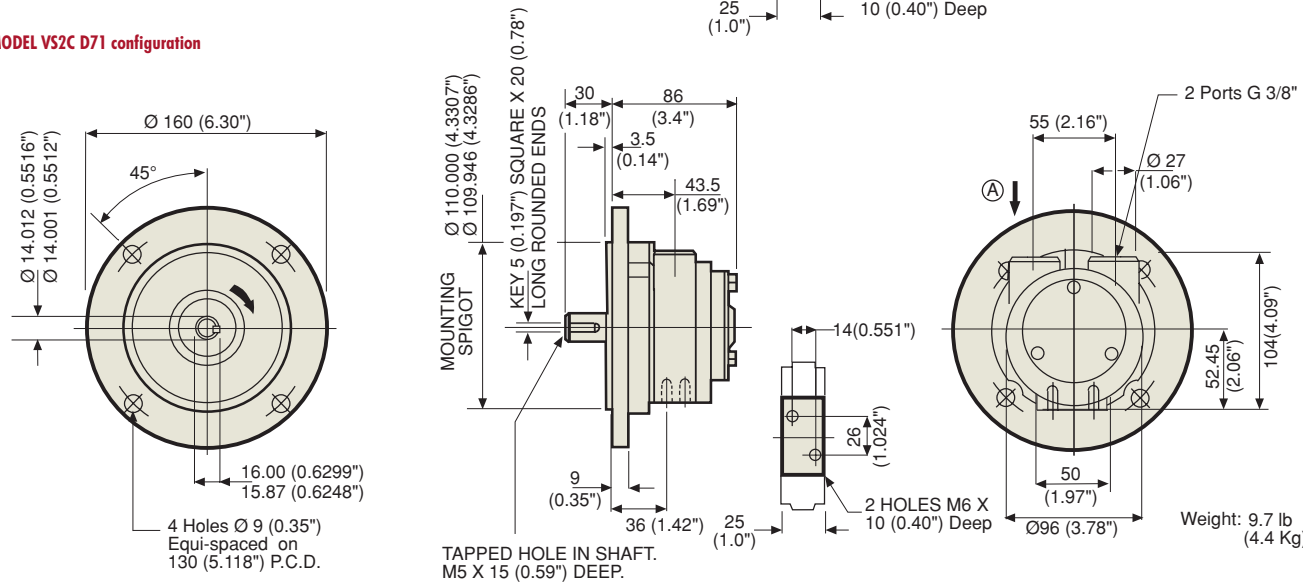

PERFORMANCE V2 | 1.1 HP/0.82KW REVERSIBLE

GRAPH 1 TORQUE - SPEED

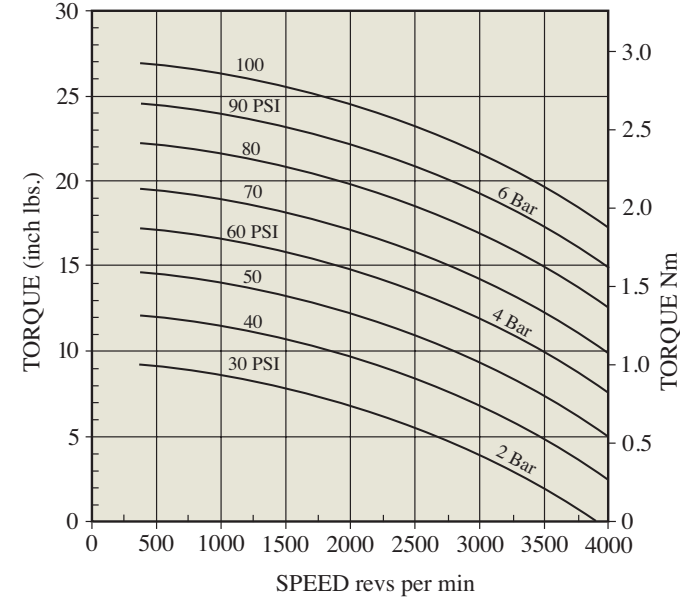

GRAPH 2 STARTING TORQUE - PRESSURE

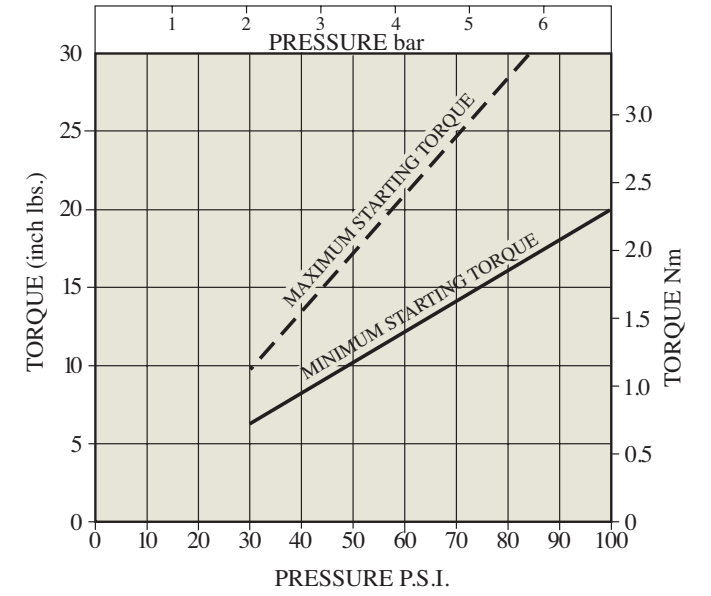

GRAPH 3 POWER - SPEED

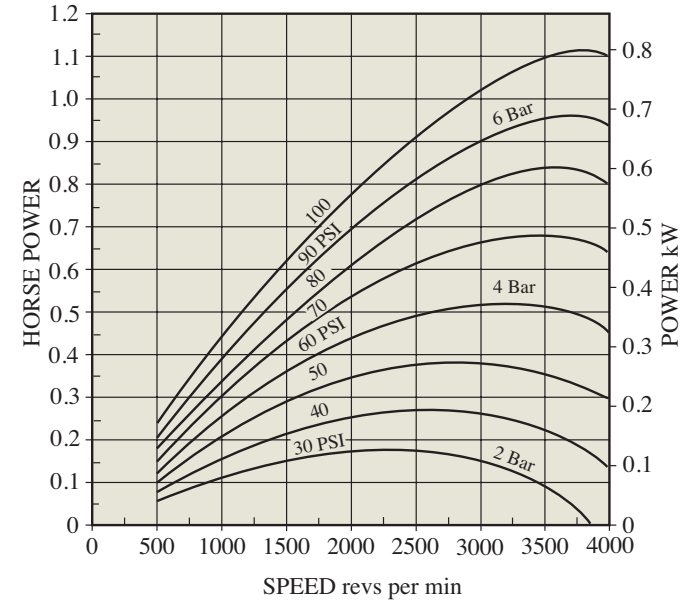

GRAPH 4 CONSUMPTION - SPEED

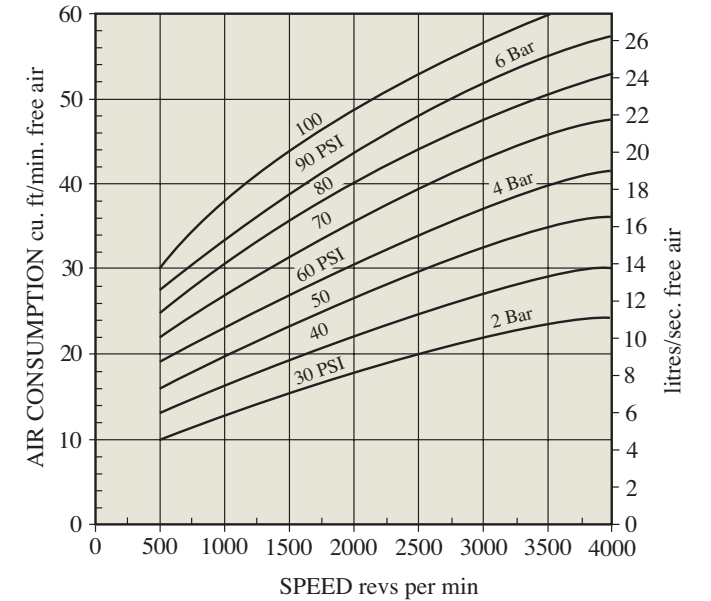

ATTITUDE:

The motor can be operated in all orientations.

AIRLINE FILTRATION AND LUBRICATION:

Use 64 micron filtration or better. Choose a lubricator suitable for the flow required. Prior to start up, inject oil into the inlet port.

LUBRICATOR DROP RATE:

4-5 drops per minute continuous operation.
9-12 drops per minute intermittent operation.

POLAR MOMENT OF INERTIA:

0.47 lb.ins² (0.139 g.m²).

MAXIMUM OVERHUNG FORCE ON SHAFT:

90 lbf (400N) In certain circumstances this may be extended. Consult your GLOBE Distributor. Axial loads should be kept to a minimum.

MAXIMUM TEMPERATURES:

-40° to +176° Fahrenheit. (-20° to +80°C)

DIMENSIONS V4

MODEL VA4C Nema 56C configuration

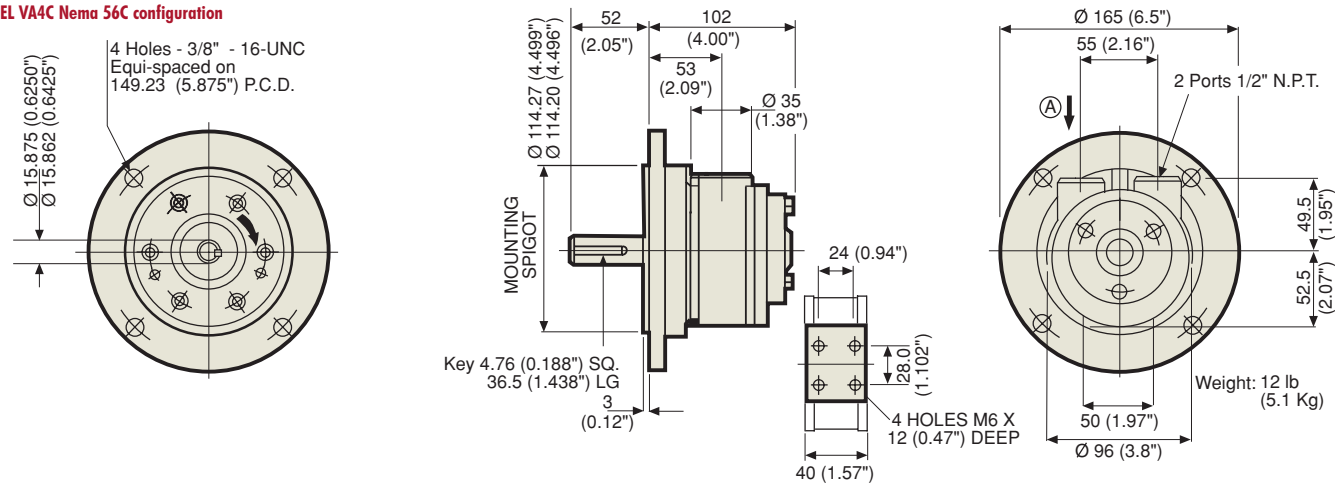

MODEL VA4J Foot Mounting configuration

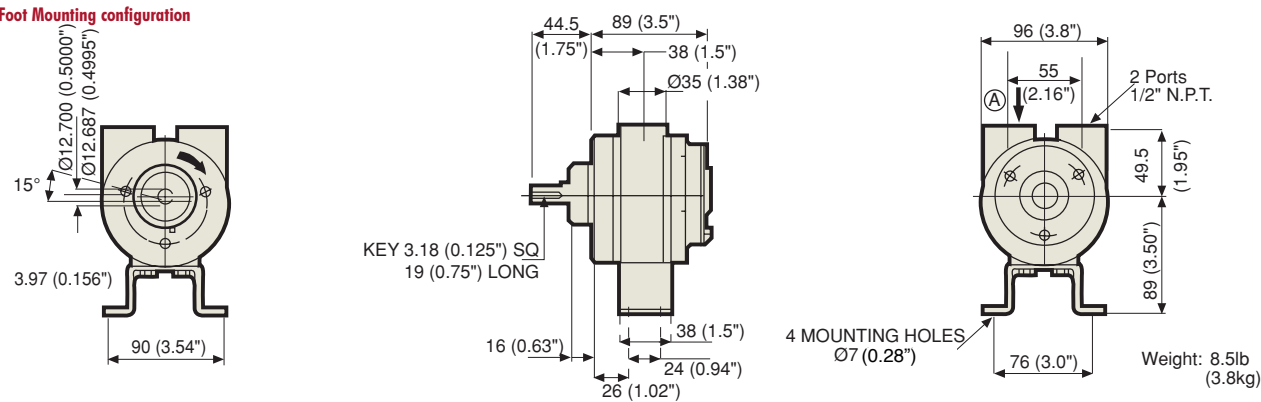

MODEL VA4X Face Mounting configuration

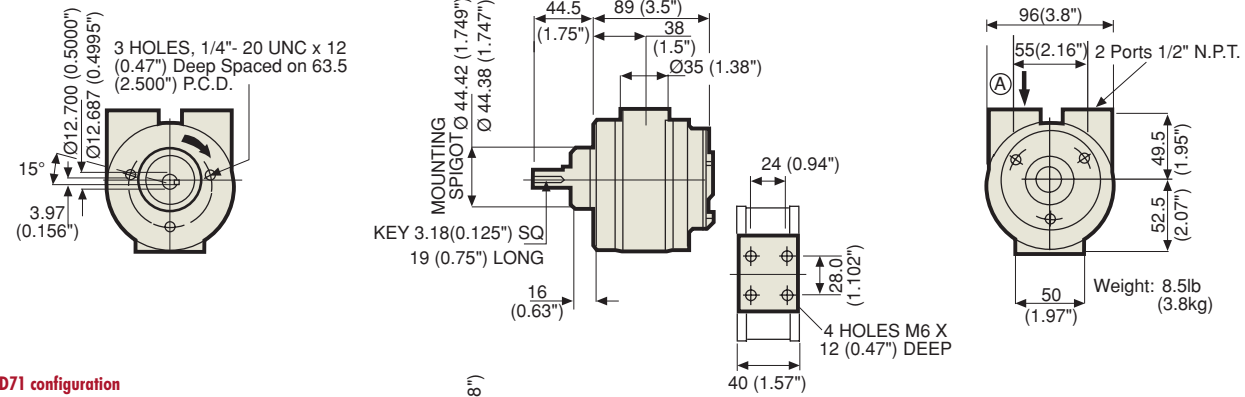

MODEL VS4C D71 configuration

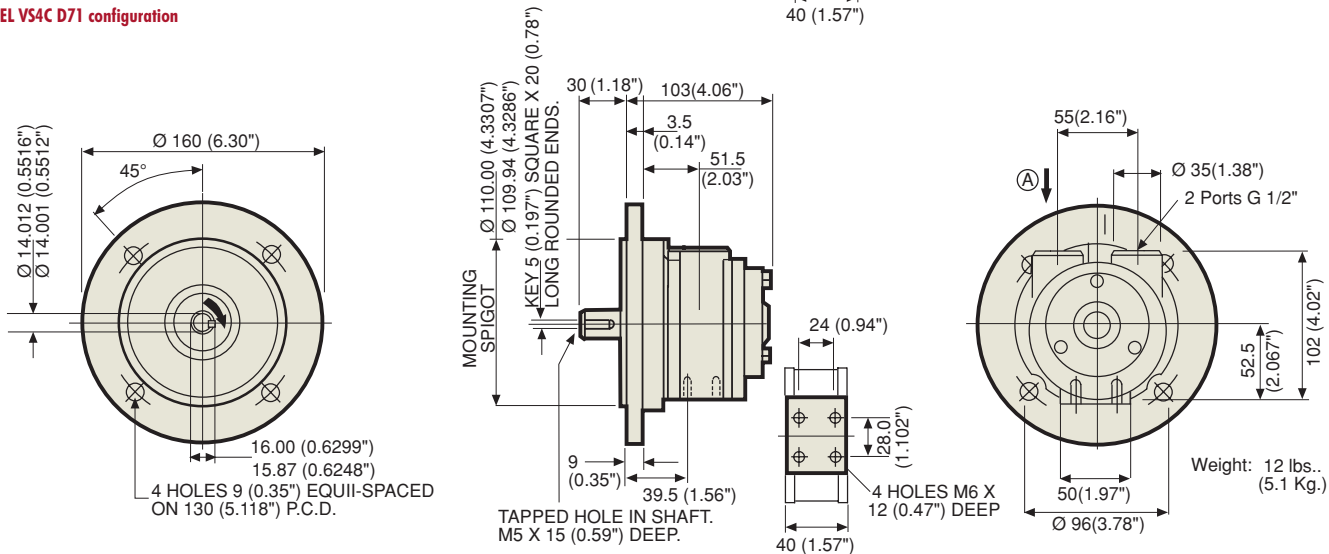

PERFORMANCE V4 | 2.8 HP/2.1 KW REVERSIBLE

GRAPH 1 TORQUE - SPEED

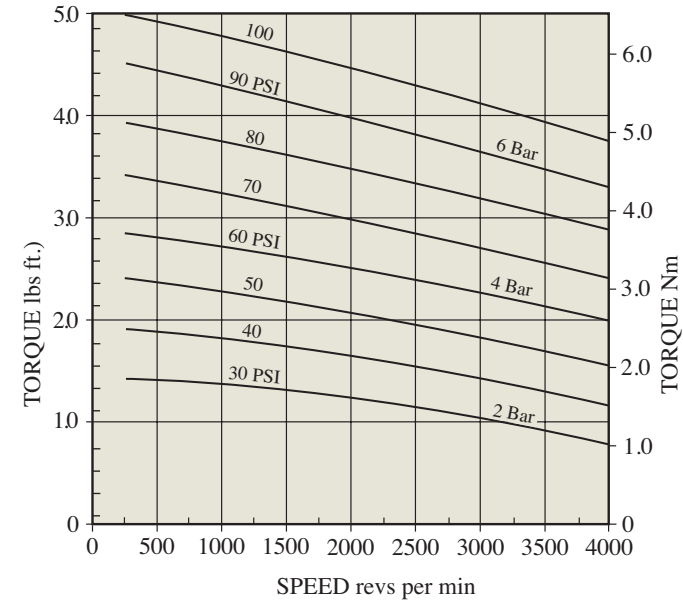

GRAPH 2 STARTING TORQUE - PRESSURE

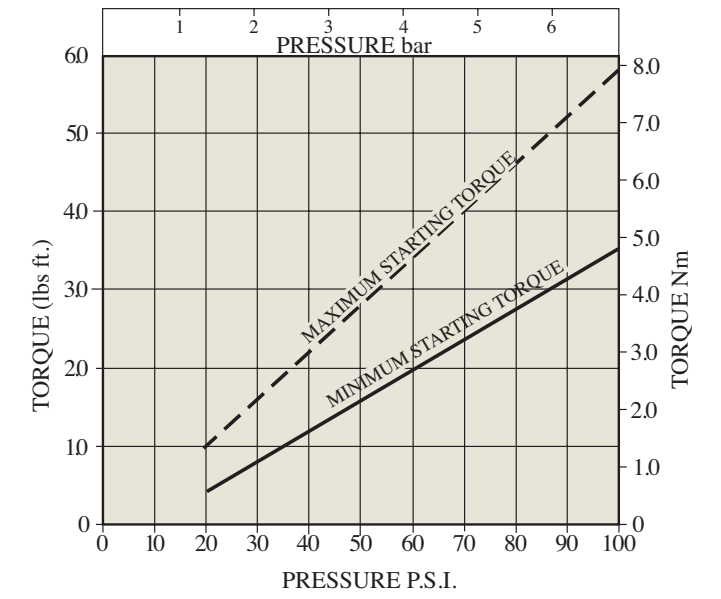

GRAPH 3 POWER - SPEED

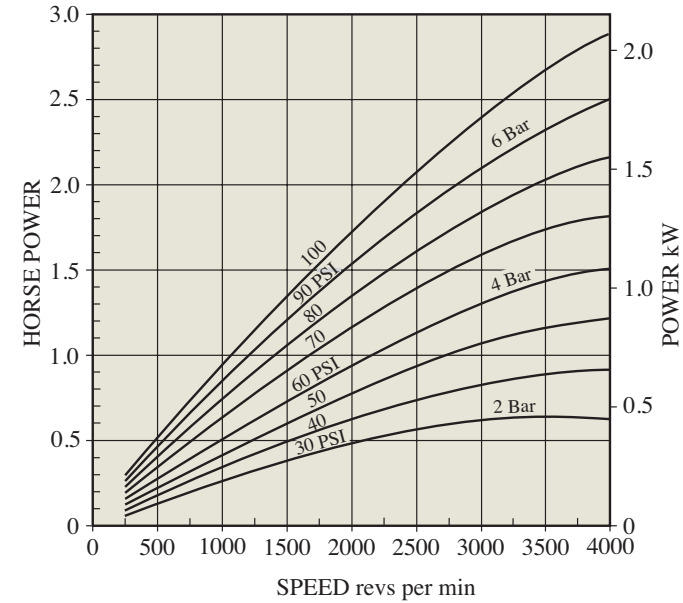

GRAPH 4 CONSUMPTION - SPEED

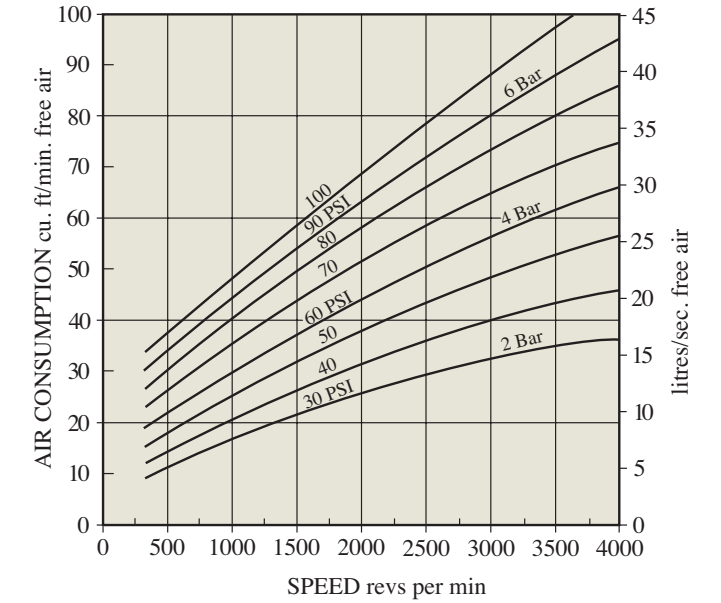

ATTITUDE:

The motor can be operated in all orientations.

AIRLINE FILTRATION AND LUBRICATION:

Use 64 micron filtration or better. Choose a lubricator suitable for the flow required. Prior to start up, inject oil into the inlet port.

LUBRICATOR DROP RATE:

4-5 drops per minute continuous operation.
9-12 drops per minute intermittent operation.

POLAR MOMENT OF INERTIA:

0.77 lb.ins² (0.226 g.m²).

MAXIMUM OVERHUNG FORCE ON SHAFT:

40 lbf (170N) In certain circumstances this may be extended. Consult your GLOBE Distributor. Axial loads should be kept down to a minimum.

MAXIMUM TEMPERATURES:

-40° to +176° Fahrenheit. (-20° to +80°C)

DIMENSIONS V6

MODEL VA6C Nema 56C Configuration

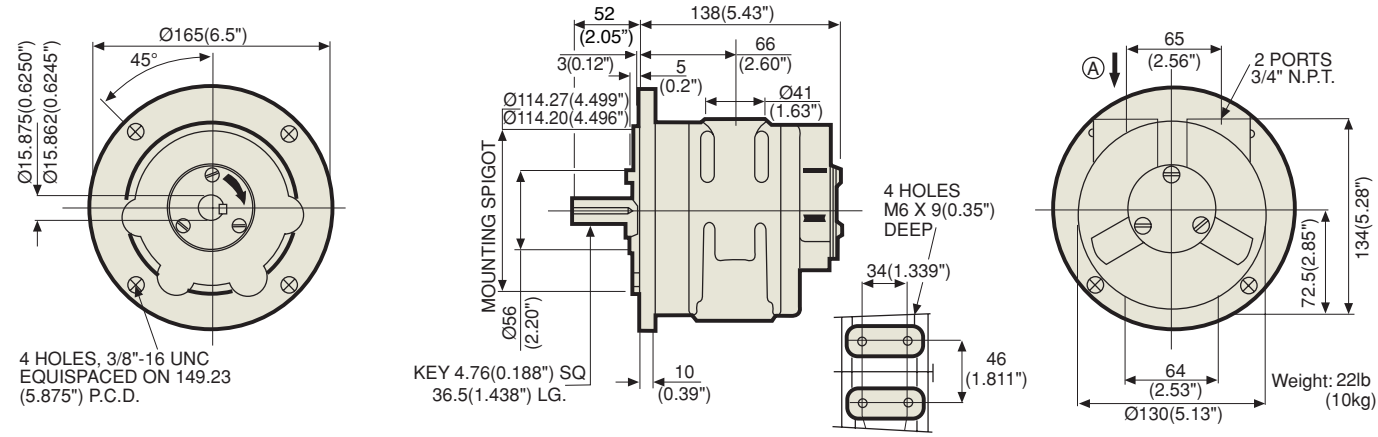

MODEL VA6J Foot Mounting Configuration

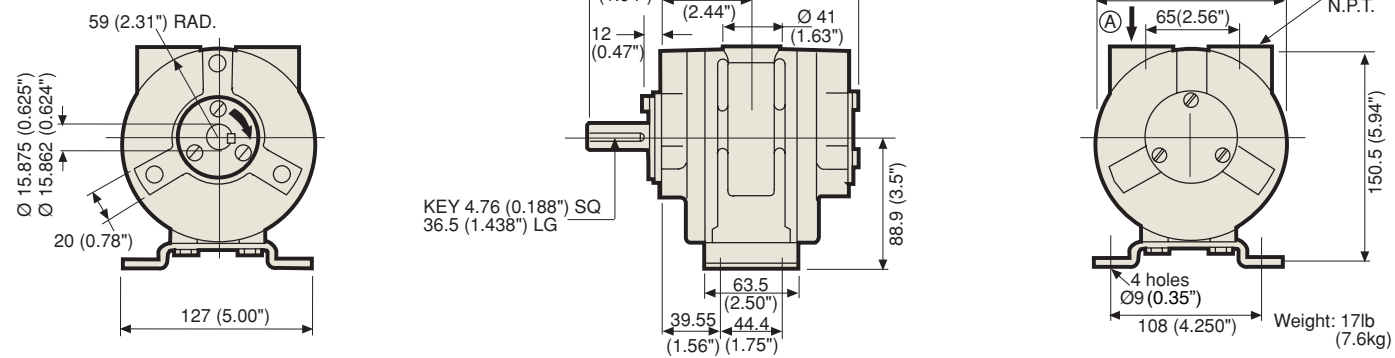

MODEL VA6X Face Mounting Configuration

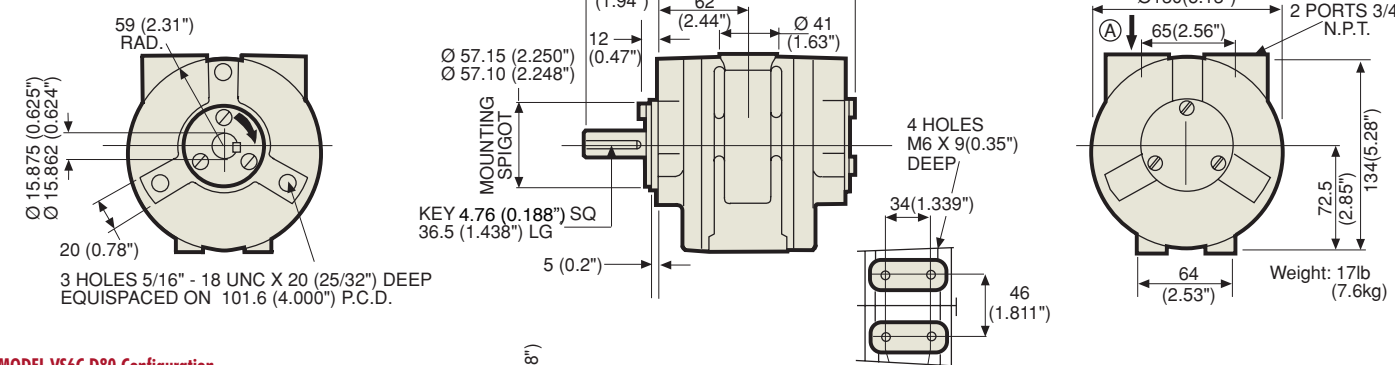

MODEL VS6C D80 Configuration

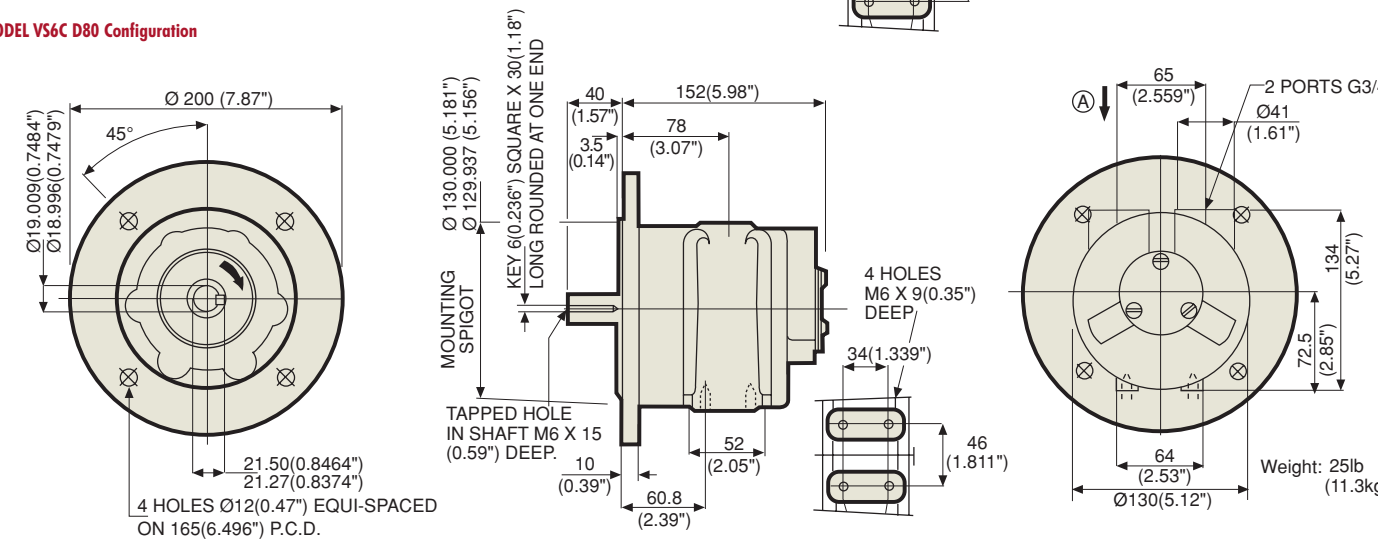

PERFORMANCE V6 | 4.6 HP /3.4 KW REVERSIBLE

GRAPH 1 TORQUE - SPEED

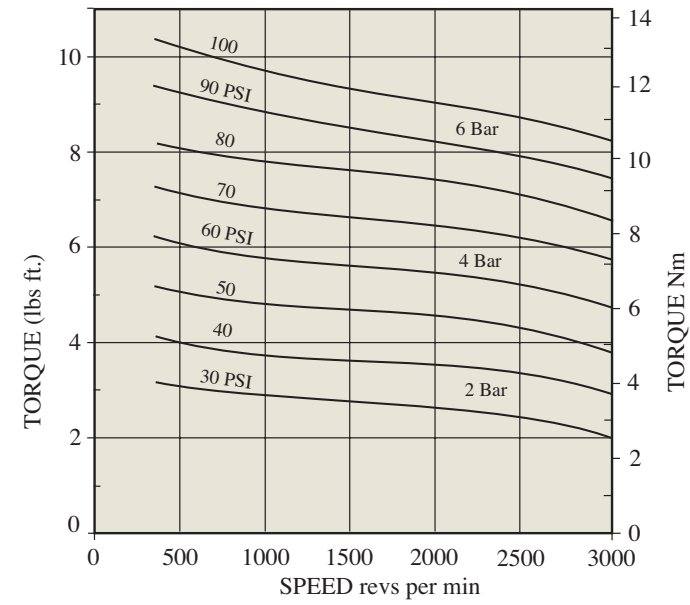

GRAPH 2 STARTING TORQUE - PRESSURE

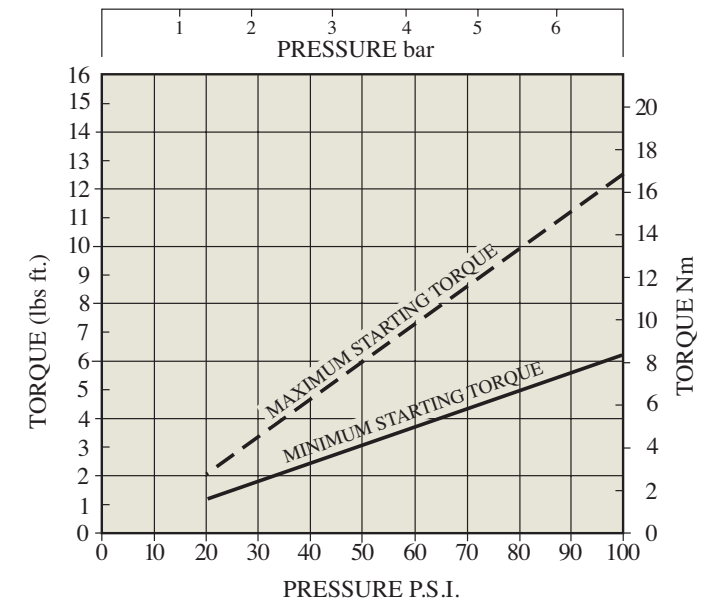

GRAPH 3 POWER - SPEED

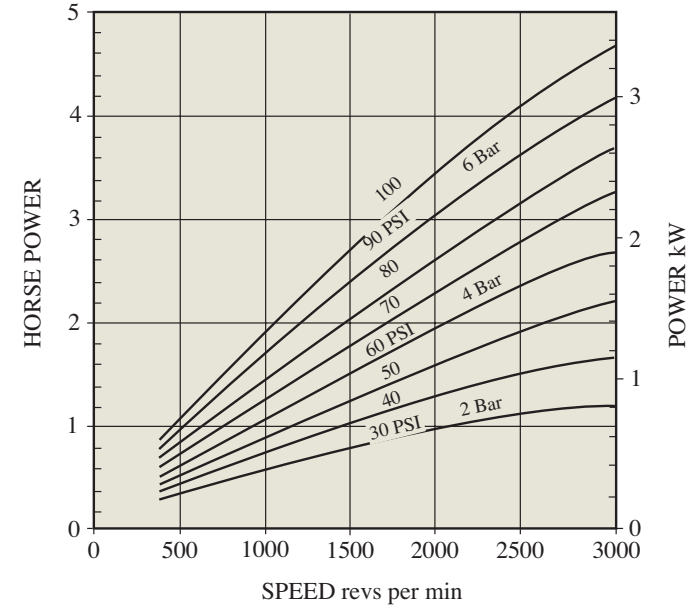

GRAPH 4 CONSUMPTION - SPEED

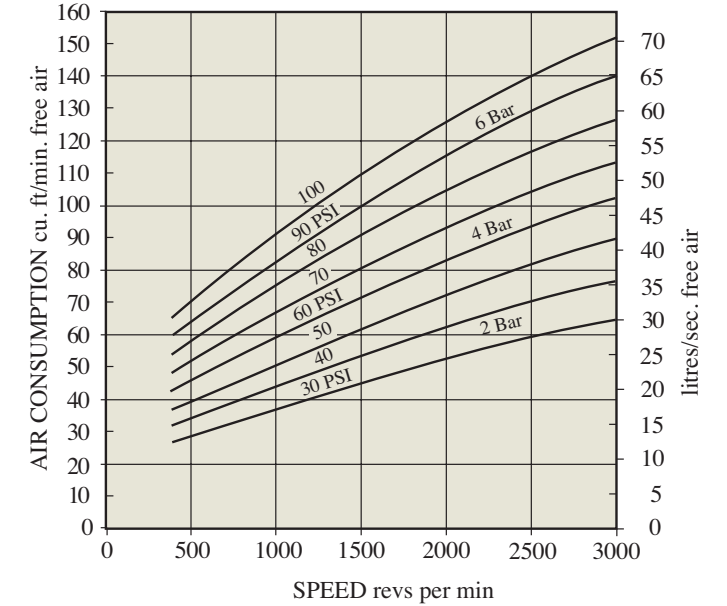

ATTITUDE:

The motor can be operated in all orientations.

AIRLINE FILTRATION AND LUBRICATION:

Use 64 micron filtration or better. Choose a lubricator suitable for the flow required. Prior to start up, inject oil into the inlet port.

LUBRICATOR DROP RATE:

5-6 drops per minute continuous operation.
10-12 drops per minute intermittent operation.

POLAR MOMENT OF INERTIA:

1.56 lb.ins² (0.45 g.m²).

MAXIMUM OVERHUNG FORCE ON SHAFT:

70 lbf (300N) In certain circumstances this may be extended. Consult your GLOBE Distributor. Axial loads should be kept down to a minimum.

MAXIMUM TEMPERATURES:

-40° to +176° Fahrenheit. (-20° to +80° C)

DIMENSIONS V8

MODEL VA8C I45 TC Configuration

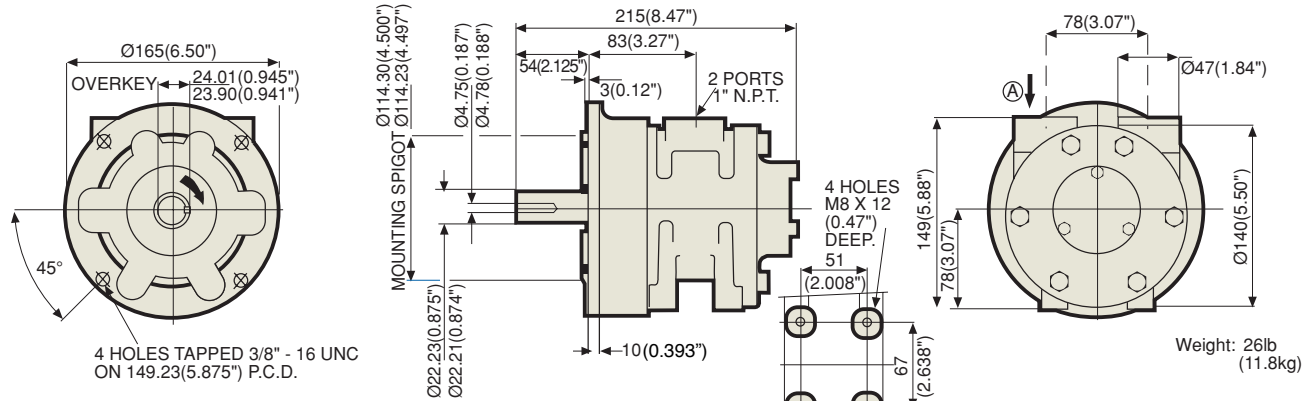

MODEL VA8J Foot Mounting Configuration

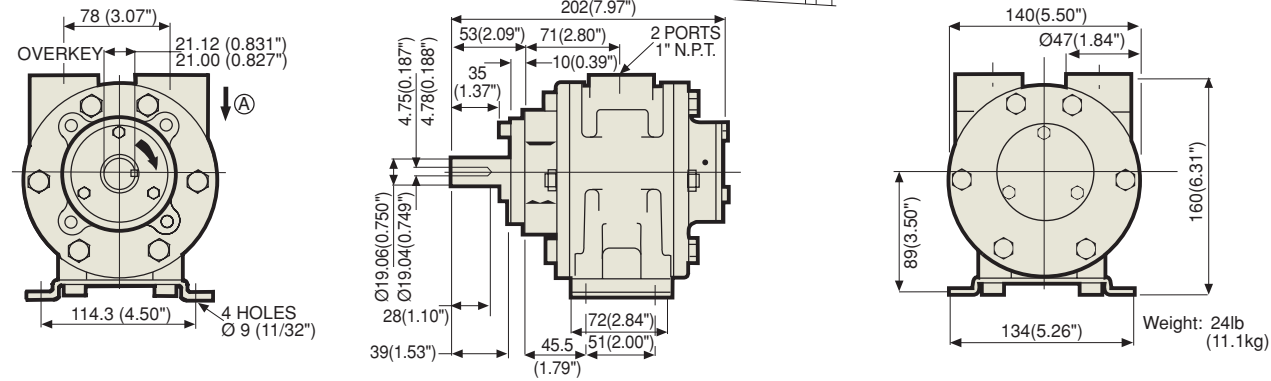

MODEL VA8X Face Mounting Configuration

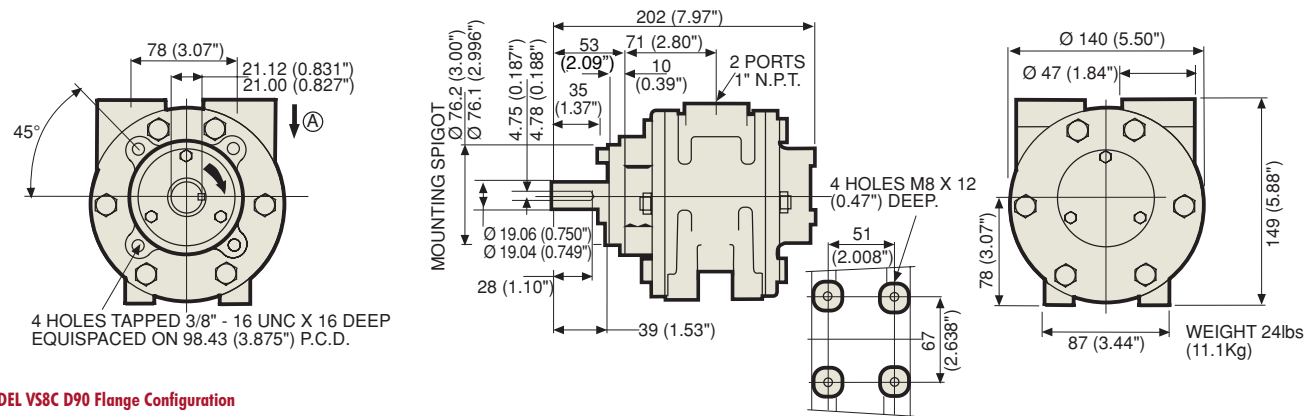

MODEL VS8C D90 Flange Configuration

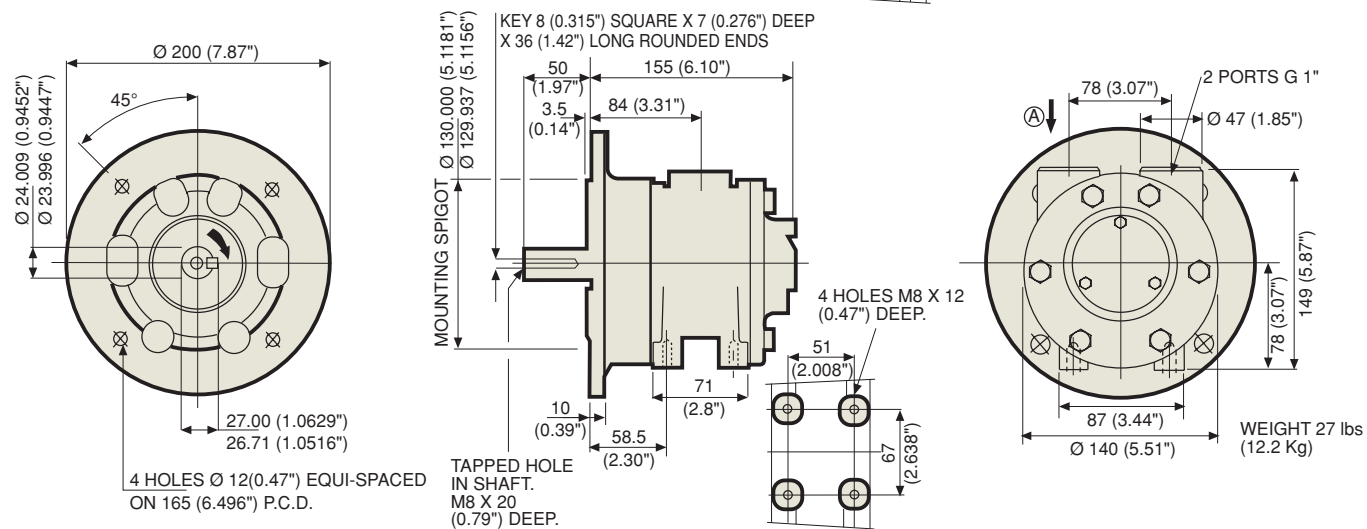

PERFORMANCE V8 | 7.2 HP/5.4 KW REVERSIBLE

GRAPH 1 TORQUE - SPEED

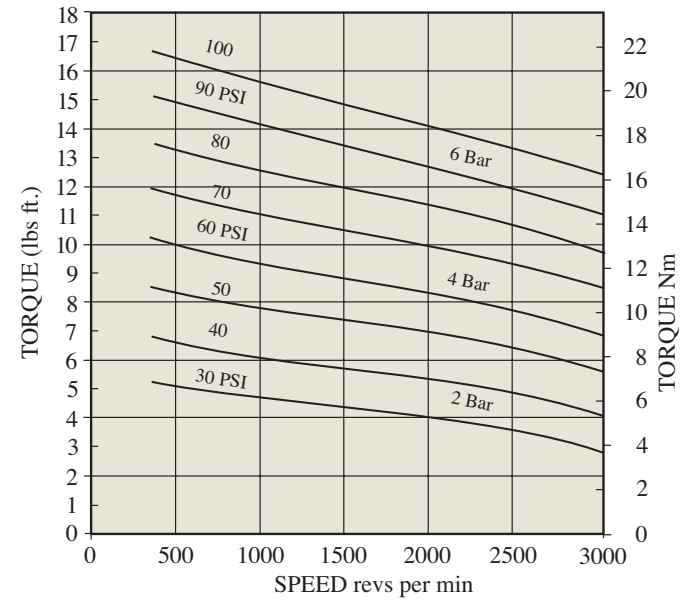

GRAPH 2 STARTING TORQUE - PRESSURE

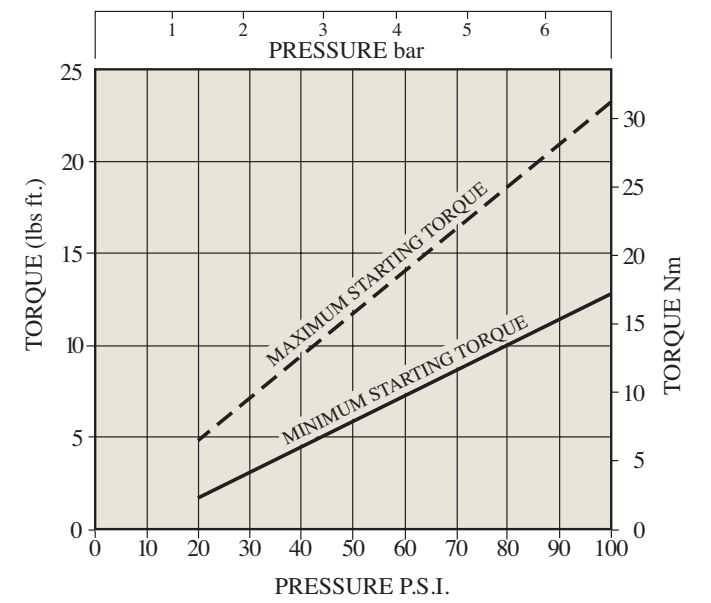

GRAPH 3 POWER - SPEED

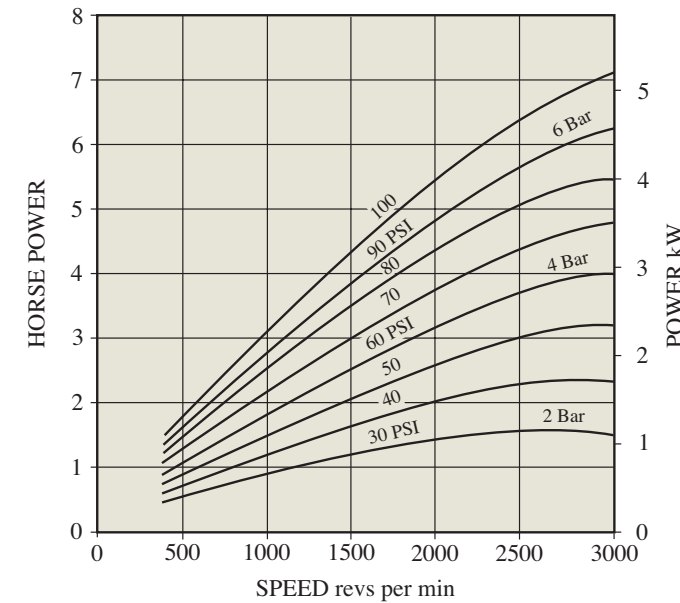

GRAPH 4 CONSUMPTION - SPEED

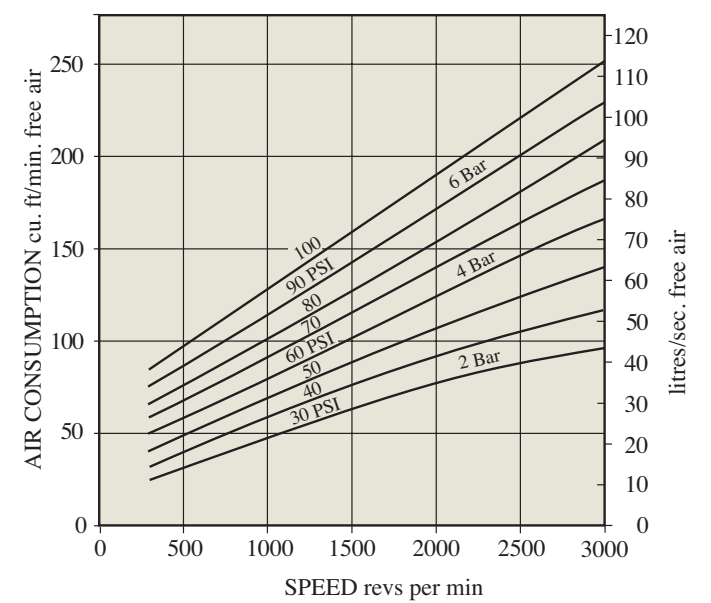

ATTITUDE:

The motor can be operated in all orientations.

AIRLINE FILTRATION AND LUBRICATION:

Use 64 micron filtration or better. Choose a lubricator suitable for the flow required. Prior to start up, inject oil into the inlet port.

LUBRICATOR DROP RATE:

6-7 drops per minute continuous operation.
12-15 drops per minute intermittent operation.

POLAR MOMENT OF INERTIA:

3.5 lb.ins² (1.02 g.m²).

MAXIMUM OVERHUNG FORCE ON SHAFT:

140 lbf (620N) In certain circumstances this may be extended. Consult your GLOBE Distributor. Axial loads should be kept down to a minimum.

MAXIMUM TEMPERATURES:

-40° to +176° Fahrenheit. (-20° to +80° C)

DIMENSIONS V10

MODEL VA10C 145 TC Configuration

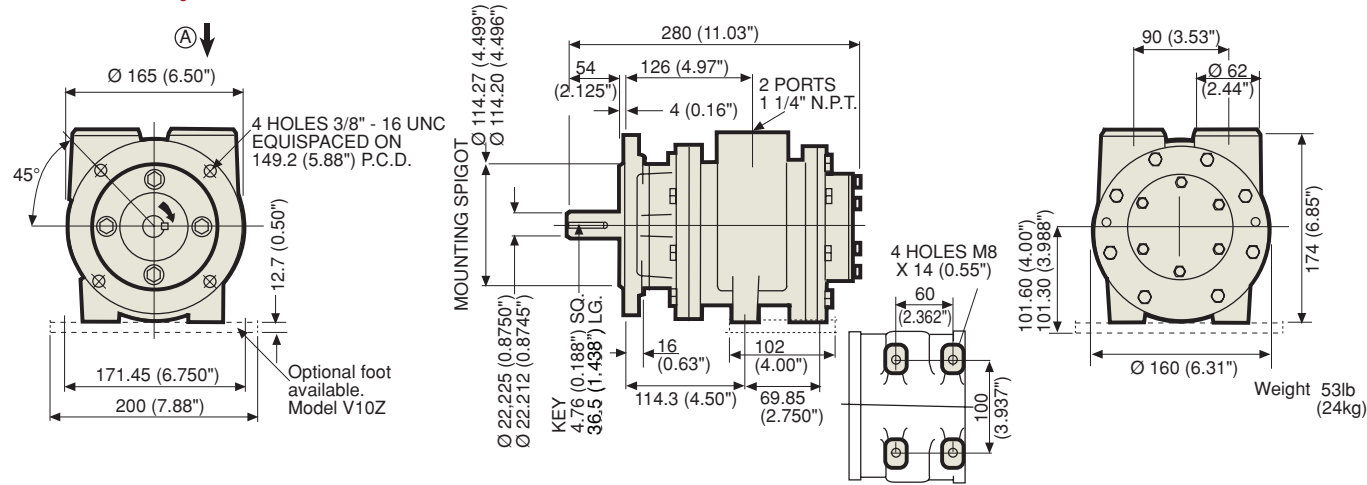

MODEL VA10J Foot Mounting Configuration

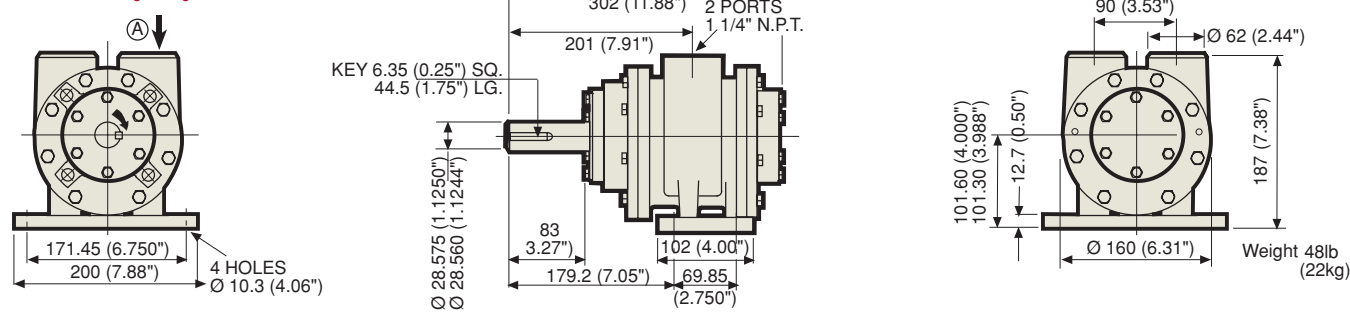

MODEL VA10X Face Mounting Configuration

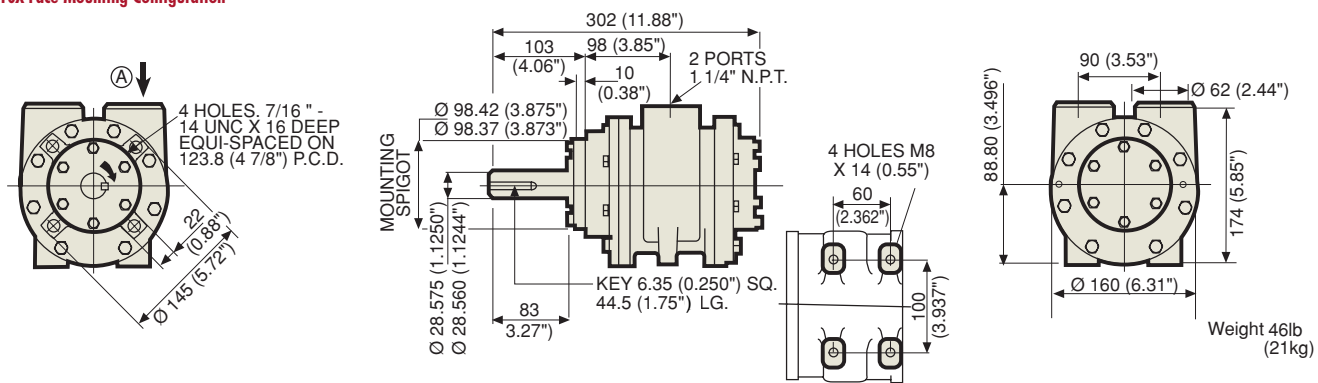

MODEL VS10C D100 Flange Configuration

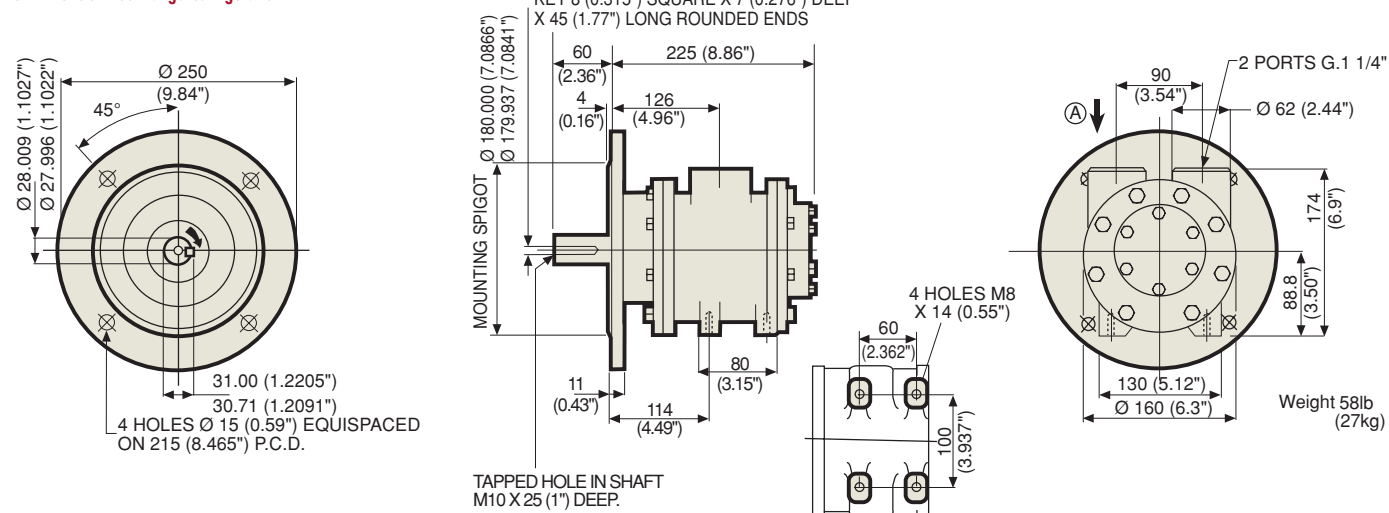

PERFORMANCE V10 | 12.8 HP/9.5 KW REVERSIBLE

GRAPH 1 TORQUE - SPEED

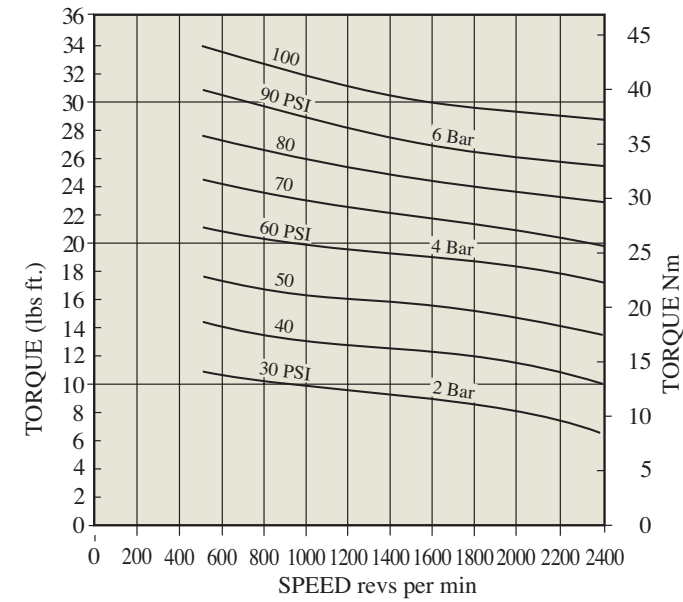

GRAPH 2 STARTING TORQUE - PRESSURE

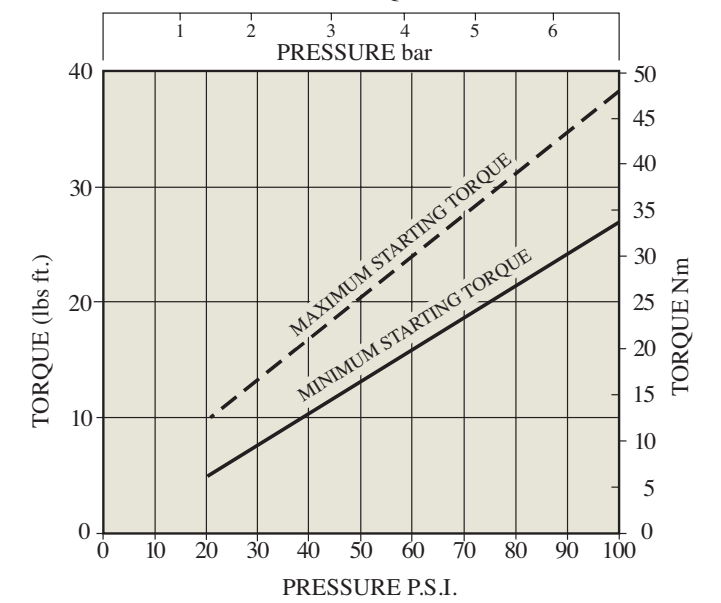

GRAPH 3 POWER - SPEED

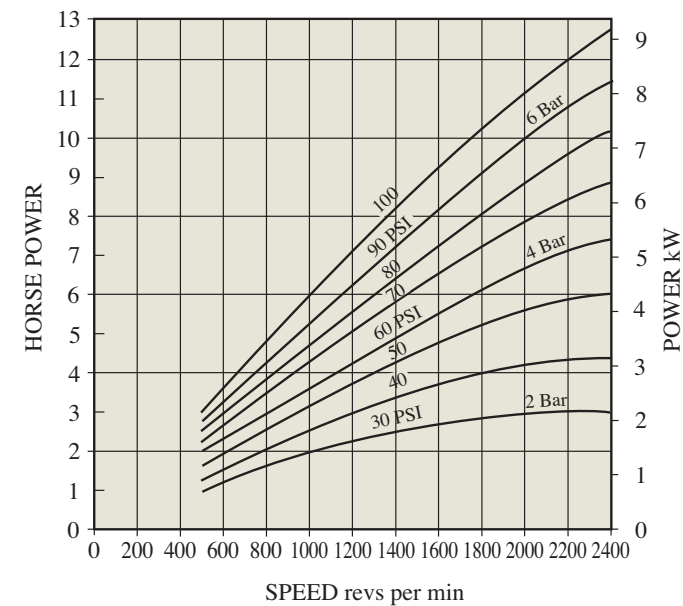

GRAPH 4 CONSUMPTION - SPEED

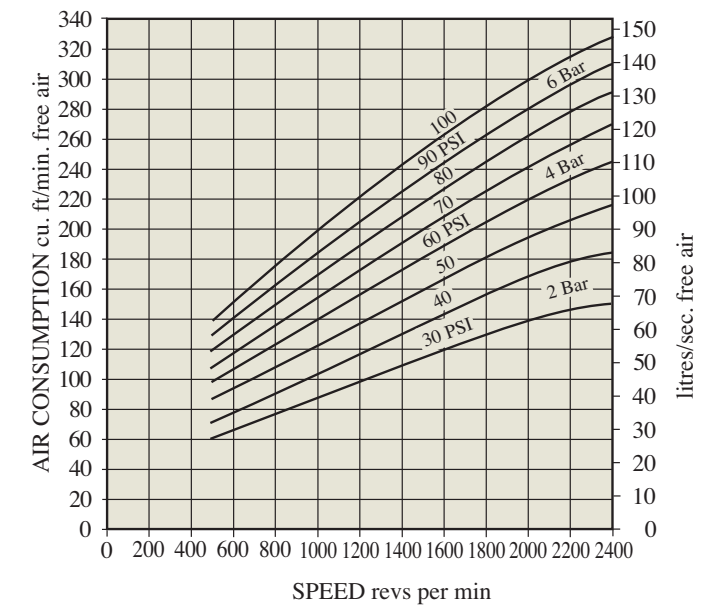

ATTITUDE:

The motor can be operated in all orientations.

AIRLINE FILTRATION AND LUBRICATION:

Use 64 micron filtration or better. Choose a lubricator suitable for the flow required. Prior to start up, inject oil into the inlet port.

LUBRICATOR DROP RATE:

8-10 drops per minute continuous operation.
14-16 drops per minute intermittent operation.

POLAR MOMENT OF INERTIA:

30 lb.in² (8.8 g.m²).

MAXIMUM OVERHUNG FORCE ON SHAFT:

400 lbf (1750N) In certain circumstances this may be extended. Consult your GLOBE Distributor. Axial loads should be kept down to a minimum.

MAXIMUM TEMPERATURES:

-40° to +176° Fahrenheit. (-20° to +80° C)

MODEL VA12C Nema 215T Configuration

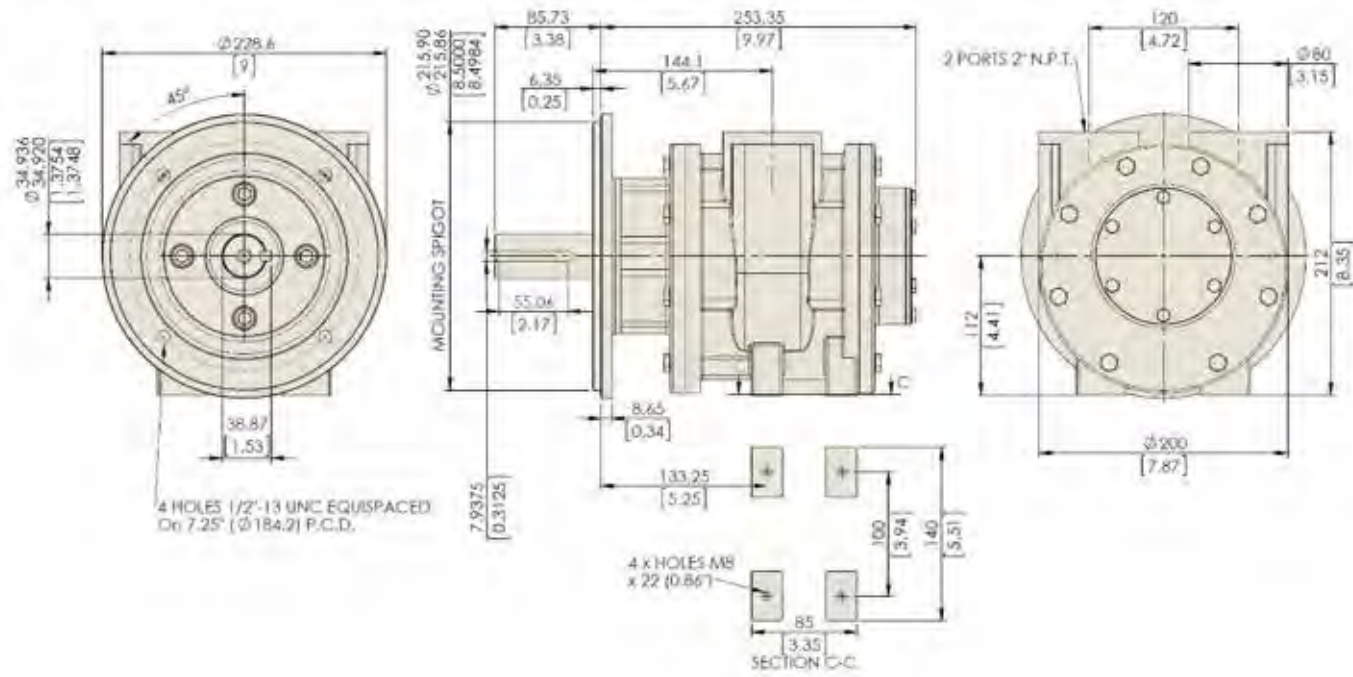

MODEL VS12C D100 Flange Configuration

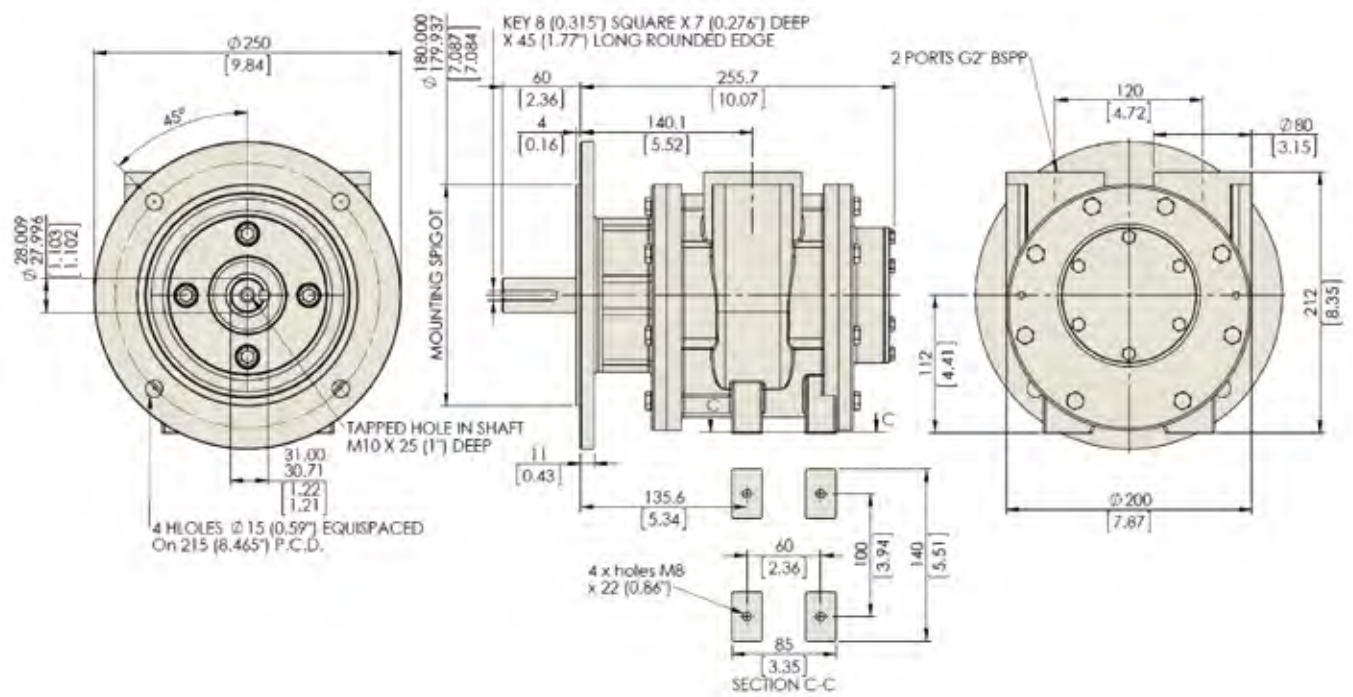

TORQUE - SPEED

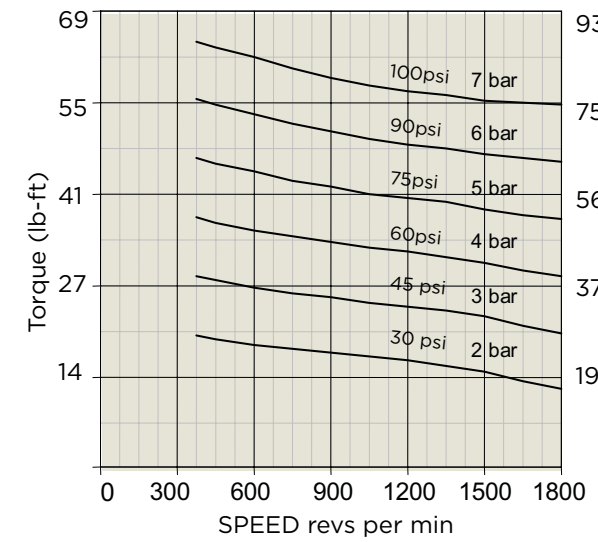

TORQUE - PRESSURE

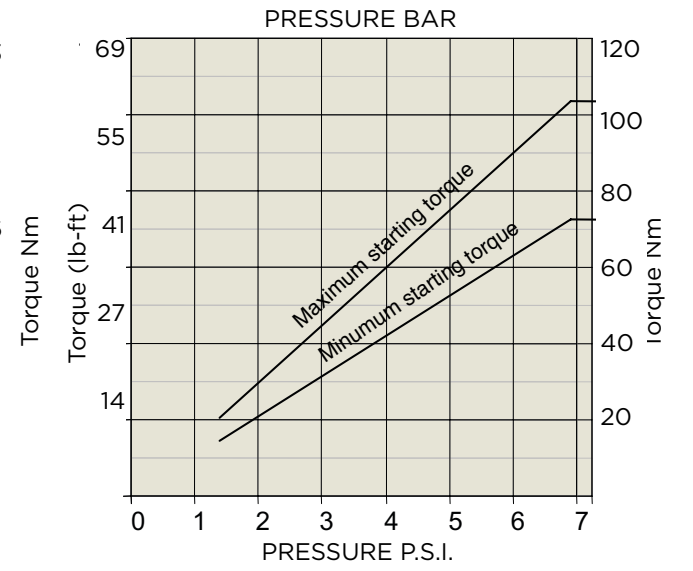

POWER - SPEED

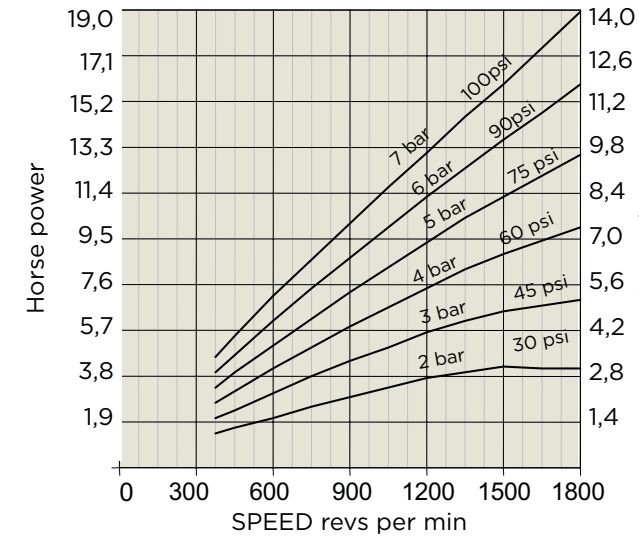

AIR CONSUMPTION - SPEED

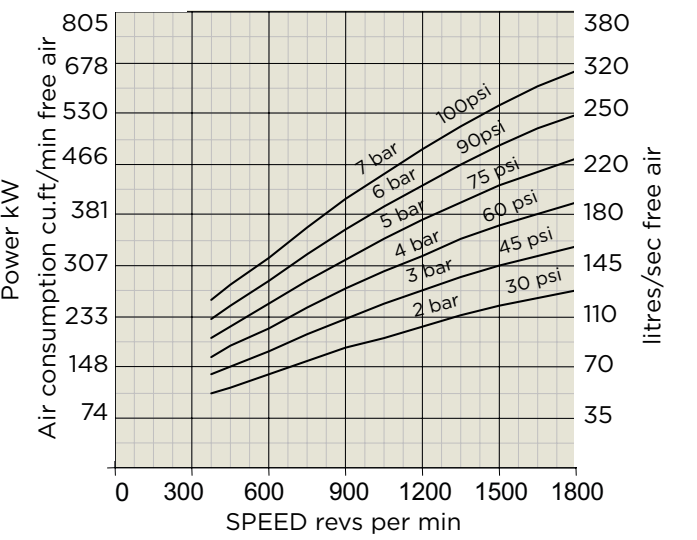

ATTITUDE:

The motor can be operated in all orientations.

AIRLINE FILTRATION AND LUBRICATION:

Use 64 micron filtration or better. Choose a lubricator suitable for the flow required. Prior to start up, inject oil into the inlet port.

LUBRICATOR DROP RATE:

12-14 drops per minute continuous operation.
18-20 drops per minute intermittent operation.

POLAR MOMENT OF INERTIA:

30 lb.in² (8.8 g.m²).

MAXIMUM OVERHUNG FORCE ON SHAFT:

400 lbf (1750N) In certain circumstances this may be extended. Consult your GLOBE Distributor. Axial loads should be kept down to a minimum.

MAXIMUM TEMPERATURES:

-40° to +176° Fahrenheit. (-20° to +80°C)

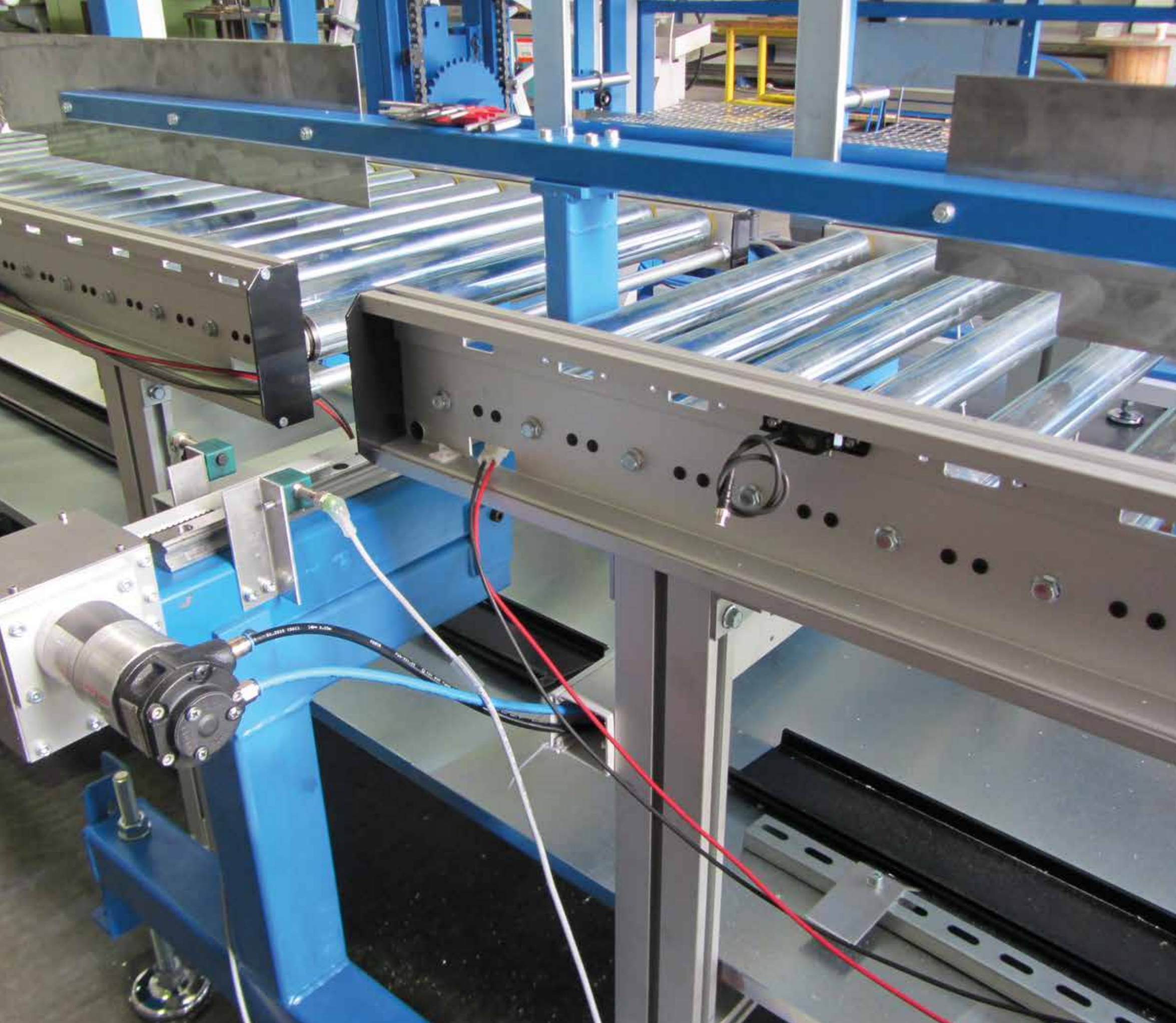

NON LUBRICATED VANE AIR MOTORS

ADVANTAGES

GLOBE Airmotors BV has a special range of air motors that do not require lubrication. The advantages of these motors are:

- No lubricator necessary – save on installation costs
- No inspection of the lubricator oil level is necessary – save on annual running costs
- No oil-contaminated air from the exhaust – protects products and workforce
- Same standard interfaces as the regular GLOBE vane air motors.

All the GLOBE vane air motors can run without lubrication under certain operation conditions. For dry running blades, a filtration to a minimum of 25 microns is recommended.

The maximum air pressure must not exceed 6 bar and the motor speed must not exceed the figures stated in the graphs belonging to the non lubricated motors. The maximum motor speed must never be exceeded when the motor is running off load. As prevention a flow restriction should be fitted on the outlet when the load can vary greatly.

The vanes in non lubricated vane air motors have a shorter life expectancy compared to the standard versions. Maximum continuous speed is 25% less compared to the standard versions. Please consult GLOBE when using a non lubricated vane air motor.

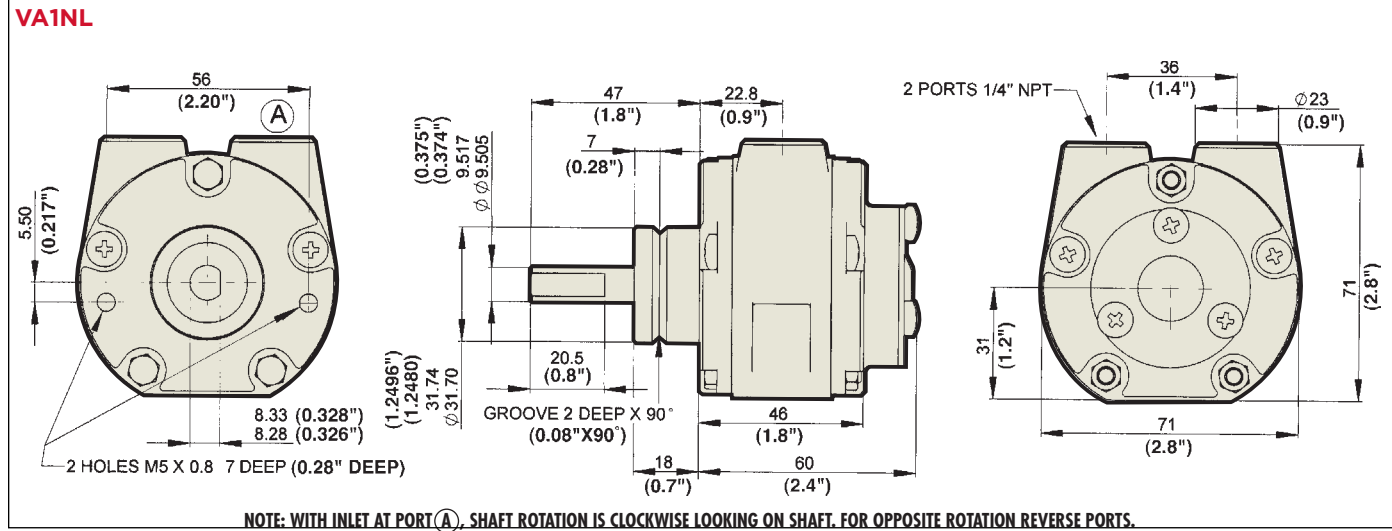

TORQUE - SPEED

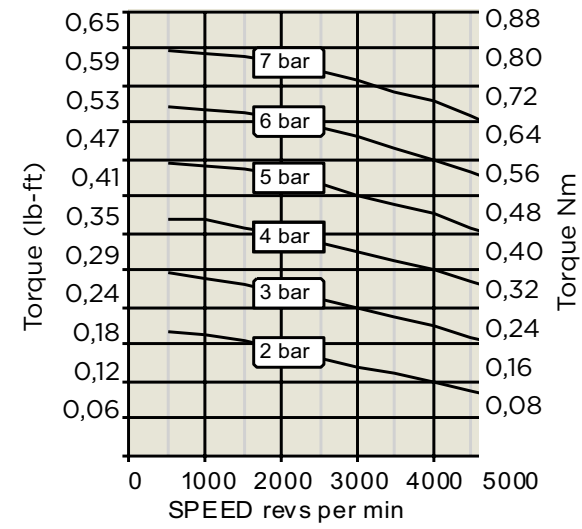

TORQUE - PRESSURE

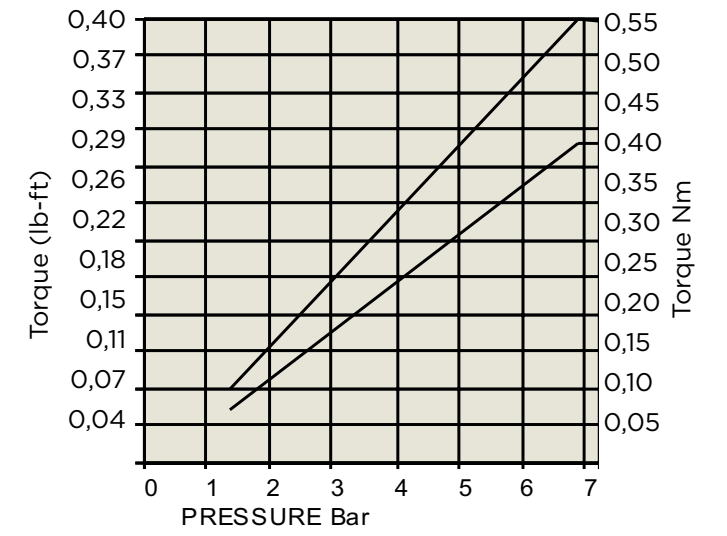

POWER - SPEED

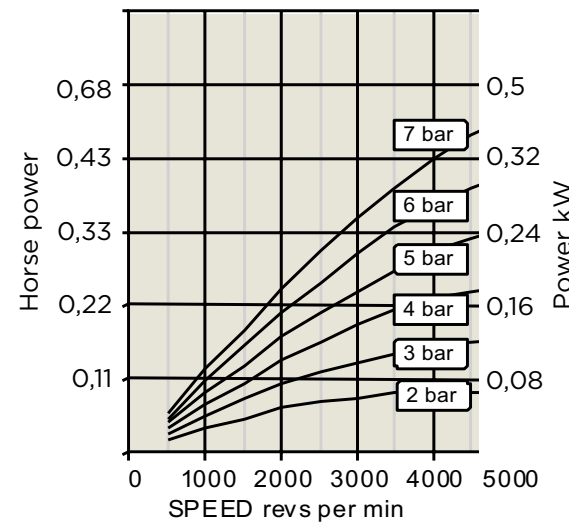

AIR CONSUMPTION - SPEED

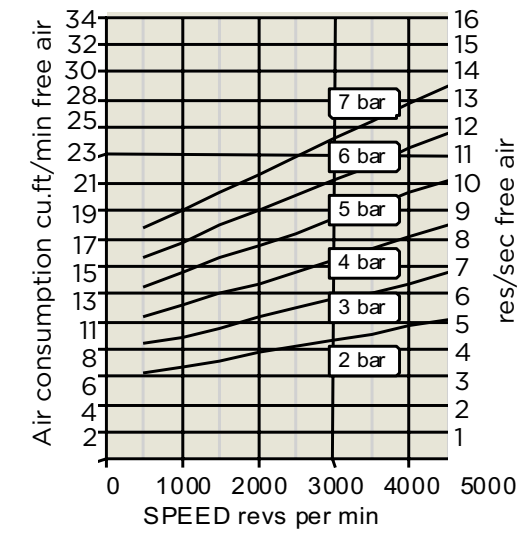

Muffler supplied with motor.

Motor is reversible.

ATTITUDE

The motor can be operated in all positions.

MAXIMUM TEMPERATURE

-20°C to +60°C

(-4°F to +140°F).

AIRLINE FILTRATION

Use 64 micron filtration or better.

MAX. OVERHUNG FORCE ON MOTOR SHAFT

18 N (4.0 lbf.).

Axial loads should be kept to a minimum.

MAXIMUM SPEED 4500 RPM

When operating above 50% of the maximum speed please consult your supplier.

DIMENSIONS V2-NL

MODEL VA2C Nema 56C configuration

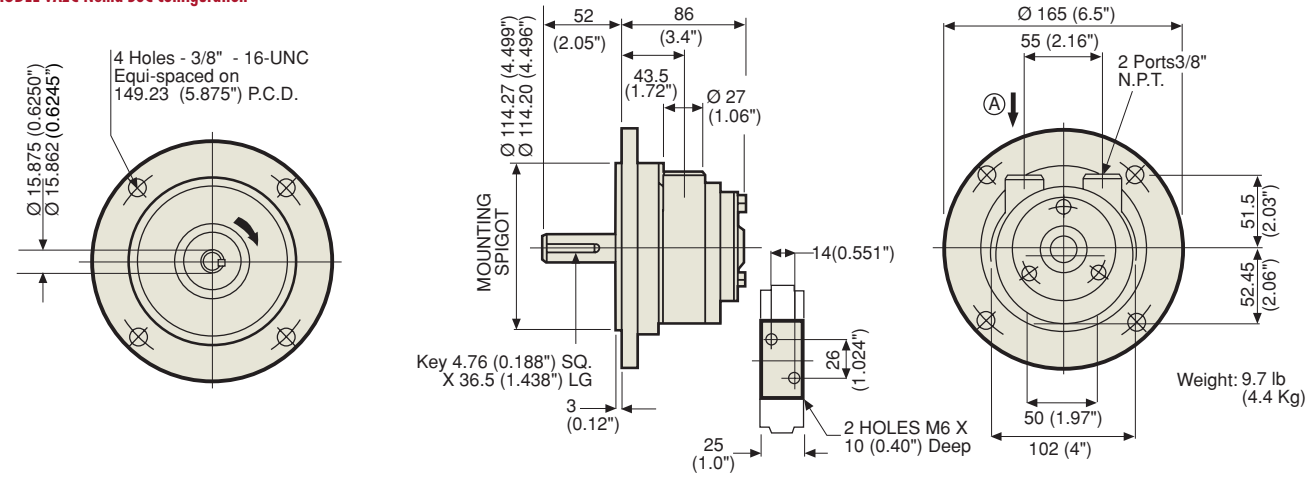

MODEL VA2J Foot Mounting configuration

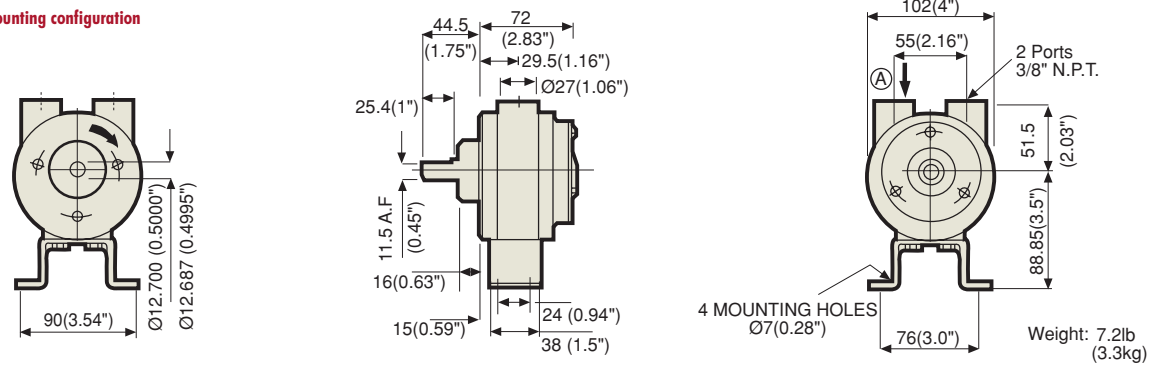

MODEL VA2X Face Mounting configuration

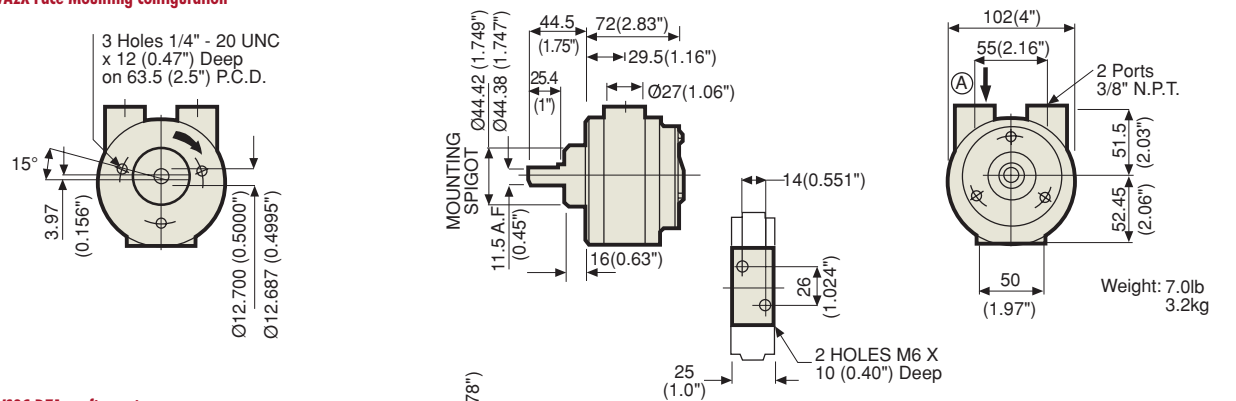

MODEL VS2C D71 configuration

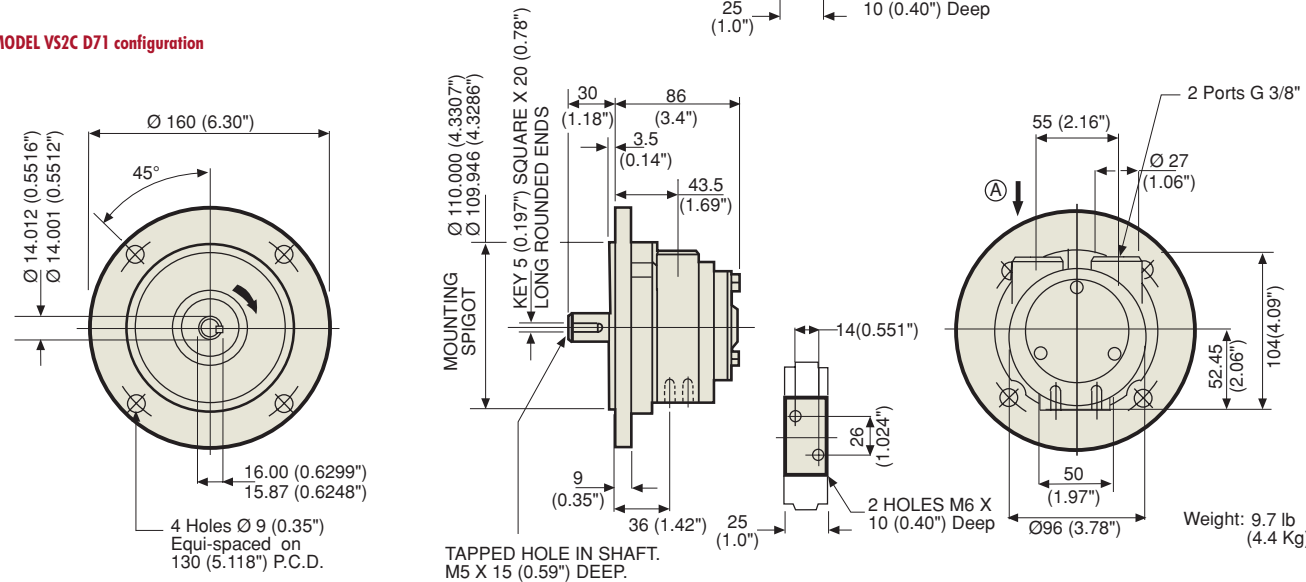

TORQUE - SPEED

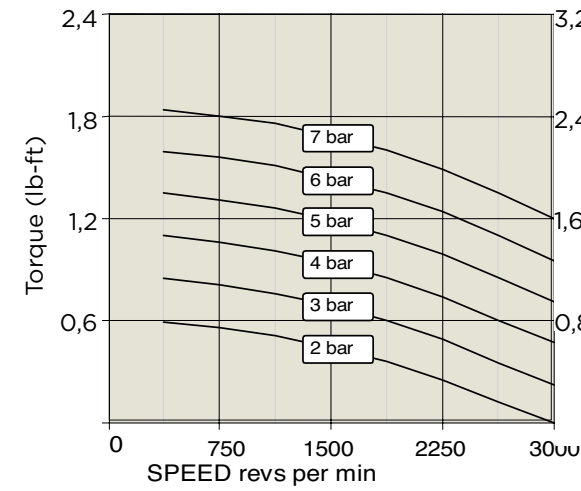

TORQUE - PRESSURE

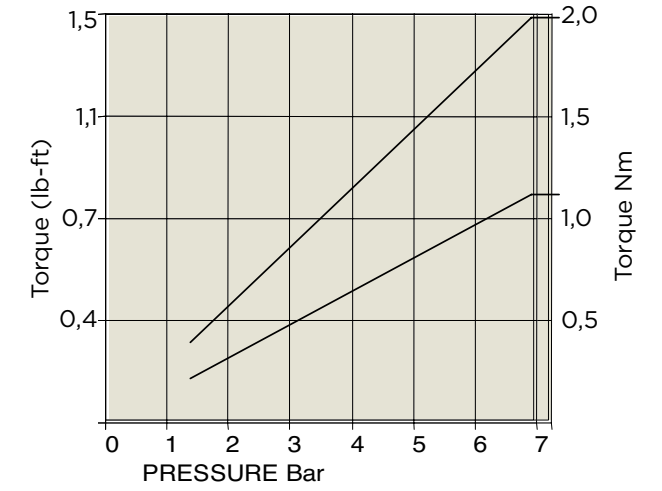

POWER - SPEED

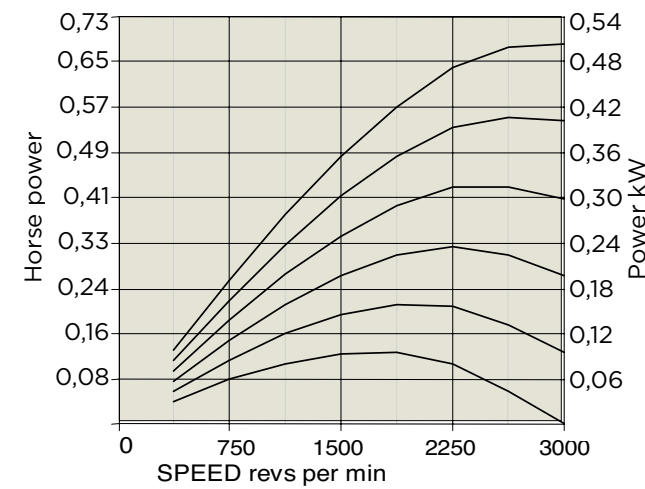

AIR CONSUMPTION - SPEED

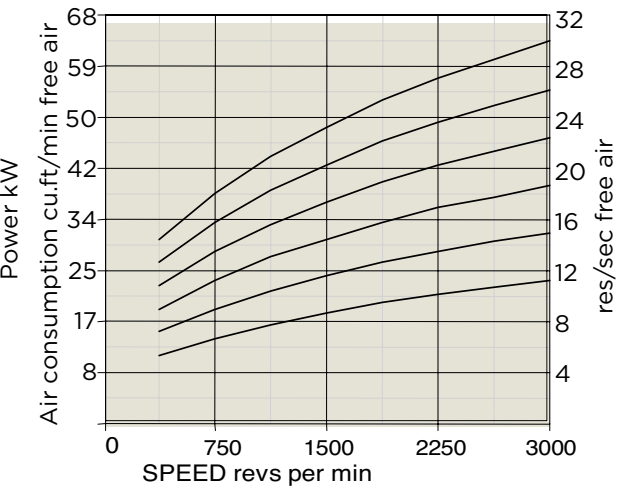

Muffler supplied with motor.

Motor is reversible.

ATTITUDE

The motor can be operated in all positions.

MAXIMUM TEMPERATURE

-20°C to +60°C

(-4°F to +140°F).

AIRLINE FILTRATION

Use 64 micron filtration or better.

MAXIMUM SPEED 3000 RPM

When operating above 50% of the maximum speed please consult your supplier.

DIMENSIONS V4-NL

MODEL VA4C Nema 56C configuration

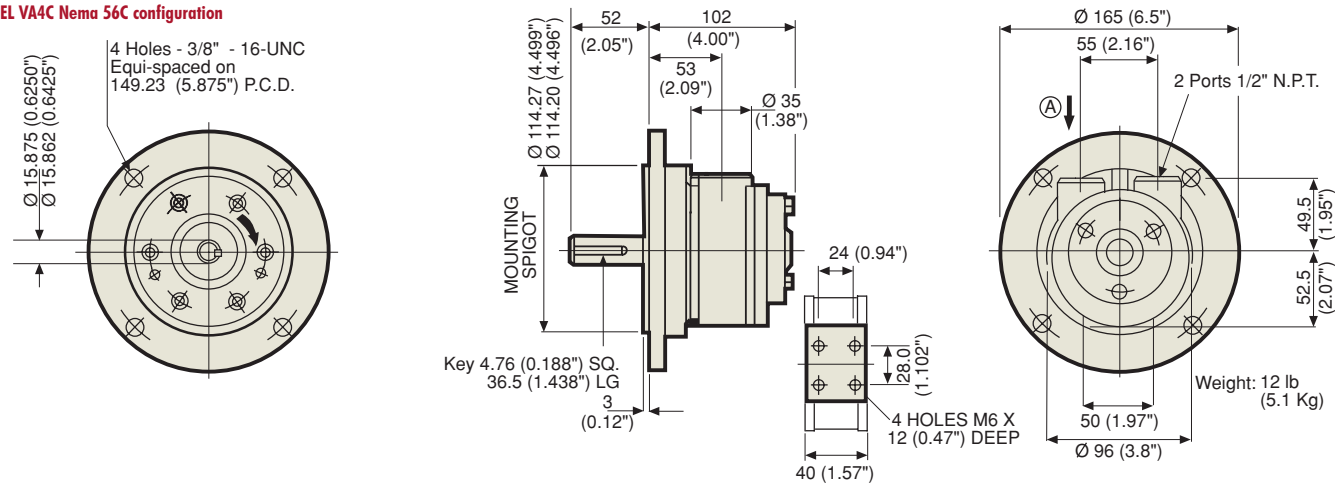

MODEL VA4J Foot Mounting configuration

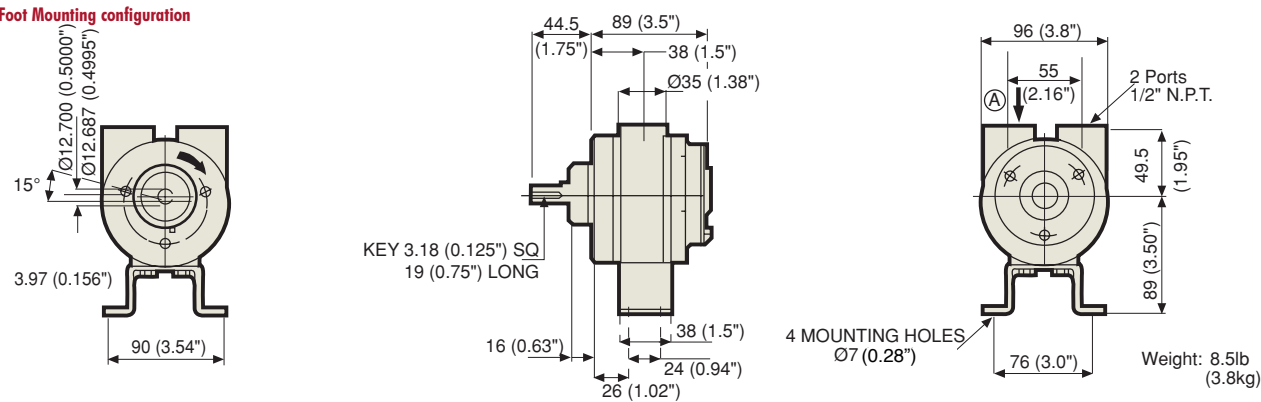

MODEL VA4X Face Mounting configuration

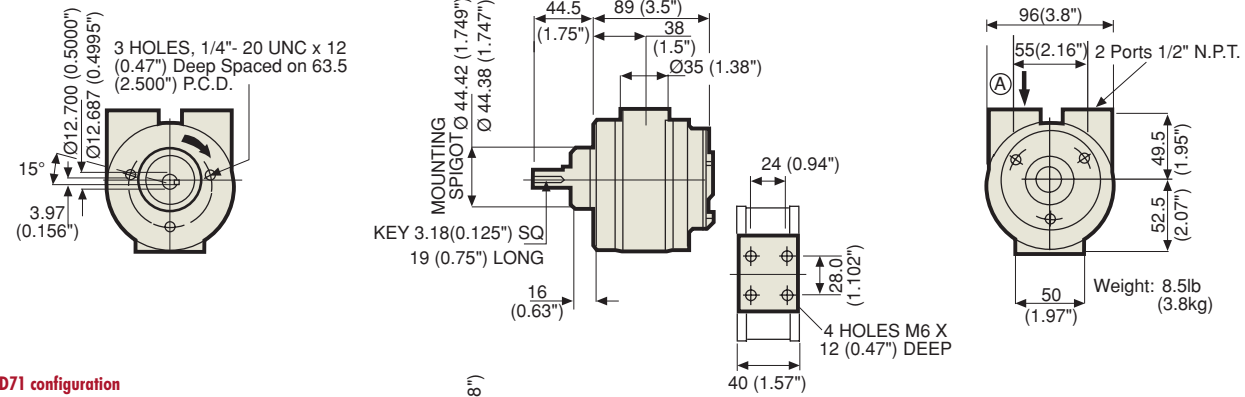

MODEL VS4C D71 configuration

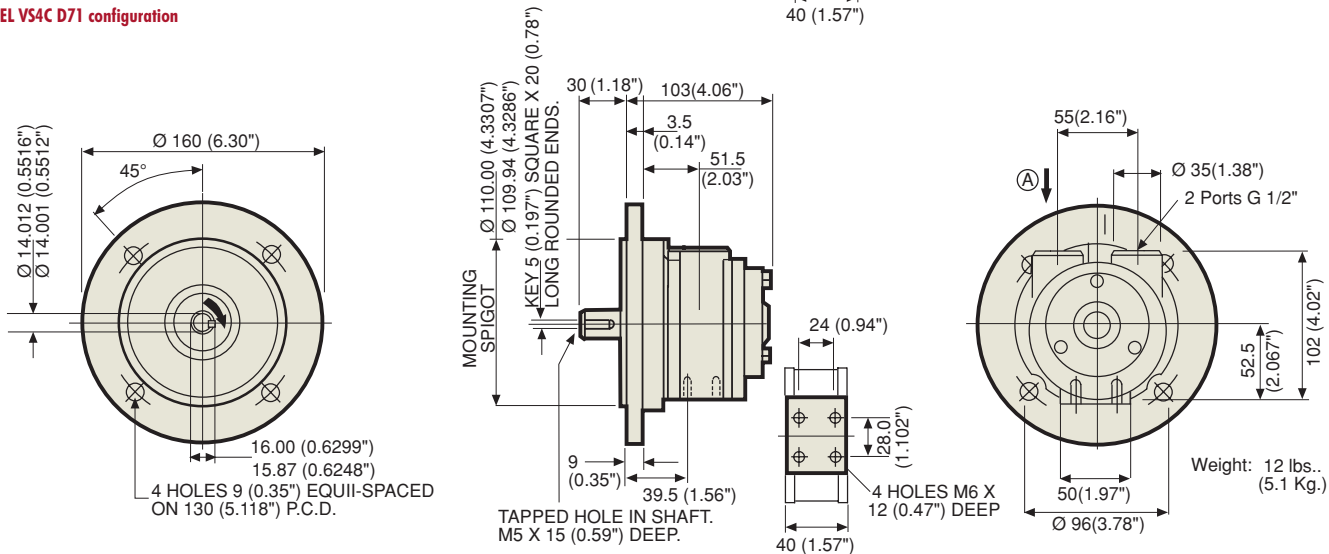

TORQUE - SPEED

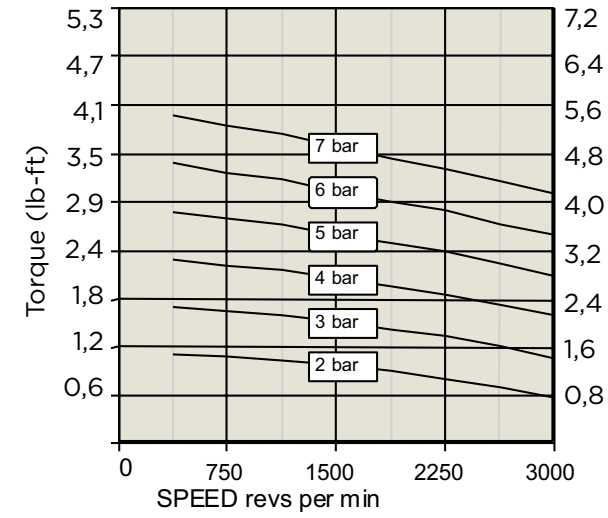

TORQUE - PRESSURE

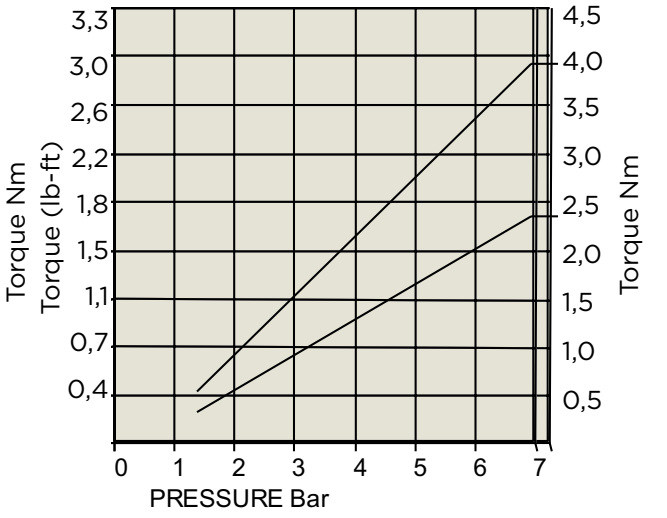

POWER - SPEED

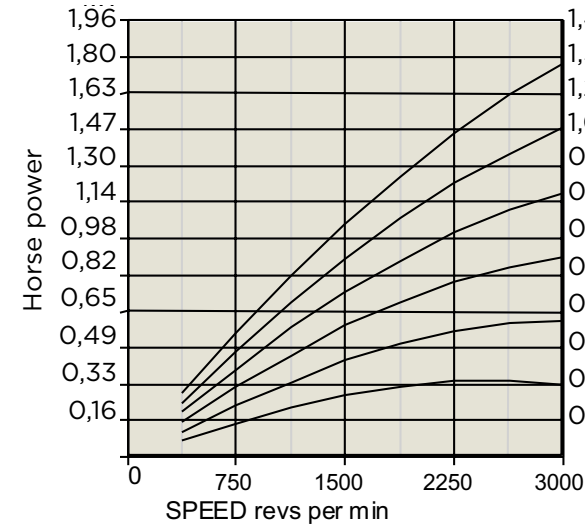

AIR CONSUMPTION - SPEED

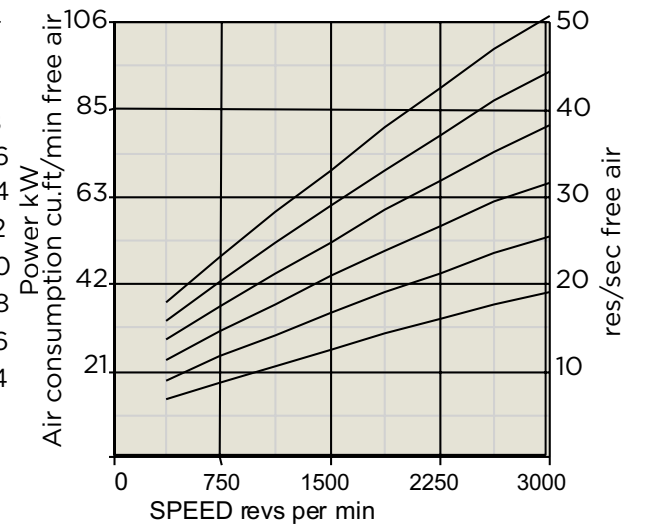

Muffler supplied with motor.

Motor is reversible.

ATTITUDE

The motor can be operated in all positions.

MAXIMUM TEMPERATURE

-20°C to +60°C

(-4°F to +140°F).

AIRLINE FILTRATION

Use 5 micron filtration or better.

MAXIMUM SPEED 3000 RPM

When operating above 50% of the maximum speed please consult your supplier.

DIMENSIONS V6-NL

MODEL VA6C Nema 56C Configuration

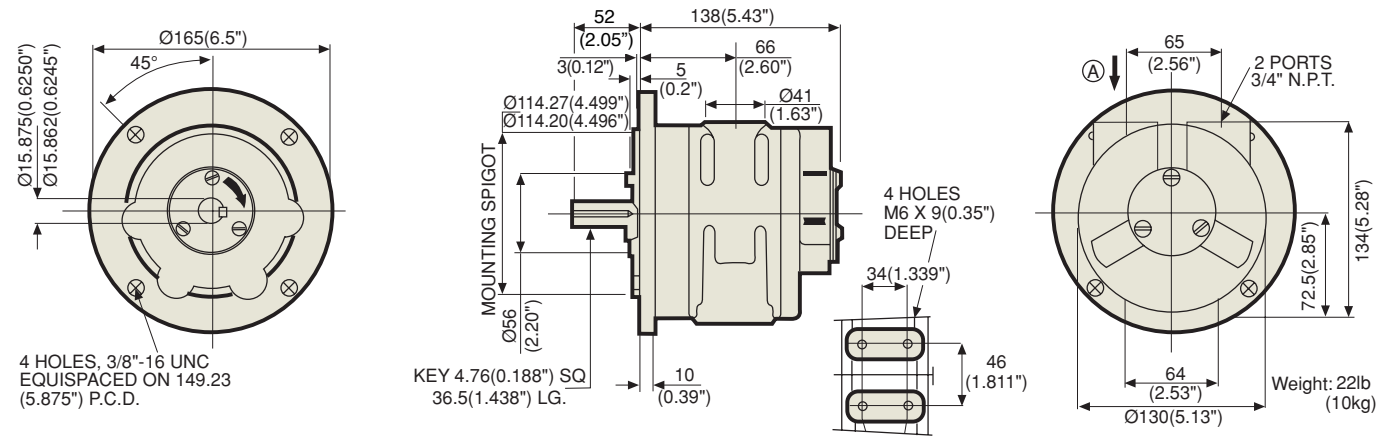

MODEL VA6J Foot Mounting Configuration

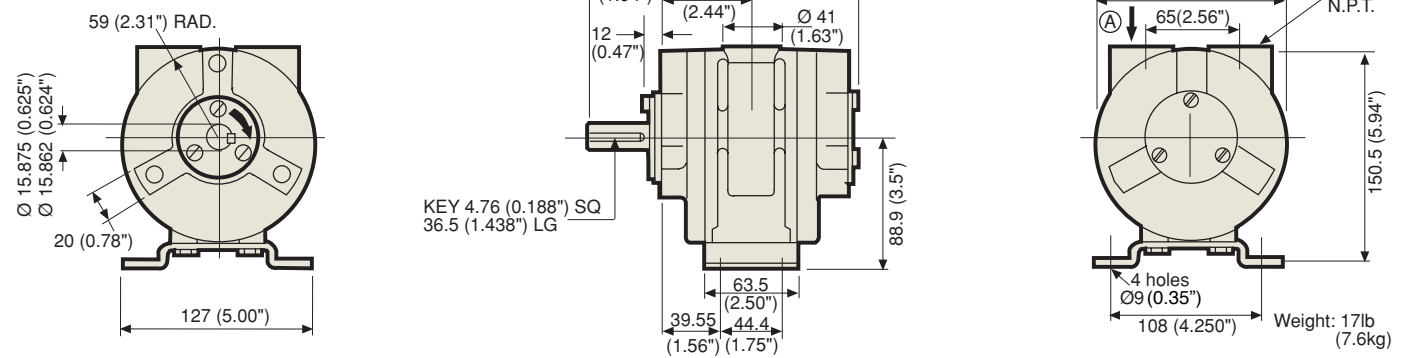

MODEL VA6X Face Mounting Configuration

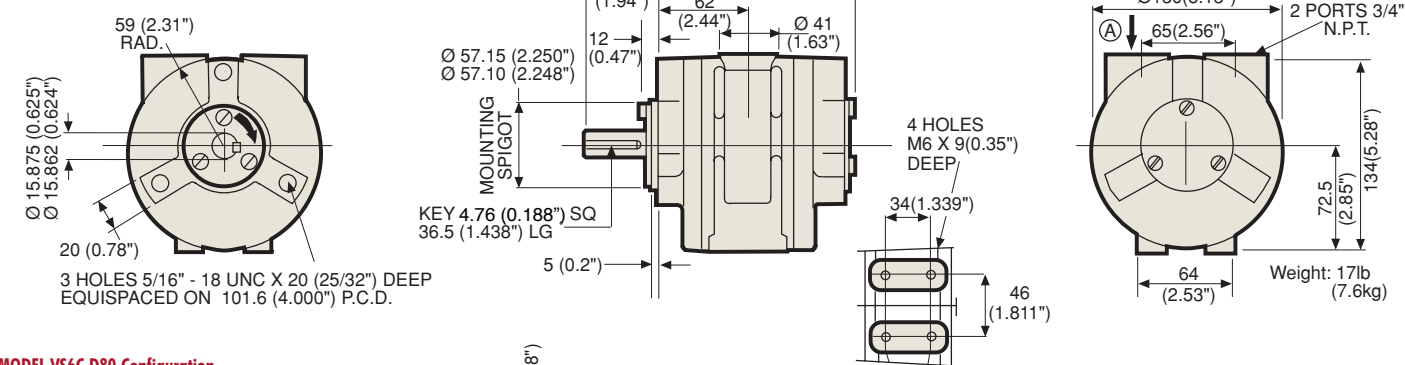

MODEL VS6C D80 Configuration

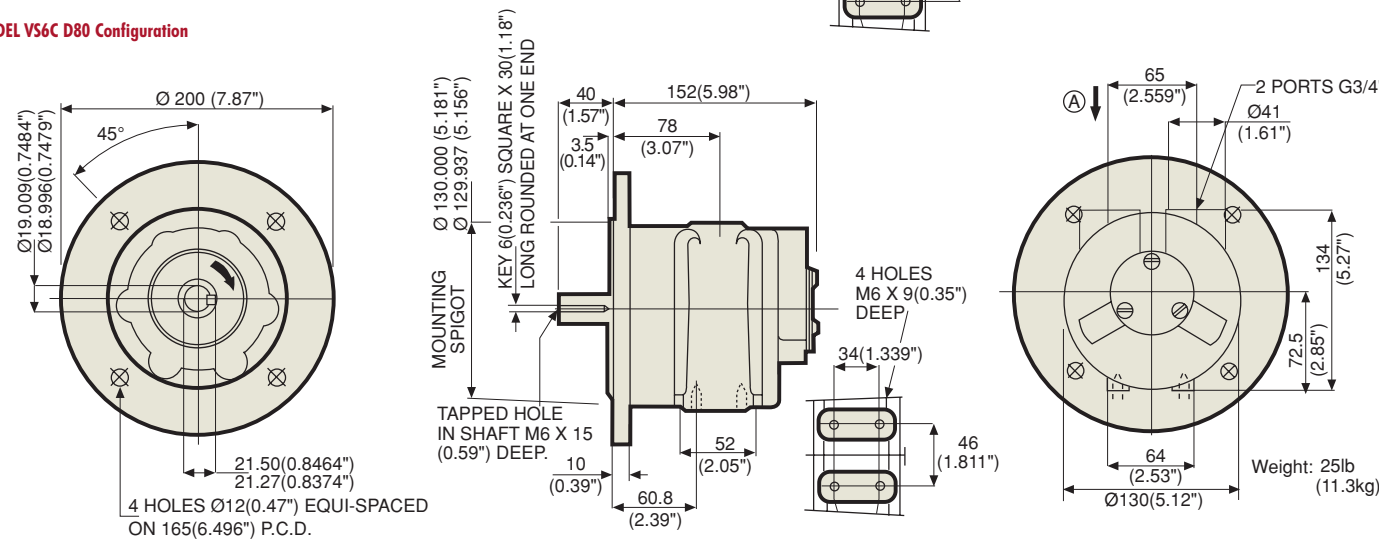

TORQUE - SPEED

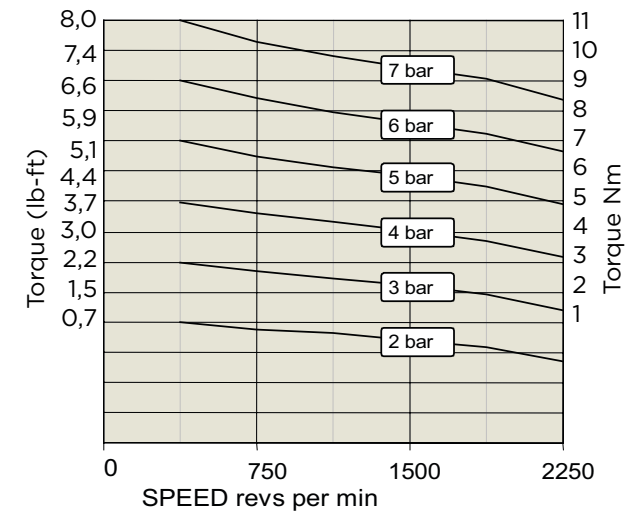

TORQUE - PRESSURE

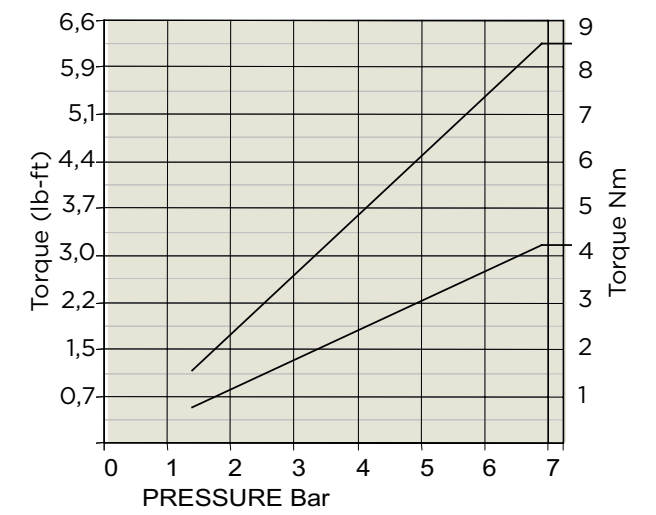

POWER - SPEED

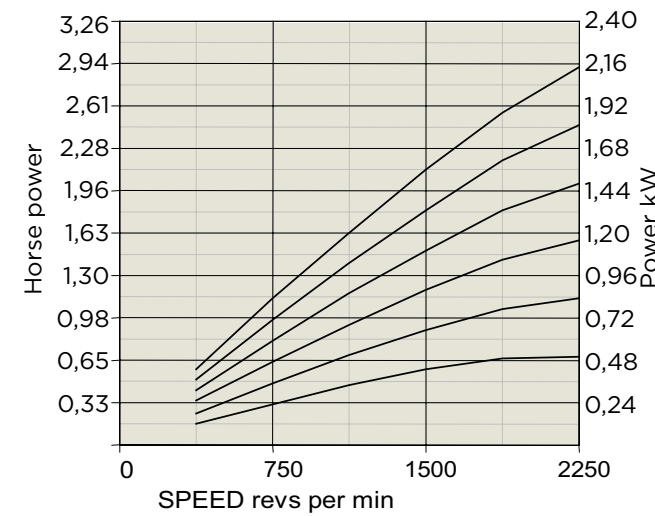

AIR CONSUMPTION - SF

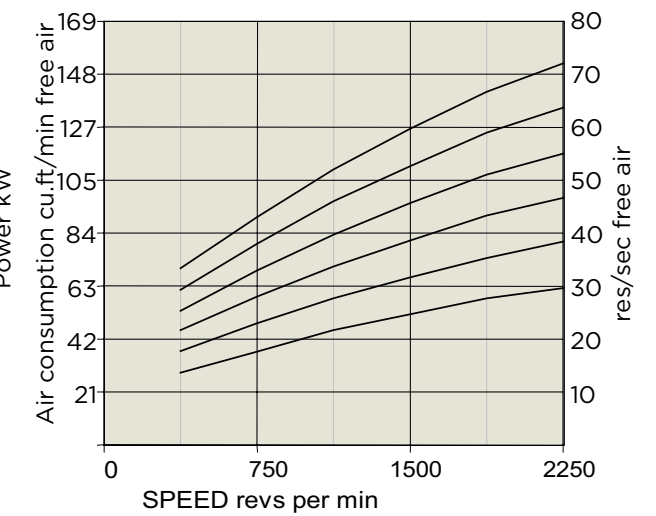

Muffler supplied with motor.

Motor is reversible.

ATTITUDE

The motor can be operated in all positions.

MAXIMUM TEMPERATURE

-20°C to +60°C

(-4°F to -140°F).

AIRLINE FILTRATION

Use 64 micron filtration or better.

MAXIMUM SPEED 2000 RPM

When operating above 50% of the maximum speed please consult your supplier.

DIMENSIONS V8-NL

MODEL VA8C I45 TC Configuration

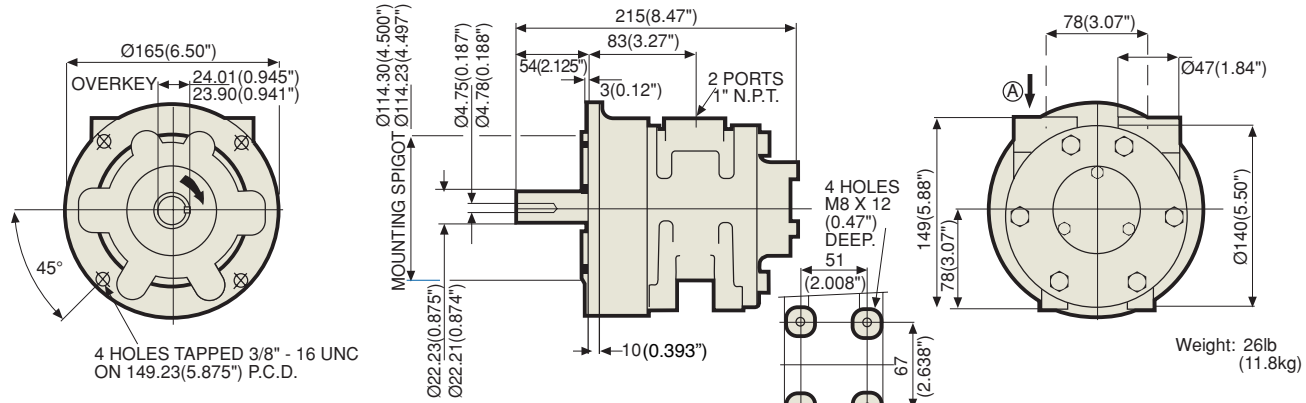

MODEL VA8J Foot Mounting Configuration

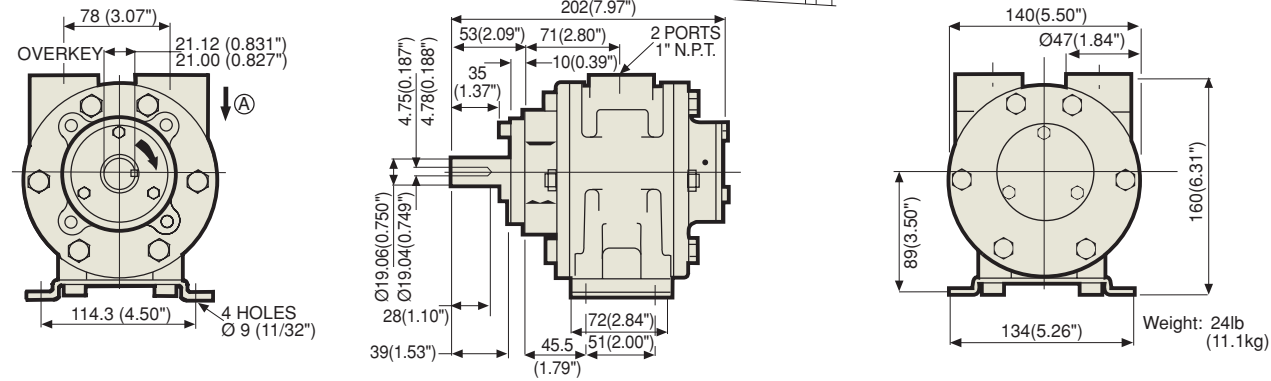

MODEL VA8X Face Mounting Configuration

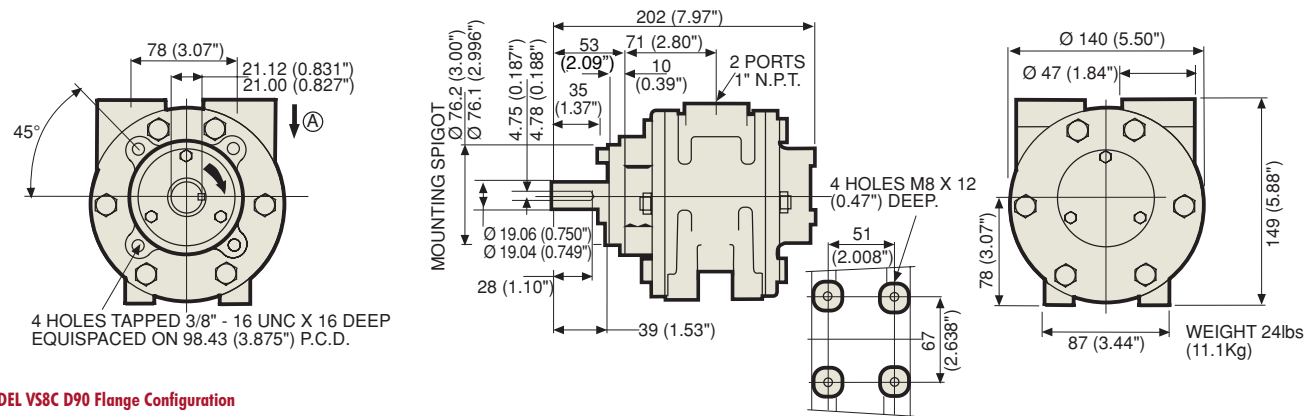

MODEL VS8C D90 Flange Configuration

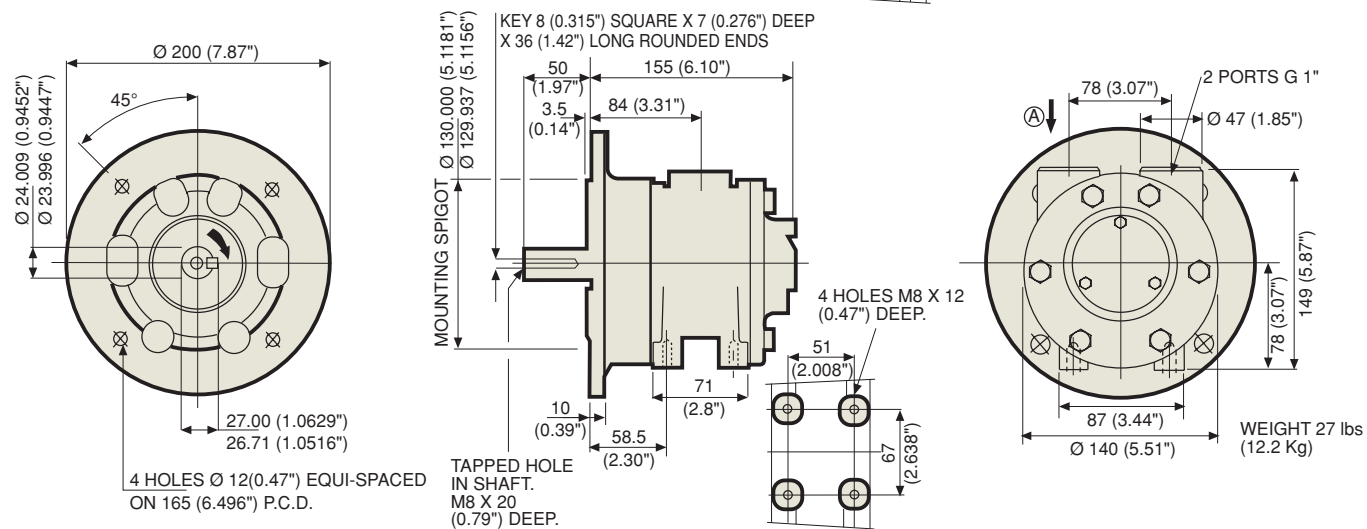

TORQUE - SPEED

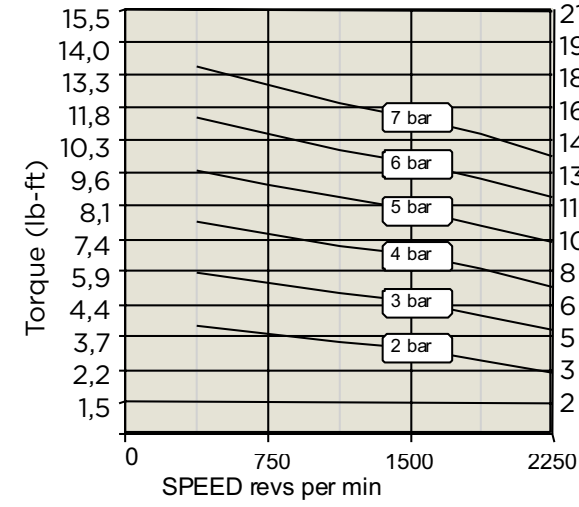

TORQUE - PRESSURE

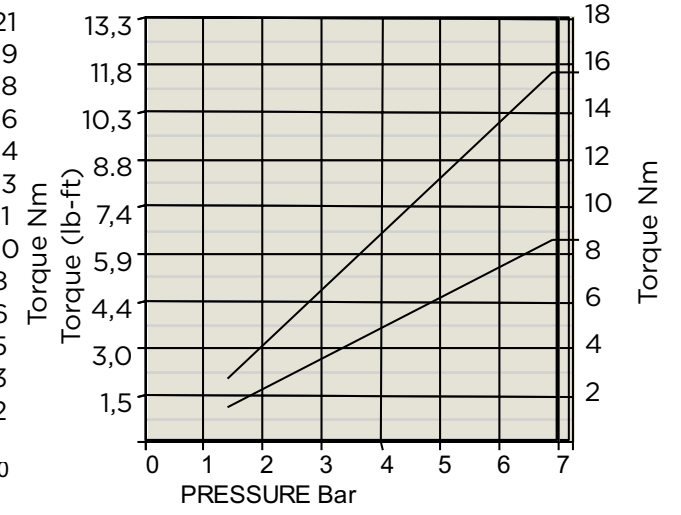

POWER - SPEED

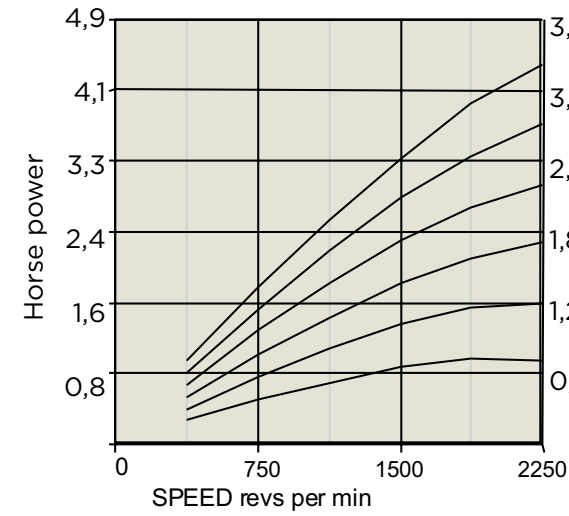

AIR CONSUMPTION - SPEED

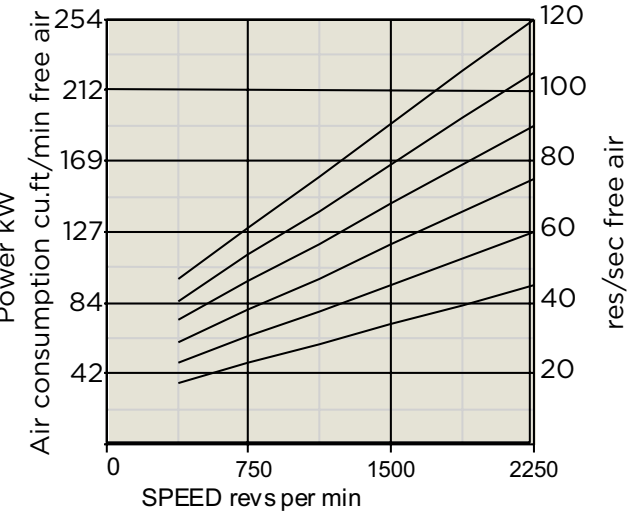

Muffler supplied with motor.

Motor is reversible.

ATTITUDE

The motor can be operated in all positions.

MAXIMUM TEMPERATURE

-20°C to +60°C

(-4°F to +140°F).

AIRLINE FILTRATION

Use 64 micron filtration or better.

MAXIMUM SPEED 2000 RPM

When operating above 50% of the maximum speed please consult your supplier.

DIMENSIONS V10-NL

MODEL VA10C 145 TC Configuration

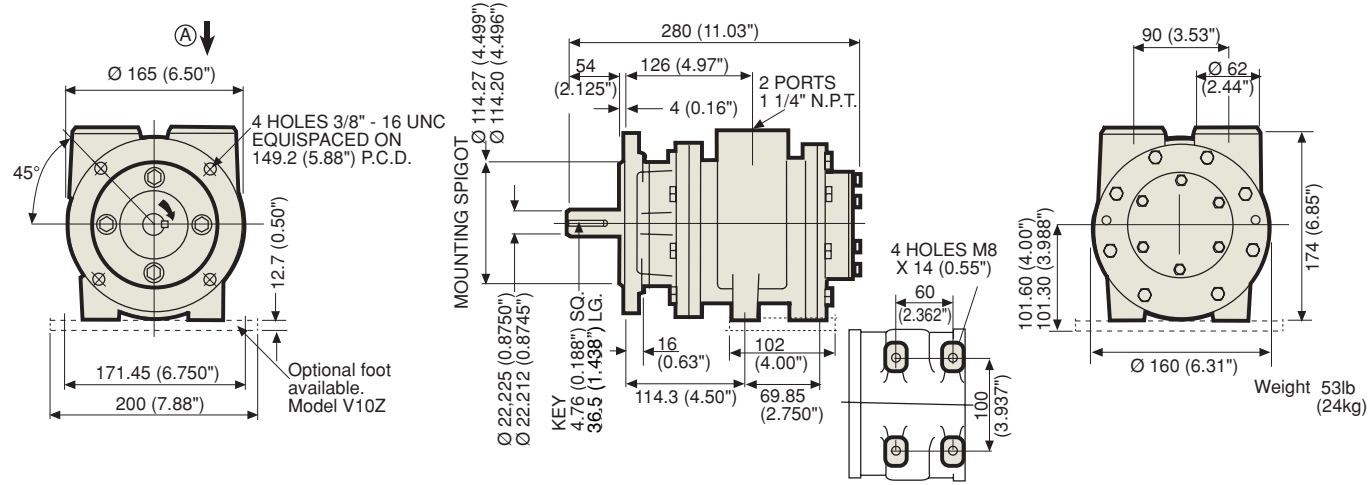

MODEL VA10J Foot Mounting Configuration

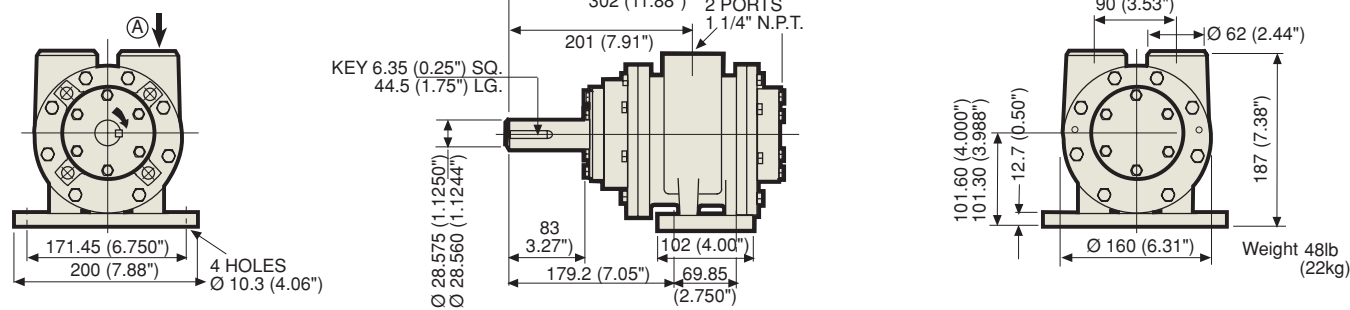

MODEL VA10X Face Mounting Configuration

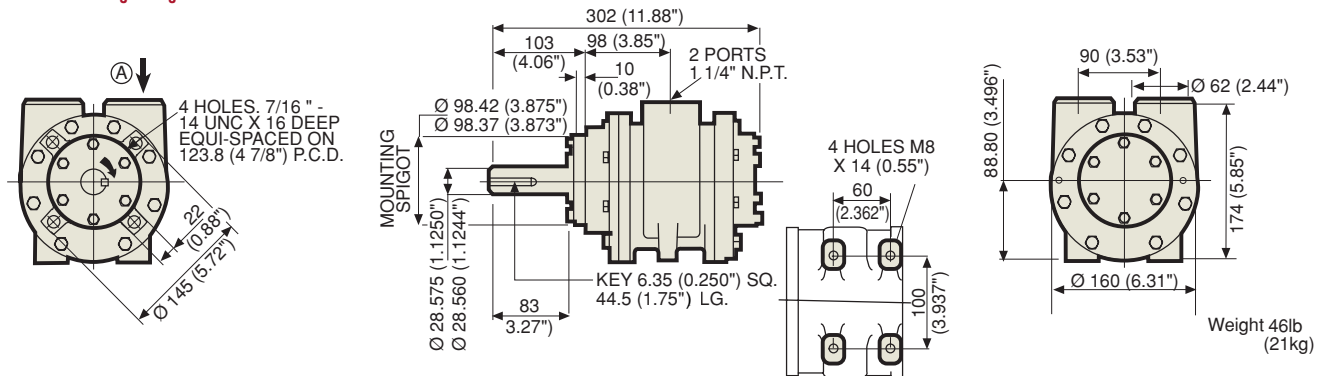

MODEL VS10C D100 Flange Configuration

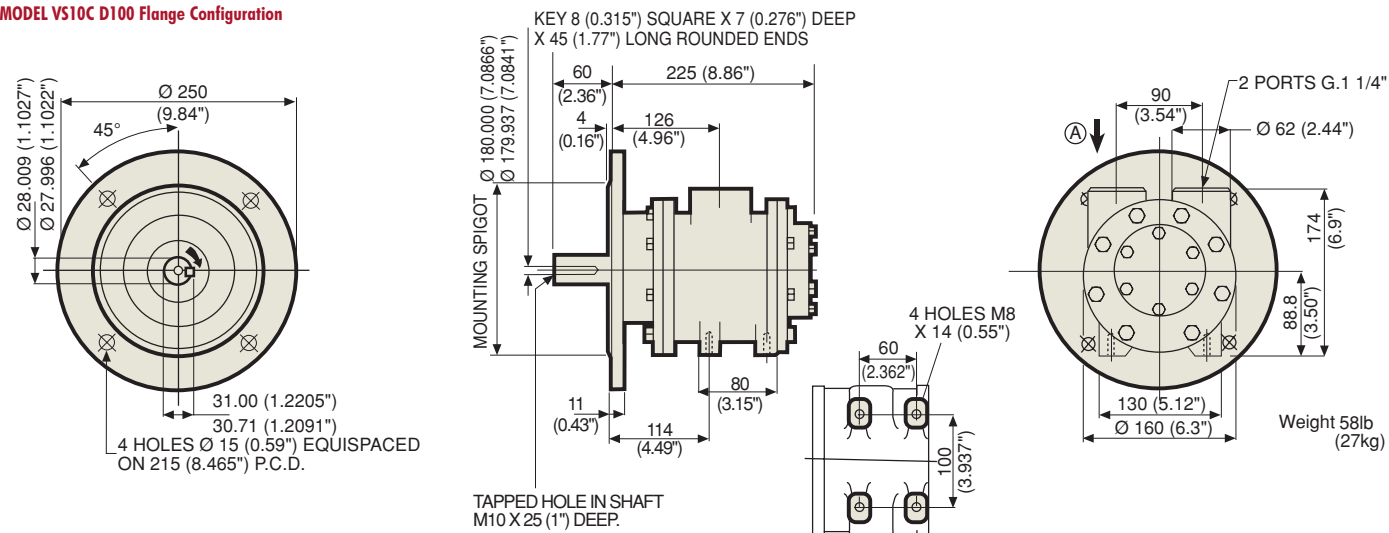

TORQUE - SPEED

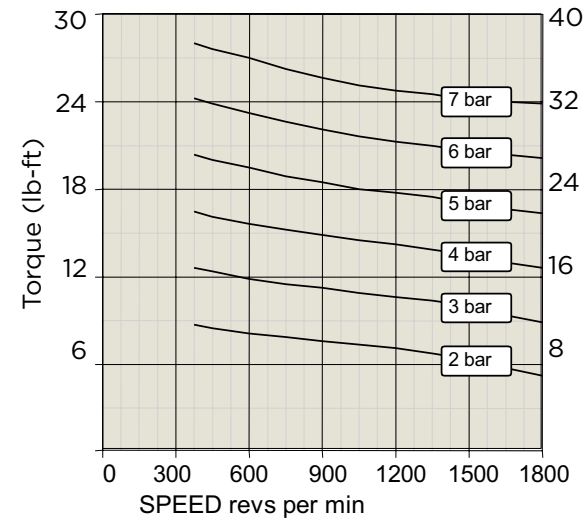

TORQUE - PRESSURE

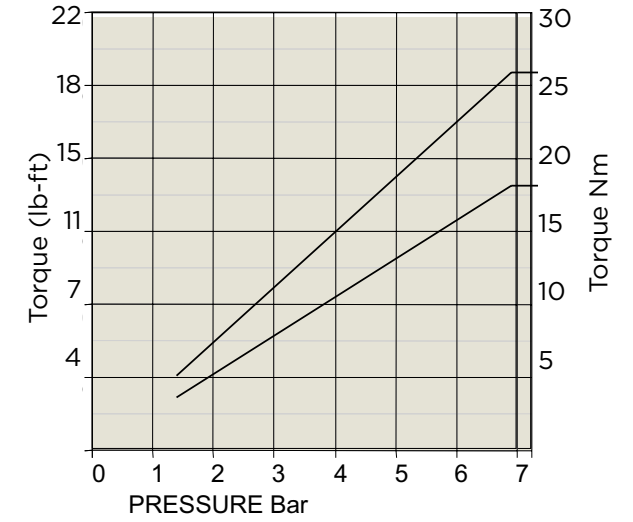

POWER - SPEED

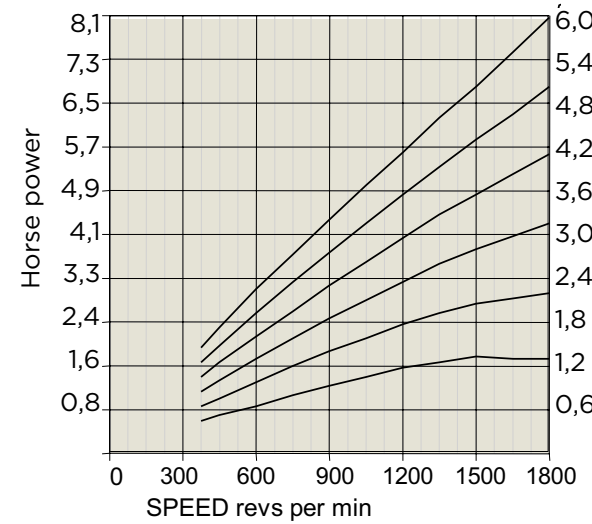

AIR CONSUMPTION - SPEED

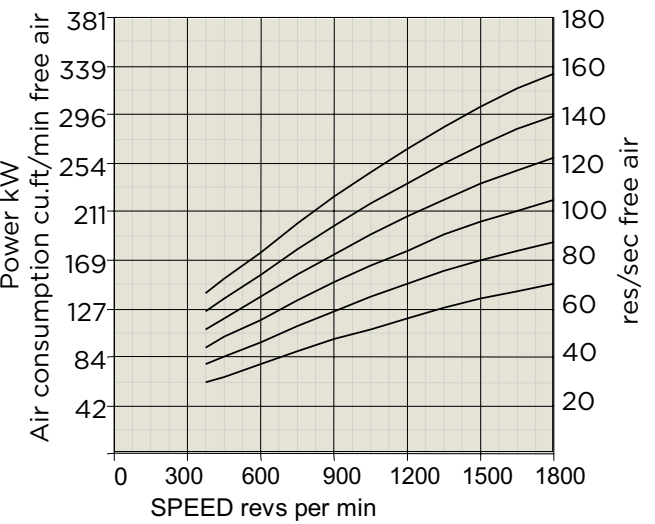

Muffler supplied with motor.

Motor is reversible.

ATTITUDE

The motor can be operated in all positions.

MAXIMUM TEMPERATURE

-20°C to +60°C

(-4°F to +140°F).

AIRLINE FILTRATION

Use 64 micron filtration or better.

MAXIMUM SPEED 1800 RPM

When operating above 50% of the maximum speed please consult your supplier.

KITS AND SPARE PARTS

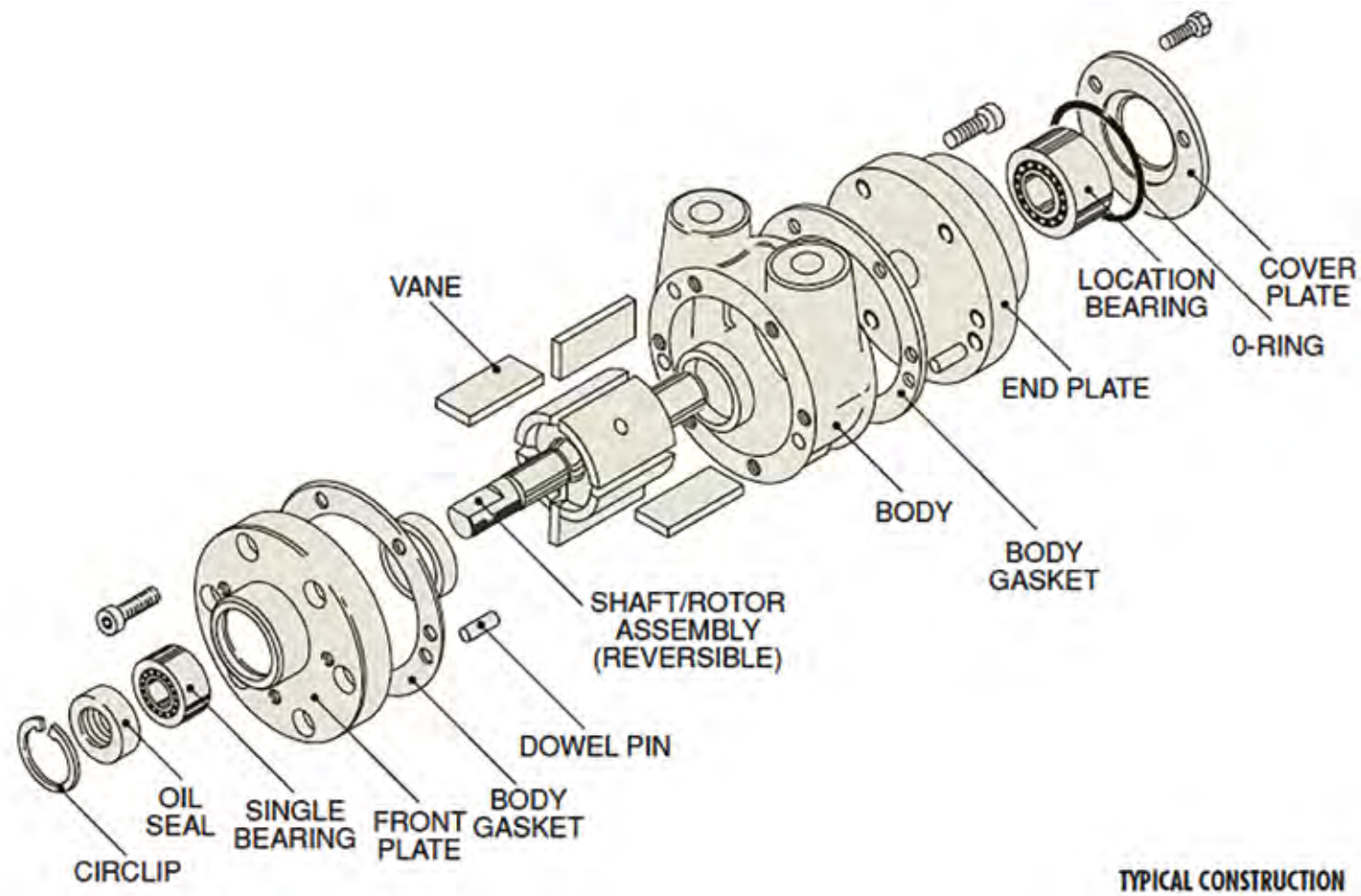

Revision kits and spare parts are available on request.

Service kit per type of motor	Kit number
GLOBE V1 serie	719-910
GLOBE V2 serie	729-910
GLOBE V4 serie	749-910
GLOBE V6 serie	769-910
GLOBE V8 serie	789-910
GLOBE V10 serie	799-910
GLOBE V12 serie	712-910



STAINLESS STEEL VANE AIR MOTORS

GLOBE Airmotors has developed a stainless steel addition to the standard and non lubricated vane air motors. These stainless steel vane air motors have the same dimensions and performances as the standard edition.

These stainless steel vane air motors are perfect for use in aggressive environments and food processing industry.

Please consult GLOBE Airmotors BV about the possibilities regarding the stainless steel vane air motors.





GLOBE GEARED VANE AIR MOTORS

The GLOBE geared vane air motors are available with a standard range of worm and coaxial gearboxes. They generate high torques and low speeds of rotation required in many applications. Power ranges up to 8.3kW/11,1HP at 6 bar/90psi air pressure.

The motor and gearbox are directly mounted onto each other, making them compact and resistant against the environment. GLOBE geared vane air motors are designed for smooth operation and are commonly used in mixing equipment, conveyor belts, hoists and winches, hose reels and turntables.

GLOBE geared vane air motors have many advantages including:

- Power ranges up to 8.3kW/11,1HP at 6 bar/90psi air pressure
- High nominal torque up to 1650Nm/1216 lbs.ft
- Speed of rotation as low as 7 rpm
- Easily variable and controllable speed and torque
- Perfect for applications in hazardous and aggressive environments
- ATEX certification ATEX II cat. 2 G&D T5 on request
- No damage by overload or repeated starting
- Can be used in stall conditions
- Superior power to weight ratio
- Instantly reversible
- Minimum maintenance
- High radial and axial loads permitted
- Oil free possible

Please contact GLOBE for special requests. We are known for our custom solutions.

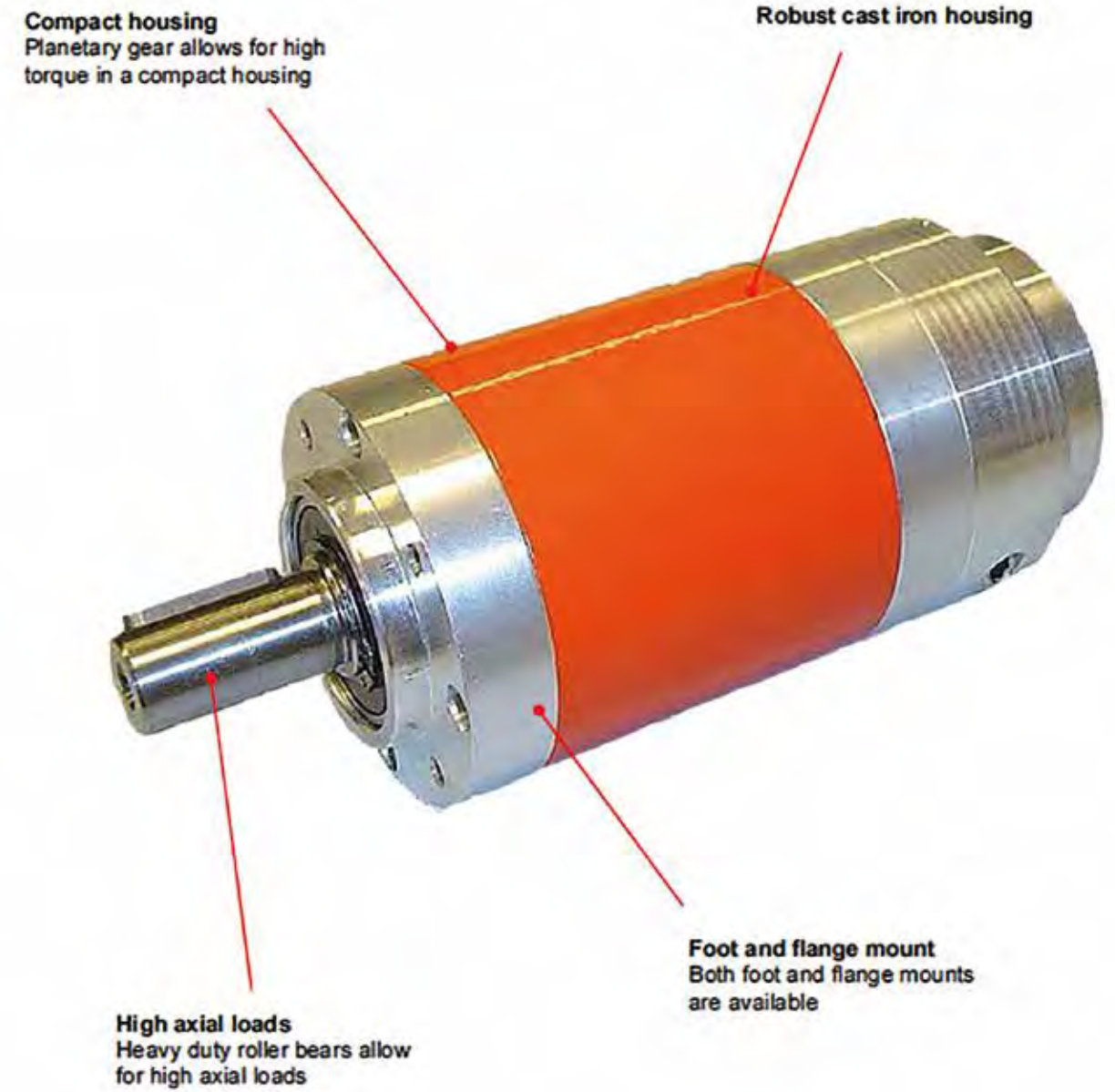
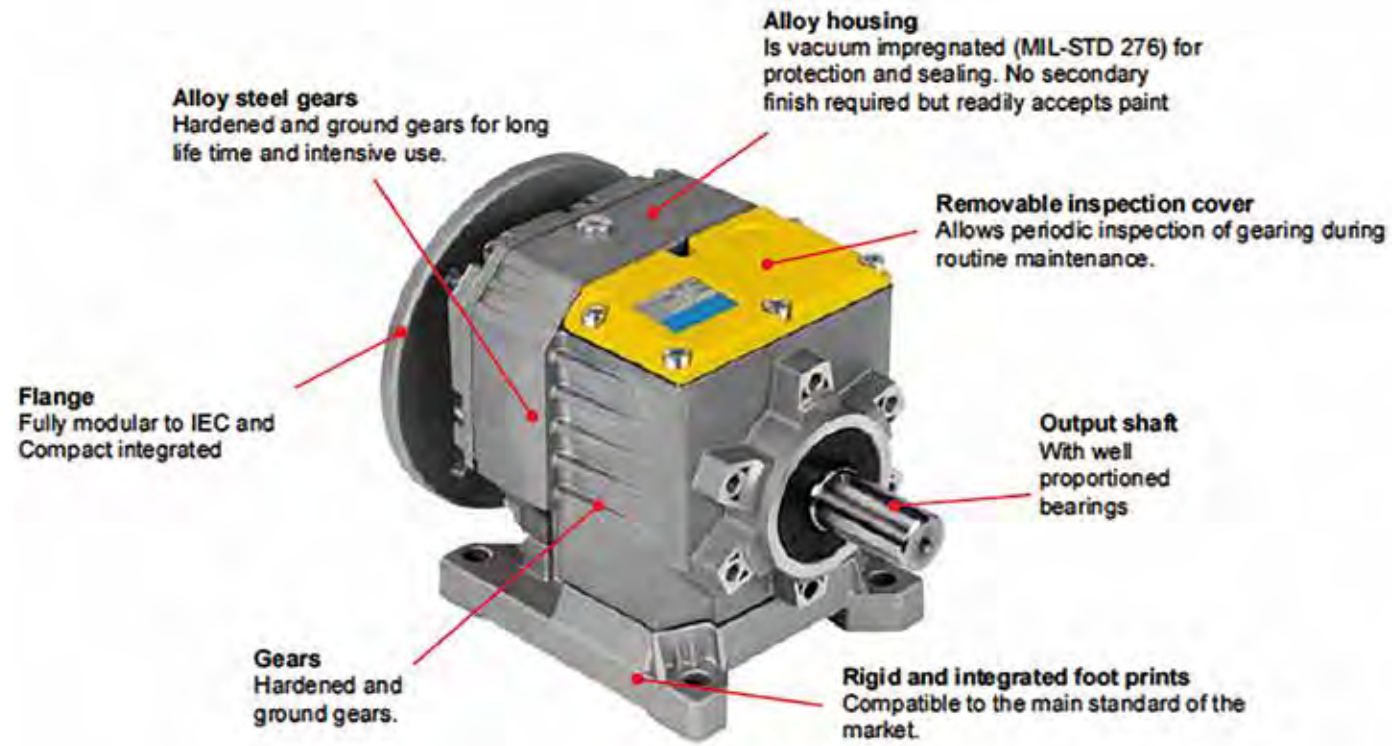
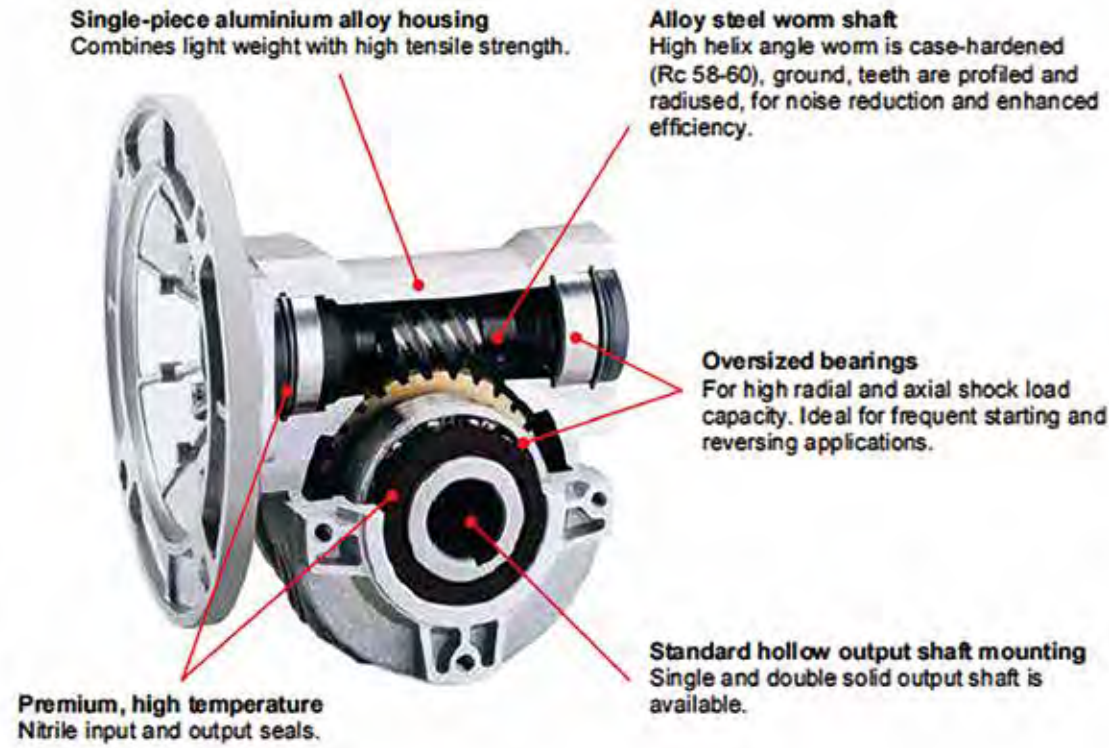

PERFORMANCES GLOBE VANE AIR MOTORS WORM GEARBOX

Ordering code flange model	Ordering code foot model	i	Power* (kW / hp)	Max. rpm**	Nominal torque* (Nm / lb-ft)	Min. starting torque (Nm / lb-ft)	Weight flange model (Kg / lb)	Weight foot model (Kg / lb)
GLOBE V4 + worm gear								
VS4DW63FG7	VS4DW63BG7	7	1.3kW / 1.8hp	430	30Nm / 22lb-ft	20Nm / 15lb-ft	11Kg / 24.2lb	12Kg / 26.4lb
VS4DW63FG15	VS4DW63BG15	15	1.3kW / 1.8hp	200	61Nm / 45lb-ft	35Nm / 26lb-ft	11Kg / 24.2lb	12Kg / 26.4lb
VS4DW63FG30	VS4DW63BG30	30	1.2kW / 1.6hp	100	110Nm / 81lb-ft	53Nm / 39lb-ft	11Kg / 24.2lb	12Kg / 26.4lb
VS4DW63FG45	VS4DW63BG45	45	1.1kW / 1.5hp	65	155Nm / 114lb-ft	67Nm / 49lb-ft	11Kg / 24.2lb	12Kg / 26.4lb
VS4DW85FG67	VS4DW85BG67	67	1kW / 1.3hp	45	210Nm / 155lb-ft	80Nm / 59lb-ft	17Kg / 37.4lb	19Kg / 41.8lb
VS4DW85FG74	VS4DW85BG74	74	0.9kW / 1.2hp	40	220Nm / 162lb-ft	83Nm / 61lb-ft	17Kg / 37.4lb	19Kg / 41.8lb
GLOBE V6 + worm gear								
VS6DW63FG7	VS6DW63BG7	7	2.7kW / 3.7hp	430	60Nm / 44lb-ft	40Nm / 29lb-ft	17Kg / 37.4lb	18Kg / 39.6lb
VS6DW63FG15	VS6DW63BG15	15	2.6kW / 3.5hp	200	120Nm / 88lb-ft	70Nm / 52lb-ft	17Kg / 37.4lb	18Kg / 39.6lb
VS6DW85FG28	VS6DW85BG28	28	2.5kW / 3.4hp	105	220Nm / 162lb-ft	110Nm / 81lb-ft	23Kg / 50.6lb	25Kg / 55lb
VS6DW85FG46	VS6DW85BG46	46	2.3kW / 3.1hp	65	330Nm / 243lb-ft	160Nm / 118lb-ft	23Kg / 50.6lb	25Kg / 55lb
VS6DW110FG64	VS6DW110BG64	64	2.3kW / 3.1hp	47	460Nm / 339lb-ft	195Nm / 144lb-ft	39Kg / 85.8lb	44Kg / 96.8lb
VS6DW110FG84	VS6DW110BG84	84	2.2kW / 3.0hp	35	575Nm / 424lb-ft	220Nm / 162lb-ft	39Kg / 85.8lb	44Kg / 96.8lb
GLOBE V8 + worm gear								
VS8DW85FG7	VS8DW85BG7	7	4kW / 5.4hp	430	90Nm / 66lb-ft	75Nm / 55lb-ft	24Kg / 52.8lb	26Kg / 57.2lb
VS8DW85FG14	VS8DW85BG14	14	3.9kW / 5.3hp	215	175Nm / 129lb-ft	125Nm / 92lb-ft	24Kg / 52.8lb	26Kg / 57.2lb
VS8DW110FG30	VS8DW110BG30	30	3.7kW / 5.0hp	100	350Nm / 258lb-ft	200Nm / 147lb-ft	40Kg / 88lb	45Kg / 99lb
VS8DW110FG45	VS8DW110BG45	45	3.6kW / 4.9hp	65	515Nm / 380lb-ft	295Nm / 217lb-ft	40Kg / 88lb	45Kg / 99lb
VS8DW110FG64	VS8DW110BG64	64	3.3kW / 4.5hp	47	690Nm / 508lb-ft	365Nm / 269lb-ft	40Kg / 88lb	45Kg / 99lb
GLOBE V10 + worm gear								
VS10DW85FG7	VS10DW85BG7	7	7.2kW / 9.8hp	340	210Nm / 155lb-ft	150Nm / 111lb-ft	39Kg / 85.8lb	41Kg / 90.2lb
VS10DW110FG16	VS10DW110BG16	16	7kW / 9.5hp	150	460Nm / 339lb-ft	290Nm / 214lb-ft	55Kg / 121lb	60Kg / 132lb
VS10DW110FG23	VS10DW110BG23	23	6.9kW / 9.4hp	105	650Nm / 479lb-ft	405Nm / 298lb-ft	55Kg / 121lb	60Kg / 132lb

* Power and nominal torque at 6 bar and motor input speed of 3000 rpm (V4, V6, V8) and 2400 rpm (V10).

** In applications where the motor input speed exceeds 2200 rpm, only intermittent use is tolerated.



DIMENSIONS GLOBE VANE AIR MOTORS WORM GEARBOX - FLANGE MODEL

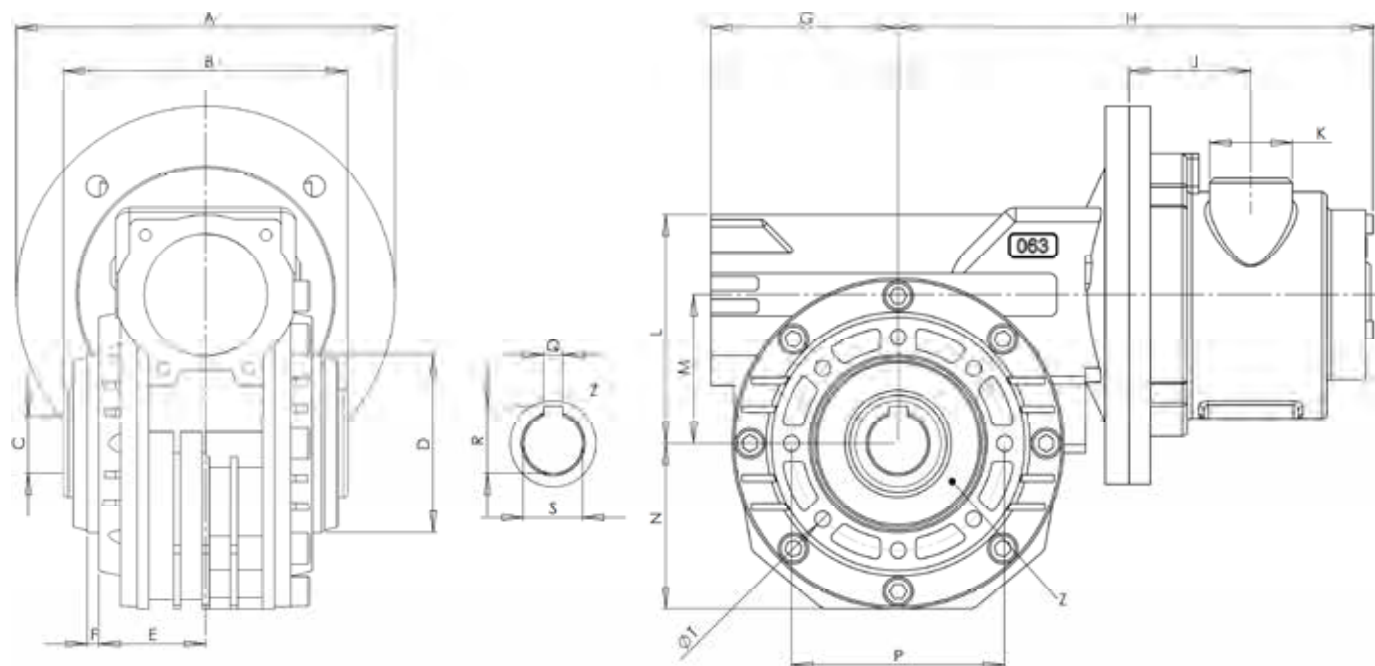

Ordering code	A	B	C	D	E	F	G	H	J
VS4DW63FG7	160 (6.29")	120 (4.72")	25H8 (0.98")	75h8 (2.95")	45 (1.77")	5 (0.19")	79 (3.11")	203 (7.99")	55 (2.16")
VS4DW63FG15	160 (6.29")	120 (4.72")	25H8 (0.98")	75h8 (2.95")	45 (1.77")	5 (0.19")	79 (3.11")	203 (7.99")	55 (2.16")
VS4DW63FG30	160 (6.29")	120 (4.72")	25H8 (0.98")	75h8 (2.95")	45 (1.77")	5 (0.19")	79 (3.11")	203 (7.99")	55 (2.16")
VS4DW63FG45	160 (6.29")	120 (4.72")	25H8 (0.98")	75h8 (2.95")	45 (1.77")	5 (0.19")	79 (3.11")	203 (7.99")	55 (2.16")
VS4DW85FG67	160 (6.29")	135 (5.31")	35H8 (1.37")	110h8 (4.33")	64 (2.52")	3.5 (0.14")	98 (3.86")	227 (8.94")	55 (2.16")
VS4DW85FG74	160 (6.29")	135 (5.31")	35H8 (1.37")	110h8 (4.33")	64 (2.52")	3.5 (0.14")	98 (3.86")	227 (8.94")	55 (2.16")
VS6DW63FG7	200 (7.87")	120 (4.72")	25H8 (0.98")	75h8 (2.95")	45 (1.77")	5 (0.19")	79 (3.11")	252 (9.92")	78 (3.07")
VS6DW63FG15	200 (7.87")	120 (4.72")	25H8 (0.98")	75h8 (2.95")	45 (1.77")	5 (0.19")	79 (3.11")	252 (9.92")	78 (3.07")
VS6DW85FG28	200 (7.87")	135 (5.31")	35H8 (1.37")	110h8 (4.33")	64 (2.52")	3.5 (0.14")	98 (3.86")	276 (10.86")	78 (3.07")
VS6DW85FG46	200 (7.87")	135 (5.31")	35H8 (1.37")	110h8 (4.33")	64 (2.52")	3.5 (0.14")	98 (3.86")	276 (10.86")	78 (3.07")
VS6DW110FG64	200 (7.87")	155 (6.10")	42H8 (1.65")	130h8 (5.12")	74 (2.91")	3.5 (0.14")	118 (4.64")	296 (11.65")	78 (3.07")
VS6DW110FG84	200 (7.87")	155 (6.10")	42H8 (1.65")	130h8 (5.12")	74 (2.91")	3.5 (0.14")	118 (4.64")	296 (11.65")	78 (3.07")
VS8DW85FG7	200 (7.87")	135 (5.31")	35H8 (1.37")	110h8 (4.33")	64 (2.52")	3.5 (0.14")	98 (3.86")	279 (10.98")	84 (3.31")
VS8DW85FG14	200 (7.87")	135 (5.31")	35H8 (1.37")	110h8 (4.33")	64 (2.52")	3.5 (0.14")	98 (3.86")	279 (10.98")	84 (3.31")
VS8DW110FG30	200 (7.87")	155 (6.10")	42H8 (1.65")	130h8 (5.12")	74 (2.91")	3.5 (0.14")	118 (4.64")	299 (11.77")	84 (3.31")
VS8DW110FG45	200 (7.87")	155 (6.10")	42H8 (1.65")	130h8 (5.12")	74 (2.91")	3.5 (0.14")	118 (4.64")	299 (11.77")	84 (3.31")
VS8DW110FG64	200 (7.87")	155 (6.10")	42H8 (1.65")	130h8 (5.12")	74 (2.91")	3.5 (0.14")	118 (4.64")	299 (11.77")	84 (3.31")
VS10DW85FG7	250 (9.84")	135 (5.31")	35H8 (1.37")	110h8 (4.33")	64 (2.52")	3.5 (0.14")	98 (3.86")	349 (13.74")	126 (4.96")
VS10DW110FG16	250 (9.84")	155 (6.10")	42H8 (1.65")	130h8 (5.12")	74 (2.91")	3.5 (0.14")	118 (4.64")	369 (14.53")	126 (4.96")
VS10DW110FG23	250 (9.84")	155 (6.10")	42H8 (1.65")	130h8 (5.12")	74 (2.91")	3.5 (0.14")	118 (4.64")	369 (14.53")	126 (4.96")

Ordering code	K	L	M	N	P	Q	R	S	T
VS4DW63FG7	G1/2"	100 (3.94")	63 (2.48")	70 (2.75")	90 (3.54")	8 (0.31")	28.3 (1.11")	25H8 (0.98")	8xM8x17 (0.31"xM8x0.67")
VS4DW63FG15	G1/2"	100 (3.94")	63 (2.48")	70 (2.75")	90 (3.54")	8 (0.31")	28.3 (1.11")	25H8 (0.98")	8xM8x17 (0.31"xM8x0.67")
VS4DW63FG30	G1/2"	100 (3.94")	63 (2.48")	70 (2.75")	90 (3.54")	8 (0.31")	28.3 (1.11")	25H8 (0.98")	8xM8x17 (0.31"xM8x0.67")
VS4DW63FG45	G1/2"	100 (3.94")	63 (2.48")	70 (2.75")	90 (3.54")	8 (0.31")	28.3 (1.11")	25H8 (0.98")	8xM8x17 (0.31"xM8x0.67")
VS4DW85FG67	G1/2"	138 (5.43")	85 (3.34")	94.5 (3.72")	130 (5.12")	10 (0.39")	38.3 (1.51")	35H8 (1.37")	4xM10x18 (0.16"xM10x0.71")
VS4DW85FG74	G1/2"	138 (5.43")	85 (3.34")	94.5 (3.72")	130 (5.12")	10 (0.39")	38.3 (1.51")	35H8 (1.37")	4xM10x18 (0.16"xM10x0.71")
VS6DW63FG7	G3/4"	100 (3.94")	63 (2.48")	70 (2.75")	90 (3.54")	8 (0.31")	28.3 (1.11")	25H8 (0.98")	8xM8x17 (0.31"xM8x0.67")
VS6DW63FG15	G3/4"	100 (3.94")	63 (2.48")	70 (2.75")	90 (3.54")	8 (0.31")	28.3 (1.11")	25H8 (0.98")	8xM8x17 (0.31"xM8x0.67")
VS6DW85FG28	G3/4"	138 (5.43")	85 (3.34")	94.5 (3.72")	130 (5.12")	10 (0.39")	38.3 (1.51")	35H8 (1.37")	4xM10x18 (0.16"xM10x0.71")
VS6DW85FG46	G3/4"	138 (5.43")	85 (3.34")	94.5 (3.72")	130 (5.12")	10 (0.39")	38.3 (1.51")	35H8 (1.37")	4xM10x18 (0.16"xM10x0.71")
VS6DW110FG64	G3/4"	163 (6.42")	110 (4.33")	116 (4.56")	165 (6.49")	12 (0.47")	45.3 (1.78")	42H8 (1.65")	8xM12x30 (0.31"xM12x1.18")
VS6DW110FG84	G3/4"	163 (6.42")	110 (4.33")	116 (4.56")	165 (6.49")	12 (0.47")	45.3 (1.78")	42H8 (1.65")	8xM12x30 (0.31"xM12x1.18")
VS8DW85FG7	G1"	138 (5.43")	85 (3.34")	94.5 (3.72")	130 (5.12")	10 (0.39")	38.3 (1.51")	35H8 (1.37")	4xM10x18 (0.16"xM10x0.71")
VS8DW85FG14	G1"	138 (5.43")	85 (3.34")	94.5 (3.72")	130 (5.12")	10 (0.39")	38.3 (1.51")	35H8 (1.37")	4xM10x18 (0.16"xM10x0.71")
VS8DW110FG30	G1"	163 (6.42")	110 (4.33")	116 (4.56")	165 (6.49")	12 (0.47")	45.3 (1.78")	42H8 (1.65")	8xM12x30 (0.31"xM12x1.18")
VS8DW110FG45	G1"	163 (6.42")	110 (4.33")	116 (4.56")	165 (6.49")	12 (0.47")	45.3 (1.78")	42H8 (1.65")	8xM12x30 (0.31"xM12x1.18")
VS8DW110FG64	G1"	163 (6.42")	110 (4.33")	116 (4.56")	165 (6.49")	12 (0.47")	45.3 (1.78")	42H8 (1.65")	8xM12x30 (0.31"xM12x1.18")
VS10DW85FG7	G 1 1/4"	138 (5.43")	85 (3.34")	94.5 (3.72")	130 (5.12")	10 (0.39")	38.3 (1.51")	35H8 (1.37")	4xM10x18 (0.16"xM10x0.71")
VS10DW110FG16	G 1 1/4"	163 (6.42")	110 (4.33")	116 (4.56")	165 (6.49")	12 (0.47")	45.3 (1.78")	42H8 (1.65")	8xM12x30 (0.31"xM12x1.18")
VS10DW110FG23	G 1 1/4"	163 (6.42")	110 (4.33")	116 (4.56")	165 (6.49")	12 (0.47")	45.3 (1.78")	42H8 (1.65")	8xM12x30 (0.31"xM12x0.67")

DIMENSIONS GLOBE VANE AIR MOTORS WORM GEARBOX - FOOT MODEL

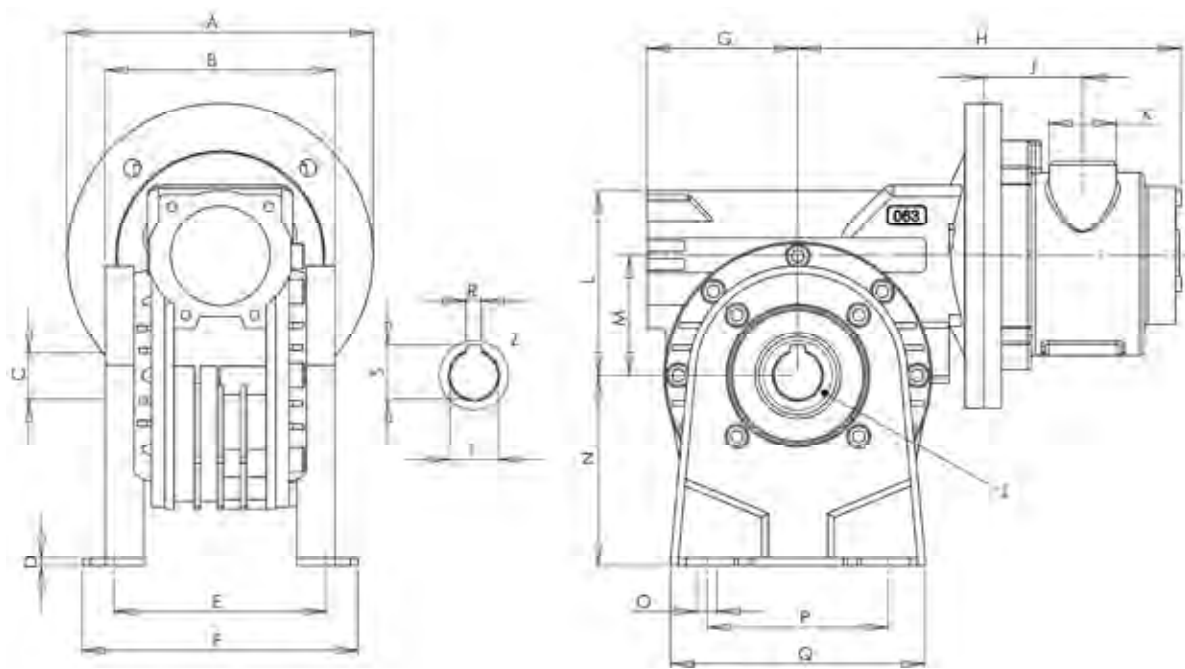

Ordering Code	A	B	C	D	E	F	G	H	J
VS4DW63BG7	160 (6.29")	120 (4.72")	25H8 (0.98")	4 (0.16")	110 (4.33")	5 (0.19")	79 (3.11")	203 (7.99")	55 (2.16")
VS4DW63BG15	160 (6.29")	120 (4.72")	25H8 (0.98")	4 (0.16")	110 (4.33")	5 (0.19")	79 (3.11")	203 (7.99")	55 (2.16")
VS4DW63BG30	160 (6.29")	120 (4.72")	25H8 (0.98")	4 (0.16")	110 (4.33")	5 (0.19")	79 (3.11")	203 (7.99")	55 (2.16")
VS4DW63BG45	160 (6.29")	120 (4.72")	25H8 (0.98")	4 (0.16")	110 (4.33")	5 (0.19")	79 (3.11")	203 (7.99")	55 (2.16")
VS4DW85BG67	160 (6.29")	135 (5.31")	35H8 (1.37")	5 (0.19")	145 (5.71")	3.5 (0.14")	98 (3.86")	227 (8.94")	55 (2.16")
VS4DW85BG74	160 (6.29")	135 (5.31")	35H8 (1.37")	5 (0.19")	145 (5.71")	3.5 (0.14")	98 (3.86")	227 (8.94")	55 (2.16")
VS6DW63BG7	200 (7.87")	120 (4.72")	25H8 (0.98")	4 (0.16")	110 (4.33")	5 (0.19")	79 (3.11")	252 (9.92")	78 (3.07")
VS6DW63BG15	200 (7.87")	120 (4.72")	25H8 (0.98")	4 (0.16")	110 (4.33")	5 (0.19")	79 (3.11")	252 (9.92")	78 (3.07")
VS6DW85BG28	200 (7.87")	135 (5.31")	35H8 (1.37")	5 (0.19")	145 (5.71")	3.5 (0.14")	98 (3.86")	276 (10.86")	78 (3.07")
VS6DW85BG46	200 (7.87")	135 (5.31")	35H8 (1.37")	5 (0.19")	145 (5.71")	3.5 (0.14")	98 (3.86")	276 (10.86")	78 (3.07")
VS6DW110BG64	200 (7.87")	155 (6.10")	42H8 (1.65")	22 (0.86")	180 (7.10")	3.5 (0.14")	118 (4.64")	296 (11.65")	78 (3.07")
VS6DW110BG84	200 (7.87")	155 (6.10")	42H8 (1.65")	22 (0.86")	180 (7.10")	3.5 (0.14")	118 (4.64")	296 (11.65")	78 (3.07")
VS8DW85BG7	200 (7.87")	135 (5.31")	35H8 (1.37")	5 (0.19")	145 (5.71")	3.5 (0.14")	98 (3.86")	279 (10.98")	84 (3.31")
VS8DW85BG14	200 (7.87")	135 (5.31")	35H8 (1.37")	5 (0.19")	145 (5.71")	3.5 (0.14")	98 (3.86")	279 (10.98")	84 (3.31")
VS8DW110BG30	200 (7.87")	155 (6.10")	42H8 (1.65")	22 (0.86")	180 (7.10")	3.5 (0.14")	118 (4.64")	299 (11.77")	84 (3.31")
VS8DW110BG45	200 (7.87")	155 (6.10")	42H8 (1.65")	22 (0.86")	180 (7.10")	3.5 (0.14")	118 (4.64")	299 (11.77")	84 (3.31")
VS8DW110BG64	200 (7.87")	155 (6.10")	42H8 (1.65")	22 (0.86")	180 (7.10")	3.5 (0.14")	118 (4.64")	299 (11.77")	84 (3.31")
VS10DW85BG7	250 (9.84")	135 (5.31")	35H8 (1.37")	5 (0.19")	145 (5.71")	3.5 (0.14")	98 (3.86")	349 (13.74")	126 (4.96")
VS10DW110BG16	250 (9.84")	155 (6.10")	42H8 (1.65")	22 (0.86")	180 (7.10")	3.5 (0.14")	118 (4.64")	369 (14.53")	126 (4.96")
VS10DW110BG23	250 (9.84")	155 (6.10")	42H8 (1.65")	22 (0.86")	180 (7.10")	3.5 (0.14")	118 (4.64")	369 (14.53")	126 (4.96")

Ordering Code	K	L	M	N	O	P	Q	R	S	T
VS4DW63FG7	G1/2"	100 (3.94")	63 (2.48")	100 (3.94")	10,5 (0.41")	95 (3.74")	133 (5.23")	8 (0.31")	28.3 (1.11")	25H8 (0.98")
VS4DW63FG15	G1/2"	100 (3.94")	63 (2.48")	100 (3.94")	10,5 (0.41")	95 (3.74")	133 (5.23")	8 (0.31")	28.3 (1.11")	25H8 (0.98")
VS4DW63FG30	G1/2"	100 (3.94")	63 (2.48")	100 (3.94")	10,5 (0.41")	95 (3.74")	133 (5.23")	8 (0.31")	28.3 (1.11")	25H8 (0.98")
VS4DW63FG45	G1/2"	100 (3.94")	63 (2.48")	100 (3.94")	10,5 (0.41")	95 (3.74")	133 (5.23")	8 (0.31")	28.3 (1.11")	25H8 (0.98")
VS4DW85FG67	G1/2"	138 (5.43")	85 (3.34")	142 (5.60")	10,5 (0.41")	140 (5.51")	180 (7.10")	10 (0.39")	38.3 (1.51")	35H8 (1.37")
VS4DW85FG74	G1/2"	138 (5.43")	85 (3.34")	142 (5.60")	10,5 (0.41")	140 (5.51")	180 (7.10")	10 (0.39")	38.3 (1.51")	35H8 (1.37")
VS6DW63FG7	G3/4"	100 (3.94")	63 (2.48")	100 (3.94")	10,5 (0.41")	95 (3.74")	133 (5.23")	8 (0.31")	28.3 (1.11")	25H8 (0.98")
VS6DW63FG15	G3/4"	100 (3.94")	63 (2.48")	100 (3.94")	10,5 (0.41")	95 (3.74")	133 (5.23")	8 (0.31")	28.3 (1.11")	25H8 (0.98")
VS6DW85FG28	G3/4"	138 (5.43")	85 (3.34")	142 (5.60")	10,5 (0.41")	140 (5.51")	180 (7.10")	10 (0.39")	38.3 (1.51")	35H8 (1.37")
VS6DW85FG46	G3/4"	138 (5.43")	85 (3.34")	142 (5.60")	10,5 (0.41")	140 (5.51")	180 (7.10")	10 (0.39")	38.3 (1.51")	35H8 (1.37")
VS6DW110FG64	G3/4"	163 (6.42")	110 (4.33")	170 (6.70")	13 (0.51")	200 (7.87")	240 (9.45")	12 (0.47")	45.3 (1.78")	42H8 (1.65")
VS6DW110FG84	G3/4"	163 (6.42")	110 (4.33")	170 (6.70")	13 (0.51")	200 (7.87")	240 (9.45")	12 (0.47")	45.3 (1.78")	42H8 (1.65")
VS8DW85FG7	G1"	138 (5.43")	85 (3.34")	142 (5.60")	10,5 (0.41")	140 (5.51")	180 (7.10")	10 (0.39")	38.3 (1.51")	35H8 (1.37")
VS8DW85FG14	G1"	138 (5.43")	85 (3.34")	142 (5.60")	10,5 (0.41")	140 (5.51")	180 (7.10")	10 (0.39")	38.3 (1.51")	35H8 (1.37")
VS8DW110FG30	G1"	163 (6.42")	110 (4.33")	170 (6.70")	13 (0.51")	200 (7.87")	240 (9.45")	12 (0.47")	45.3 (1.78")	42H8 (1.65")
VS8DW110FG45	G1"	163 (6.42")	110 (4.33")	170 (6.70")	13 (0.51")	200 (7.87")	240 (9.45")	12 (0.47")	45.3 (1.78")	42H8 (1.65")
VS8DW110FG64	G1"	163 (6.42")	110 (4.33")	170 (6.70")	13 (0.51")	200 (7.87")	240 (9.45")	12 (0.47")	45.3 (1.78")	42H8 (1.65")
VS10DW85FG7	G 1 1/4"	138 (5.43")	85 (3.34")	142 (5.60")	10,5 (0.41")	140 (5.51")	180 (7.10")	10 (0.39")	38.3 (1.51")	35H8 (1.37")
VS10DW110FG16	G 1 1/4"	163 (6.42")	110 (4.33")	170 (6.70")	13 (0.51")	200 (7.87")	240 (9.45")	12 (0.47")	45.3 (1.78")	42H8 (1.65")
VS10DW110FG23	G 1 1/4"	163 (6.42")	110 (4.33")	170 (6.70")	13 (0.51")	200 (7.87")	240 (9.45")	12 (0.47")	45.3 (1.78")	42H8 (1.65")

DIMENSIONS OUTPUT SHAFT FOR WORM GEARS (OPTIONAL)

SINGLE OUTPUT SHAFT

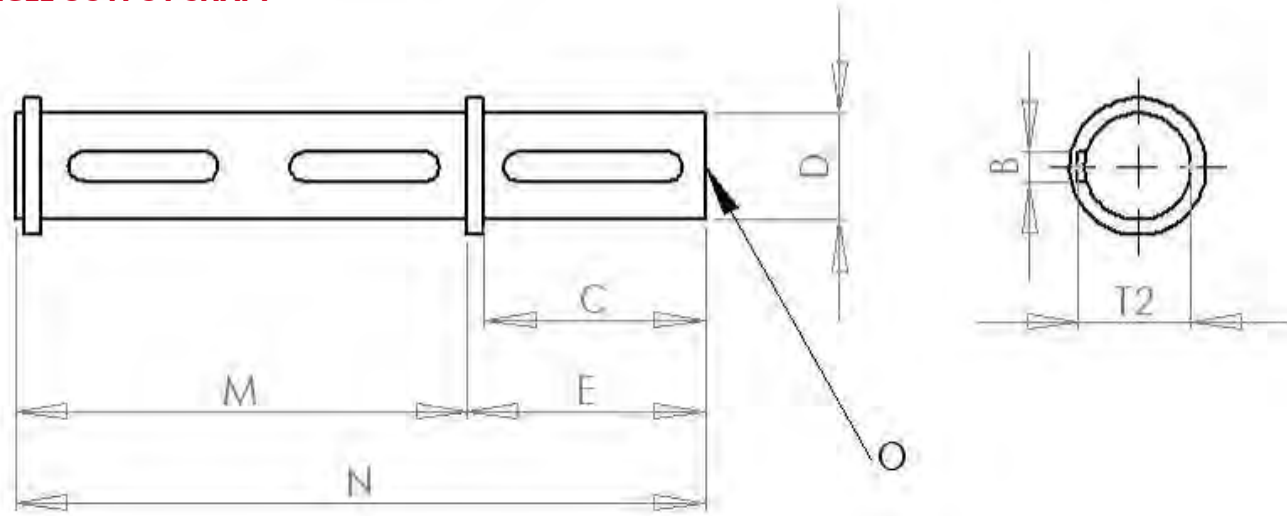

Size gearbox	B	C	D	E	M	N	O	T2
063	8 (0.31")	60 (2.36")	25 (0.98")	63 (2.48")	127 (5.00")	190 (7.48")	M8x20 (0.79")	28.3 (1.11")
085	10 (0.39")	60 (2.36")	35 (1.38")	73.5 (2.89")	140 (5.51")	214 (8.42")	M10x23 (0.90")	38.3 (1.51")
110	12 (0.47")	75 (2.95")	42 (1.65")	96.5 (3.80")	163.5 (6.43")	260 (10.23")	M12x32 (1.26")	45.3 (1.78")

DOUBLE OUTPUT SHAFT

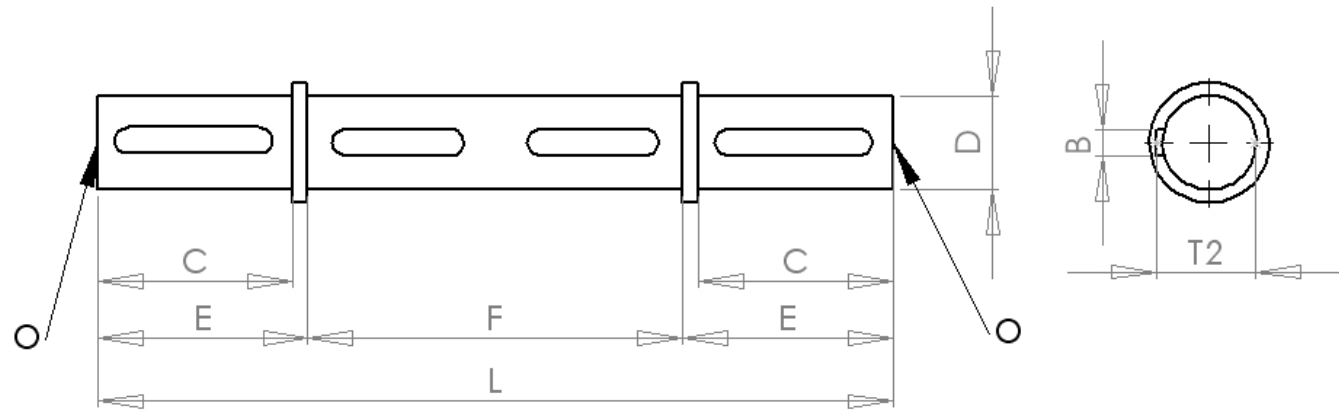

Size gearbox	B	C	D	E	F	L	O	T2
063	8 (0.31")	60 (2.36")	25 (0.98")	63 (2.48")	120 (4.72")	246,4 (9.70")	M8x20 (0.79")	28.3 (1.11")
085	10 (0.39")	60 (2.36")	35 (1.38")	73.5 (2.89")	135 (5.31")	282 (11.10")	M10x23 (0.90")	38.3 (1.51")
110	12 (0.47")	75 (2.95")	42 (1.65")	96.5 (3.80")	155 (6.10")	348 (13.70")	M12x32 (1.26")	45.3 (1.78")

PERFORMANCES GLOBE VS4C AIR MOTOR WORM GEARBOX

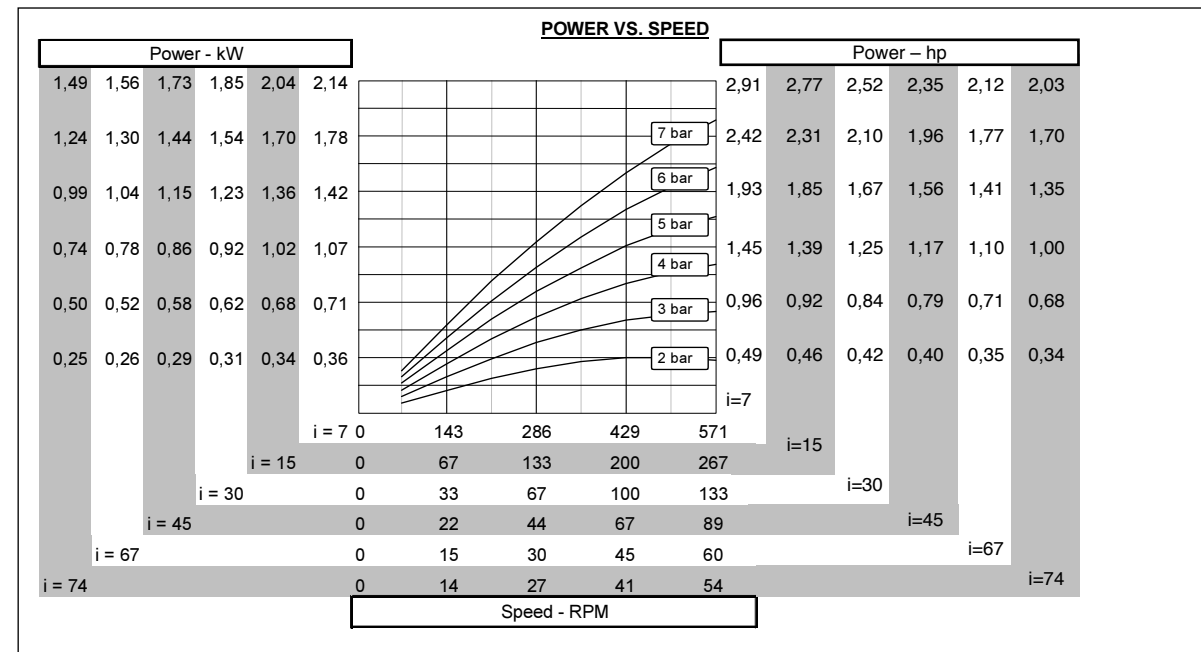
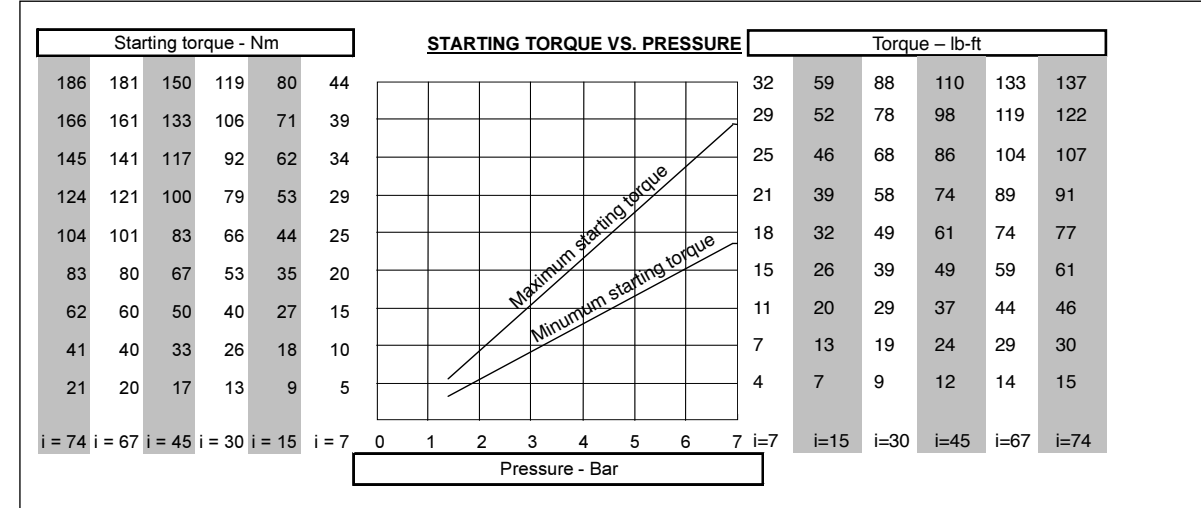
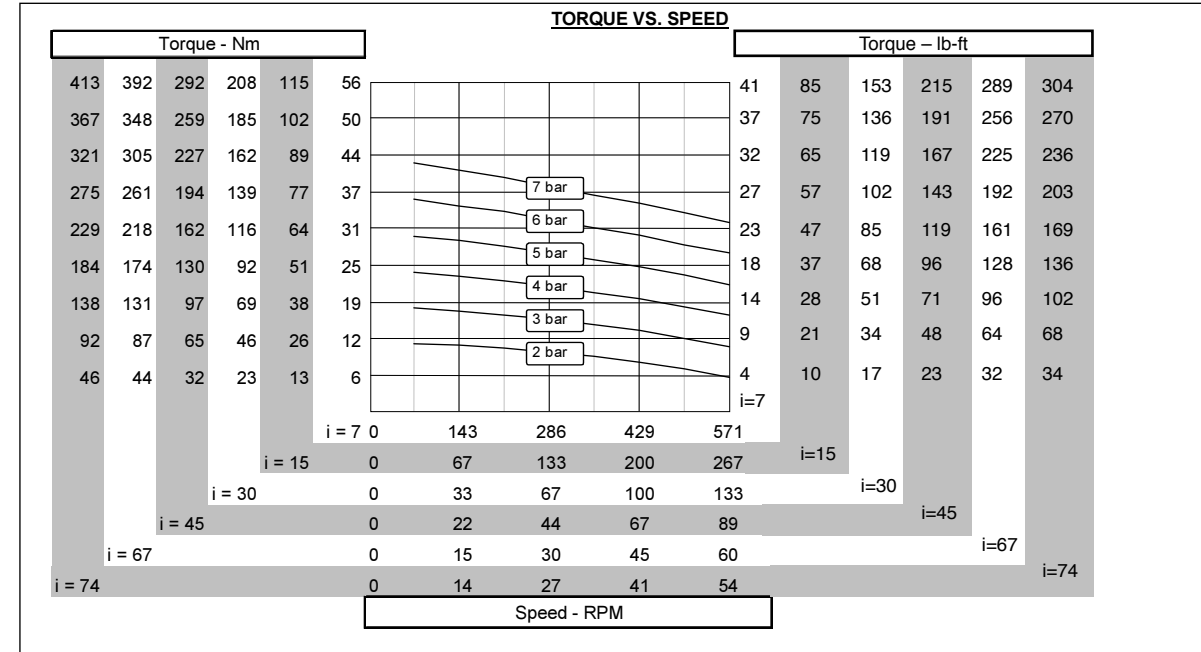

PERFORMANCES GLOBE VS6C AIR MOTOR WORM GEARBOX

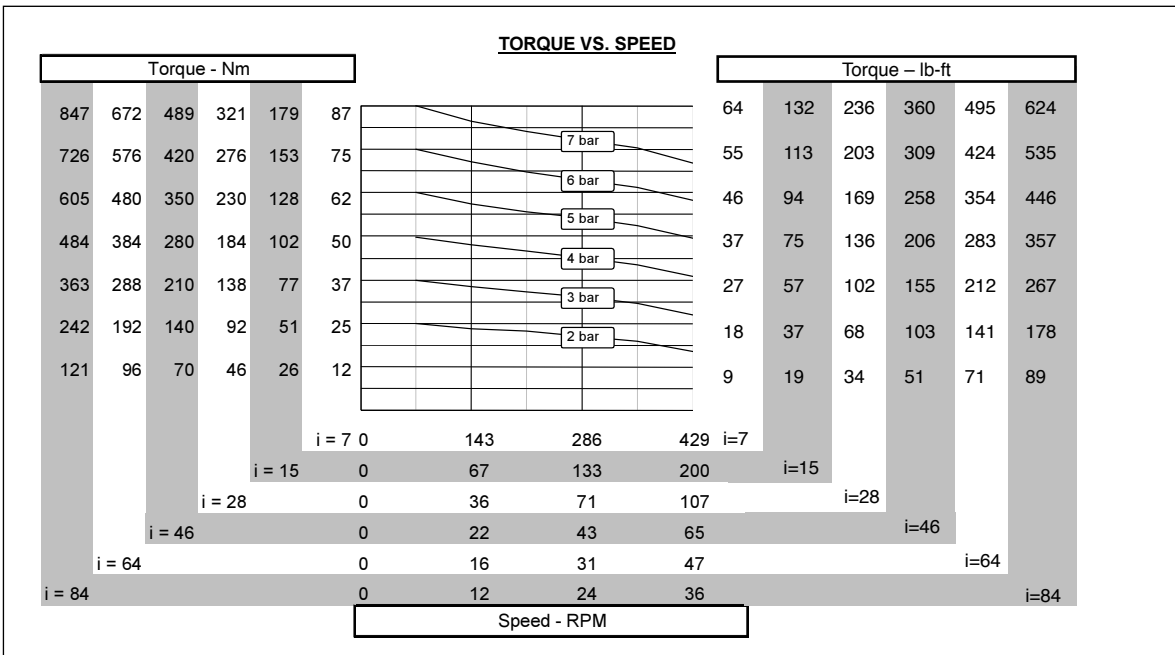

PERFORMANCES GLOBE VS8C AIR MOTOR WORM GEARBOX

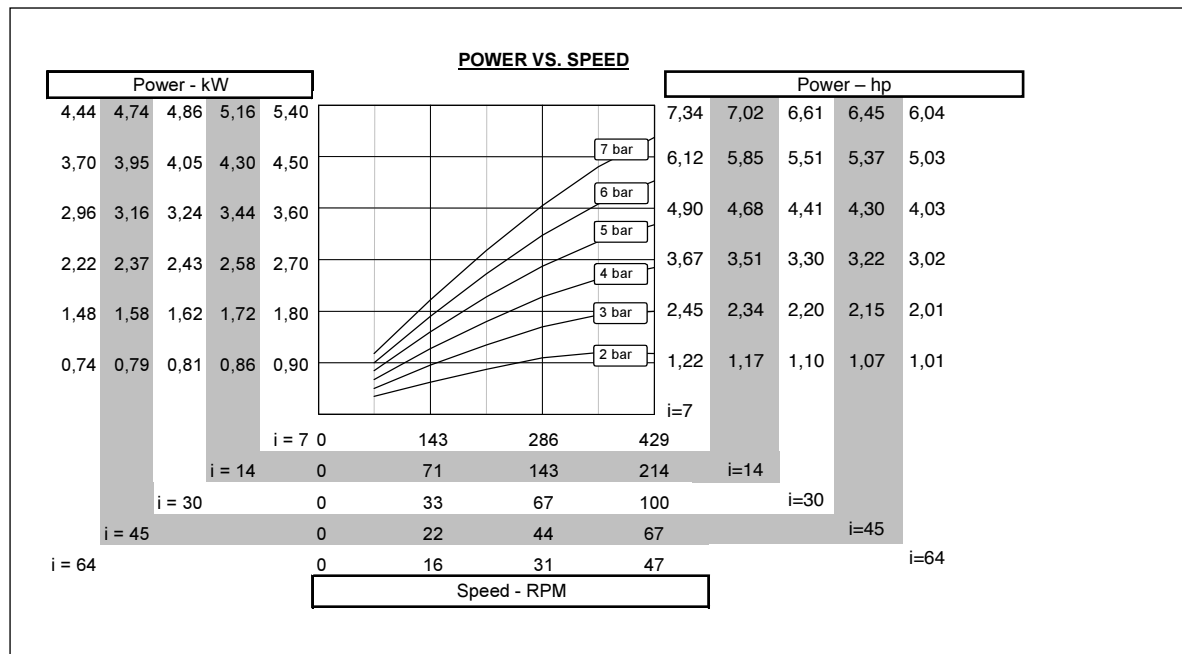
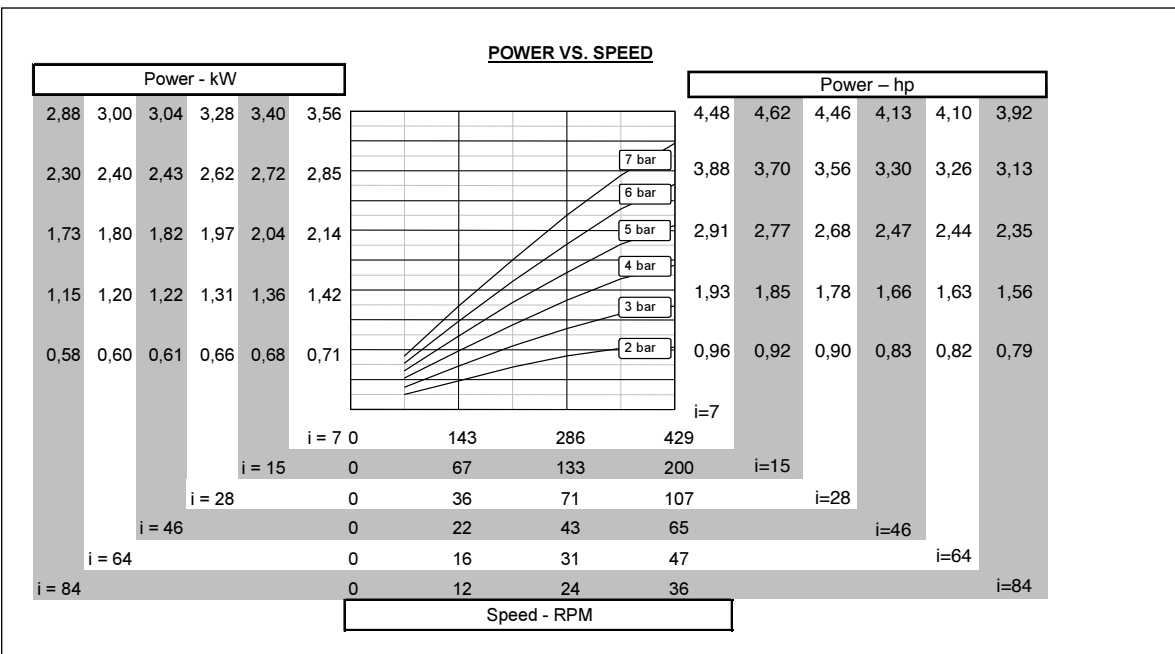
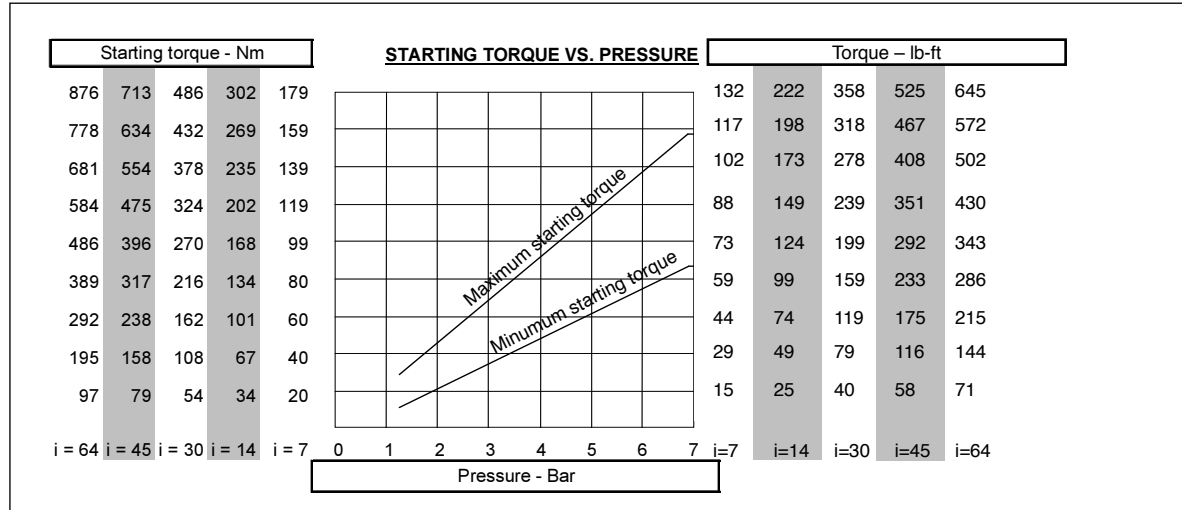
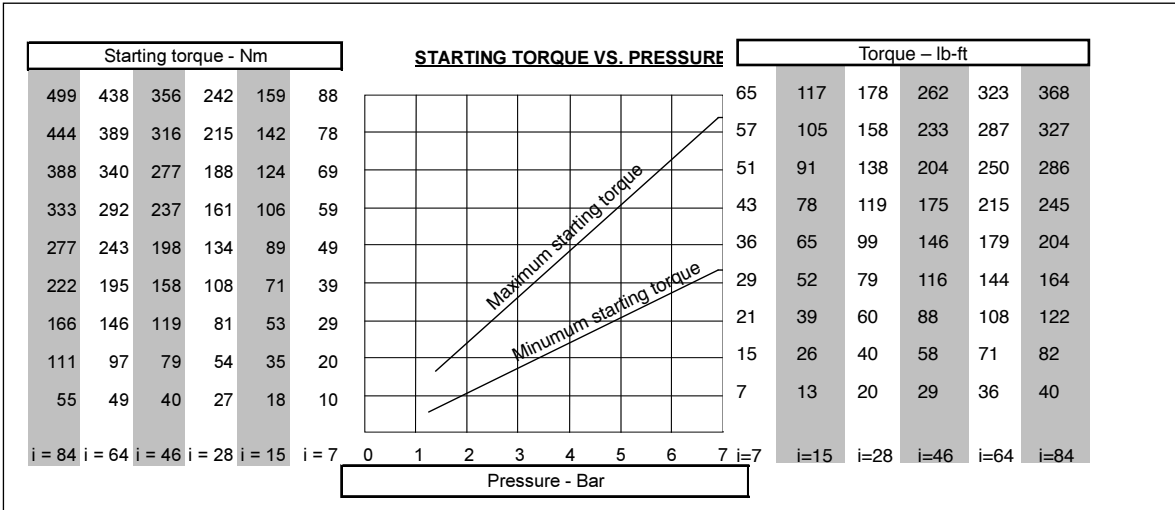
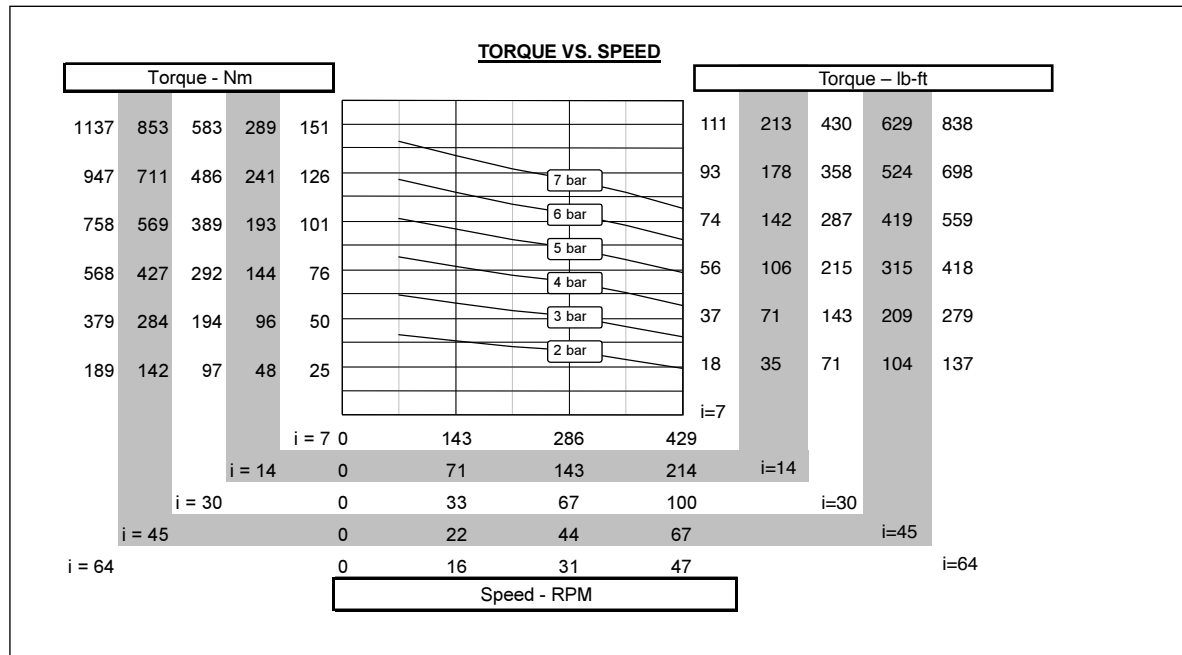

PERFORMANCES GLOBE VS10C AIR MOTOR WORM GEARBOX

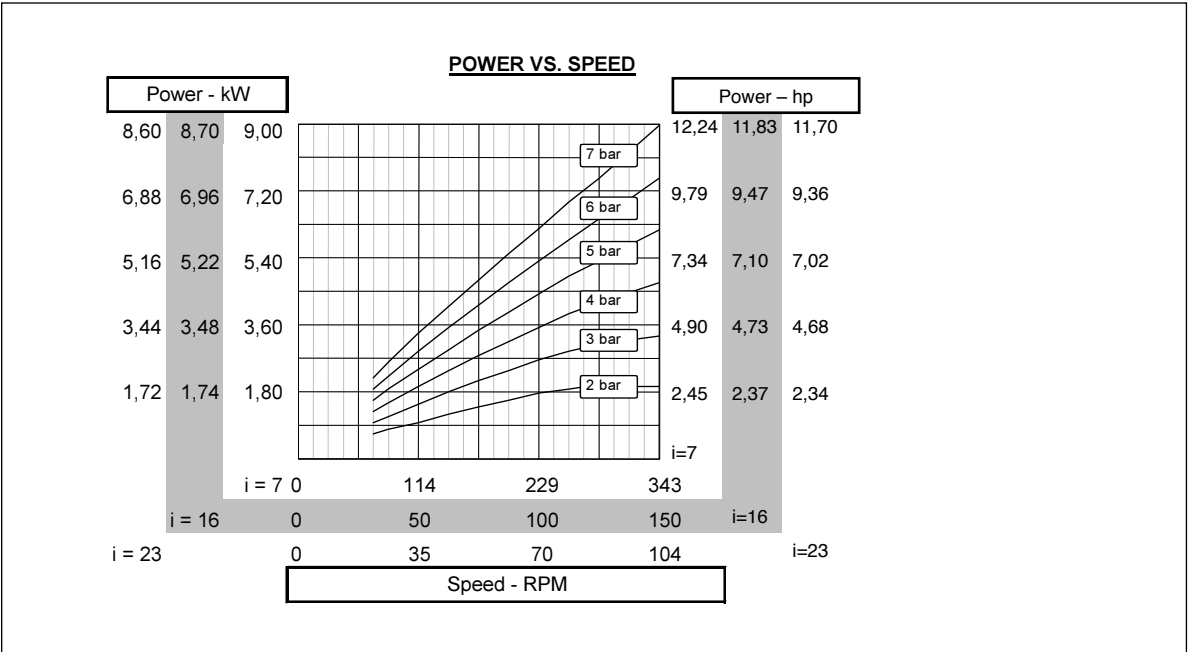
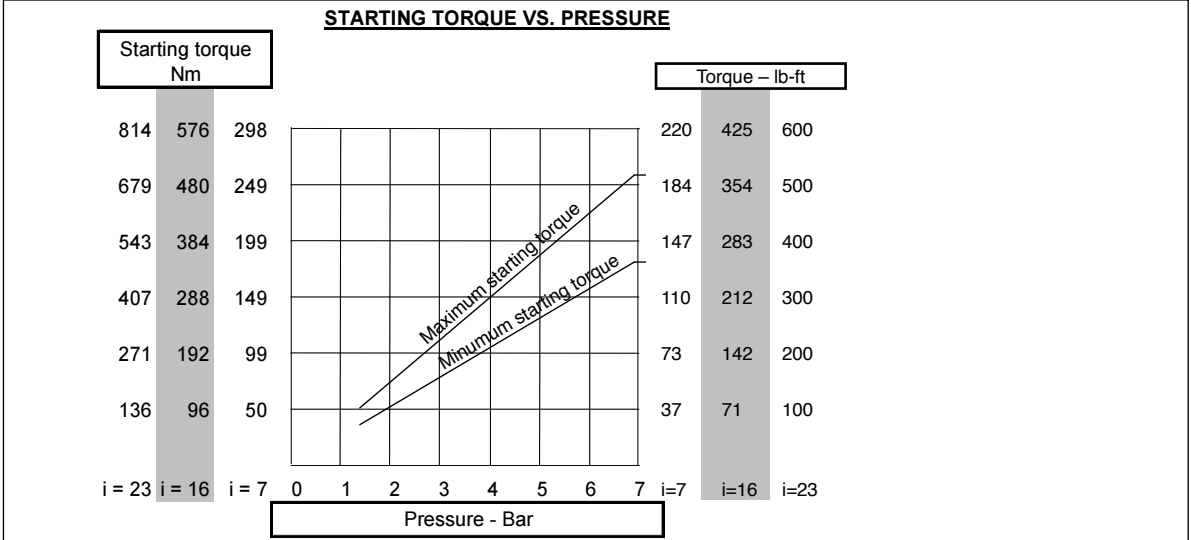
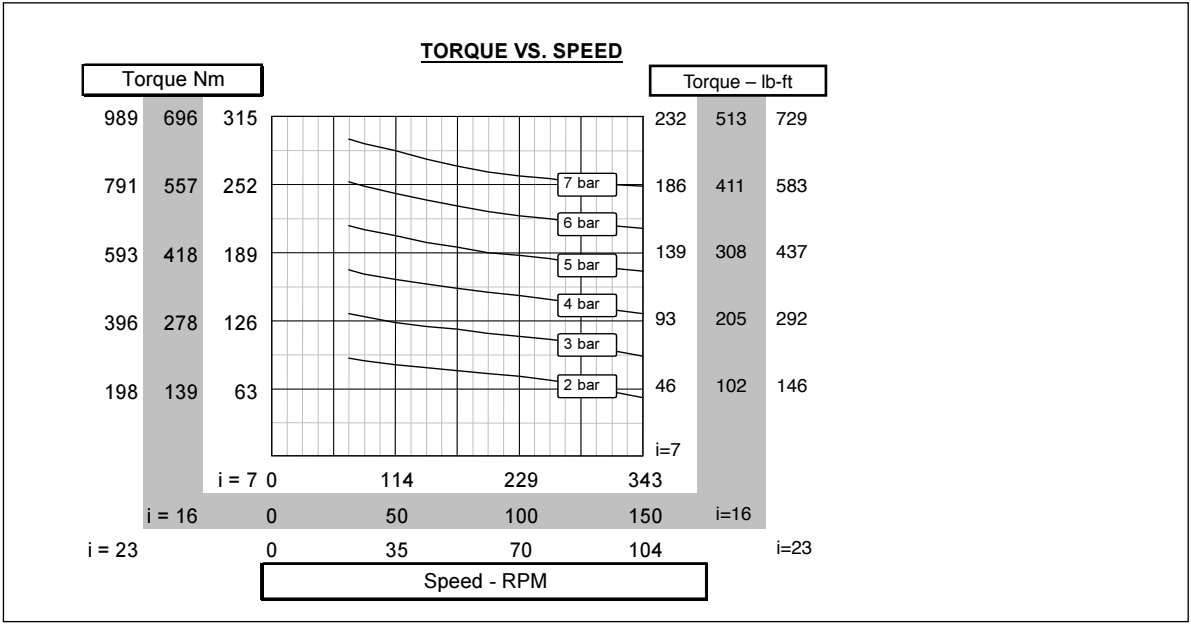

PERFORMANCE GLOBE VANE AIR MOTORS WITH COAXIAL GEARS

Ordering code flange model	Ordering code foot model	i	Power* (kW / hp)	Max. rpm**	Nominal torque (Nm / lb-ft)	Min. starting torque (Nm / lb-ft)	Weight flange model (Kg / lb)	Weight foot model (Kg / lb)
GLOBE V4 + coaxial gear								
VS4DA402FG10	VS4DA402BG10	10	1.5kW / 2.0hp	300	48Nm / 35lb-ft	42Nm / 31lb-ft	15Kg / 33lb	15Kg / 33lb
VS4DA402FG22	VS4DA402BG22	22	1.5kW / 2.0hp	136	106Nm / 78lb-ft	92Nm / 68lb-ft	15Kg / 33lb	15Kg / 33lb
VS4DC402FG29	VS4DA402BG29	29	1.5kW / 2.0hp	103	139Nm / 102lb-ft	122Nm / 90lb-ft	15Kg / 33lb	15Kg / 33lb
VS4DC402FG38	VS4DA402BG38	38	1.5kW / 2.0hp	79	182Nm / 134lb-ft	160Nm / 118lb-ft	15Kg / 33lb	15Kg / 33lb
VS4DC403FG51	VS4DA403BG51	51	1.5kW / 2.0hp	59	245Nm / 181lb-ft	214Nm / 158lb-ft	15Kg / 33lb	15Kg / 33lb
GLOBE V6 + coaxial gear								
VS6DA402FG10	VS6DA402BG10	10	2.9kW / 3.9hp	300	92Nm / 68lb-ft	75Nm / 55lb-ft	21Kg / 46lb	21Kg / 46lb
VS6DA402FG22	VS6DA402BG22	22	2.9kW / 3.9hp	136	202Nm / 149lb-ft	165Nm / 122lb-ft	21Kg / 46lb	21Kg / 46lb
VS6DA602FG29	VS6DA602BG29	29	2.9kW / 3.9hp	103	267Nm / 197lb-ft	218Nm / 161lb-ft	34Kg / 75lb	33Kg / 72,6lb
VS6DA602FG40	VS6DA602BG40	40	2.9kW / 3.9hp	75	368Nm / 271lb-ft	300Nm / 221lb-ft	34Kg / 75lb	33Kg / 72,6lb
VS6DA603FG55	VS6DA603BG55	55	2.9kW / 3.9hp	60	460Nm / 339lb-ft	375Nm / 276lb-ft	50Kg / 110lb	48Kg / 105,6lb
GLOBE V8 + coaxial gear								
VS8DA602FG10	VS8DA602BG10	10	4.5kW / 6.1hp	300	145Nm / 107lb-ft	150Nm / 111lb-ft	23Kg / 50,6lb	22Kg / 48,4lb
VS8DA602FG20	VS8DA602BG20	20	4.5kW / 6.1hp	150	290Nm / 214lb-ft	300Nm / 221lb-ft	36Kg / 79,2lb	34Kg / 74,8lb
VS8DA602FG30	VS8DA602BG30	30	4.5kW / 6.1hp	100	435Nm / 321lb-ft	450nm / 332lb-ft	50kg / 110lb	48Kg / 105,6lb
GLOBE V8 + planetary gear								
VS8EPFG300FG42	VS8EPFG300BG42	42	4.5kW / 6.1hp	71	609Nm / 449lb-ft	630Nm / 464lb-ft	39Kg / 85,8lb	44Kg / 96,8lb
VS8EPFG300FG52	VS8EPFG300BG52	52	4.5kW / 6.1hp	55	754Nm / 556lb-ft	720Nm / 531lb-ft	39Kg / 85,8lb	44Kg / 96,8lb
GLOBE V10 + planetary gear								
VS10EPFG301FG20	VS10EPFG301BG20	20	8.3kW / 11.3hp	120	660Nm / 486lb-ft	600Nm / 442lb-ft	52Kg / 114,4lb	57Kg / 125,4lb
VS10EPFG301FG31	VS10EPFG301BG31	31	8.3kW / 11.3hp	77	1023Nm / 754lb-ft	930Nm / 685lb-ft	52Kg / 114,4lb	57Kg / 125,4lb
VS10EPFG301FG42	VS10EPFG301BG42	42	8.3kW / 11.3hp	57	1386Nm / 1021lb-ft	1260Nm / 925lb-ft	52Kg / 114,4lb	57Kg / 125,4lb
VS10EPFG301FG52	VS10EPFG301BG52	52	8.3kW / 11.3hp	46	1716Nm / 1265lb-ft	1560Nm / 1150lb-ft	52Kg / 114,4lb	57Kg / 125,4lb

* Power and nominal torque at 6 bar and motor input speed of 3000 rpm (V4, V6, V8) and 2400 rpm (V10).

** In applications where the motor input speed exceeds 2200 rpm, only intermittent use is tolerated.

DIMENSIONS GLOBE VANE AIR MOTORS WITH COAXIAL GEARS - FLANGE MODEL

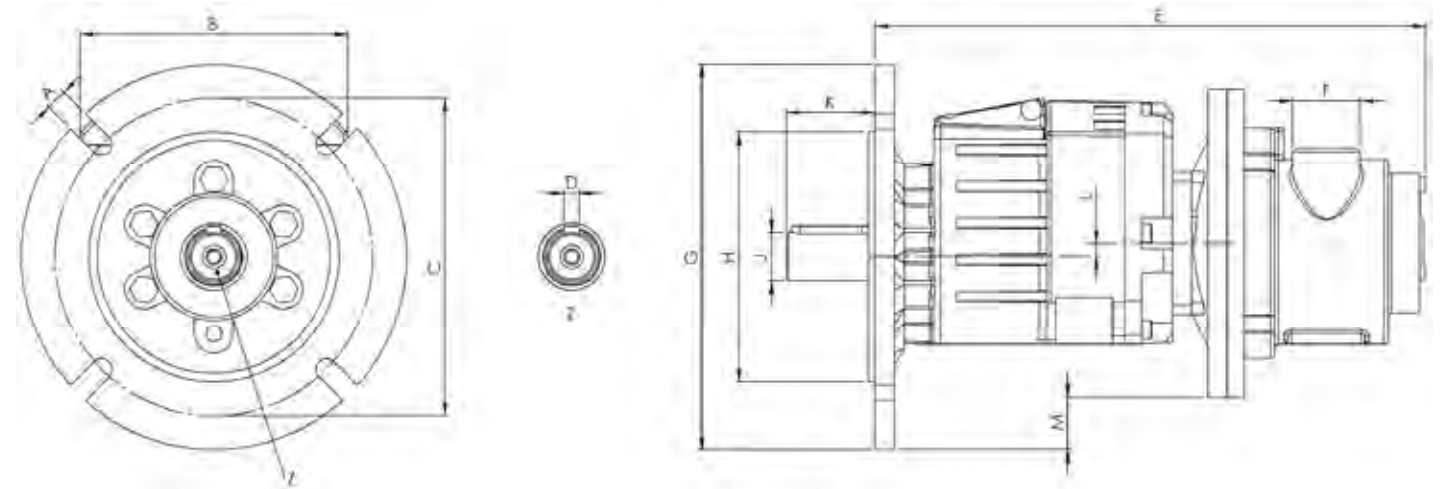

Ordering code	A	B	C	D	E	F
VS4DA402FG10	11 (0.43")	139 (5.47")	Ø165 (6.49")	8 (0.31")	283 (9.37")	G1/2"
VS4DA402FG22	11 (0.43")	139 (5.47")	Ø165 (6.49")	8 (0.31")	283 (9.37")	G1/2"
VS4DA402FG29	11 (0.43")	139 (5.47")	Ø165 (6.49")	8 (0.31")	283 (9.37")	G1/2"
VS4DA402FG38	11 (0.43")	139 (5.47")	Ø165 (6.49")	8 (0.31")	283 (9.37")	G1/2"
VS4DA403FG51	11 (0.43")	139 (5.47")	Ø165 (6.49")	8 (0.31")	288 (11.33")	G1/2"
VS6DA402FG10	Ø14 (0.55")	139 (5.47")	Ø215 (8.46")	8 (0.31")	337 (13.26")	G3/4"
VS6DA402FG22	Ø14 (0.55")	139 (5.47")	Ø215 (8.46")	8 (0.31")	337 (13.26")	G3/4"
VS6DA602FG29	Ø14 (0.55")	202 (7.95")	Ø215 (8.46")	8 (0.31")	401 (15.78")	G3/4"
VS6DA602FG40	Ø14 (0.55")	202 (7.95")	Ø215 (8.46")	8 (0.31")	401 (15.78")	G3/4"
VS6DA603FG55	Ø14 (0.55")	202 (7.95")	Ø215 (8.46")	8 (0.31")	408 (16.06")	G3/4"
VS8DA602FG10	Ø14 (0.55")	202 (7.95")	Ø164 (6.45")	8 (0.31")	404 (15.90")	G1"
VS8DA602FG20	Ø14 (0.55")	202 (7.95")	Ø164 (6.45")	8 (0.31")	404 (15.90")	G1"
VS8DA602FG30	Ø14 (0.55")	202 (7.95")	Ø164 (6.45")	8 (0.31")	404 (15.90")	G1"

Ordering code	G	H	J	K	L	M
VS4DA402FG10	Ø200 (7.87")	Ø130 (5.12")	Ø25h6 (0.98")	46 (1.81")	7 (0.27")	27 (1.06")
VS4DA402FG22	Ø200 (7.87")	Ø130 (5.12")	Ø25h6 (0.98")	46 (1.81")	7 (0.27")	27 (1.06")
VS4DA402FG29	Ø200 (7.87")	Ø130 (5.12")	Ø25h6 (0.98")	46 (1.81")	7 (0.27")	27 (1.06")
VS4DA402FG38	Ø200 (7.87")	Ø130 (5.12")	Ø25h6 (0.98")	46 (1.81")	7 (0.27")	27 (1.06")
VS4DA403FG51	Ø200 (7.87")	Ø130 (5.12")	Ø25h6 (0.98")	46 (1.81")	3 (0.12")	23 (0.90")
VS6DA402FG10	Ø250 (9.84")	Ø180 (7.08")	Ø25h6 (0.98")	46 (1.81")	7 (0.27")	32 (1.26")
VS6DA402FG22	Ø250 (9.84")	Ø180 (7.08")	Ø25h6 (0.98")	46 (1.81")	7 (0.27")	32 (1.26")
VS6DA602FG29	Ø250 (9.84")	Ø180 (7.08")	Ø30h6 (1.18")	58 (2.28")	22 (0.86")	47 (1.85")
VS6DA602FG40	Ø250 (9.84")	Ø180 (7.08")	Ø30h6 (1.18")	58 (2.28")	22 (0.86")	47 (1.85")
VS6DA603FG55	Ø250 (9.84")	Ø180 (7.08")	Ø30h6 (1.18")	58 (2.28")	16 (0.63")	41 (1.61")
VS8DA602FG10	Ø200 (7.87")	Ø128 (5.04")	Ø30h6 (1.18")	54 (2.12")	22 (0.86")	22 (0.86")
VS8DA602FG20	Ø200 (7.87")	Ø128 (5.04")	Ø30h6 (1.18")	54 (2.12")	22 (0.86")	22 (0.86")
VS8DA602FG30	Ø200 (7.87")	Ø128 (5.04")	Ø30h6 (1.18")	54 (2.12")	22 (0.86")	22 (0.86")

DIMENSIONS GLOBE VANE AIR MOTORS WITH PLANETARY GEARS - FLANGE MODEL

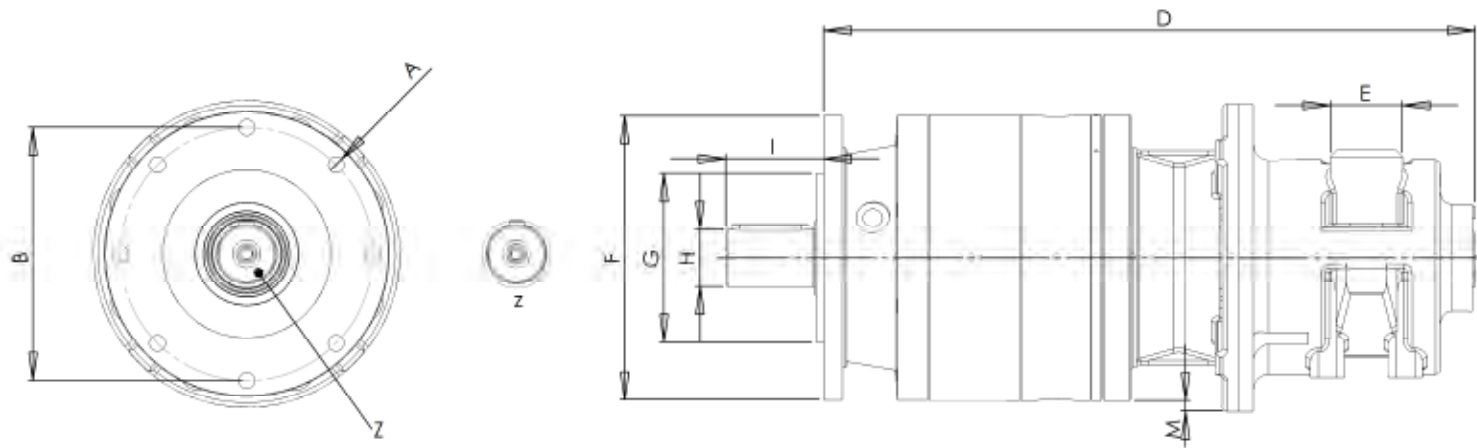

Ordering code	A	B	C	D	E	F	G	H	I
VS8EPFG300FG42	Ø10,5 (0.41")	Ø165 (6.49")	10 (0.39")	426 (16.77")	G1"	Ø185 (7.28")	Ø110 (4.33")	Ø38h6 (1.49")	64 (2.52")
VS8EPFG300FG52	Ø10,5 (0.41")	Ø165 (6.49")	10 (0.39")	426 (16.77")	G1"	Ø185 (7.28")	Ø110 (4.33")	Ø38h6 (1.49")	64 (2.52")
VS10EPFG301FG20	Ø10,5 (0.41")	Ø165 (6.49")	10 (0.39")	465 (18.30")	G1¼"	Ø250 (9.84")	Ø110 (4.33")	Ø38h6 (1.49")	64 (2.52")
VS10EPFG301FG31	Ø10,5 (0.41")	Ø165 (6.49")	10 (0.39")	465 (18.30")	G1¼"	Ø250 (9.84")	Ø110 (4.33")	Ø38h6 (1.49")	64 (2.52")
VS10EPFG301FG42	Ø10,5 (0.41")	Ø165 (6.49")	10 (0.39")	465 (18.30")	G1¼"	Ø250 (9.84")	Ø110 (4.33")	Ø38h6 (1.49")	64 (2.52")
VS10EPFG301FG52	Ø10,5 (0.41")	Ø165 (6.49")	10 (0.39")	465 (18.30")	G1¼"	Ø250 (9.84")	Ø110 (4.33")	Ø38h6 (1.49")	64 (2.52")

DIMENSIONS GLOBE VANE AIR MOTORS WITH COAXIAL GEARS - FOOT MODEL

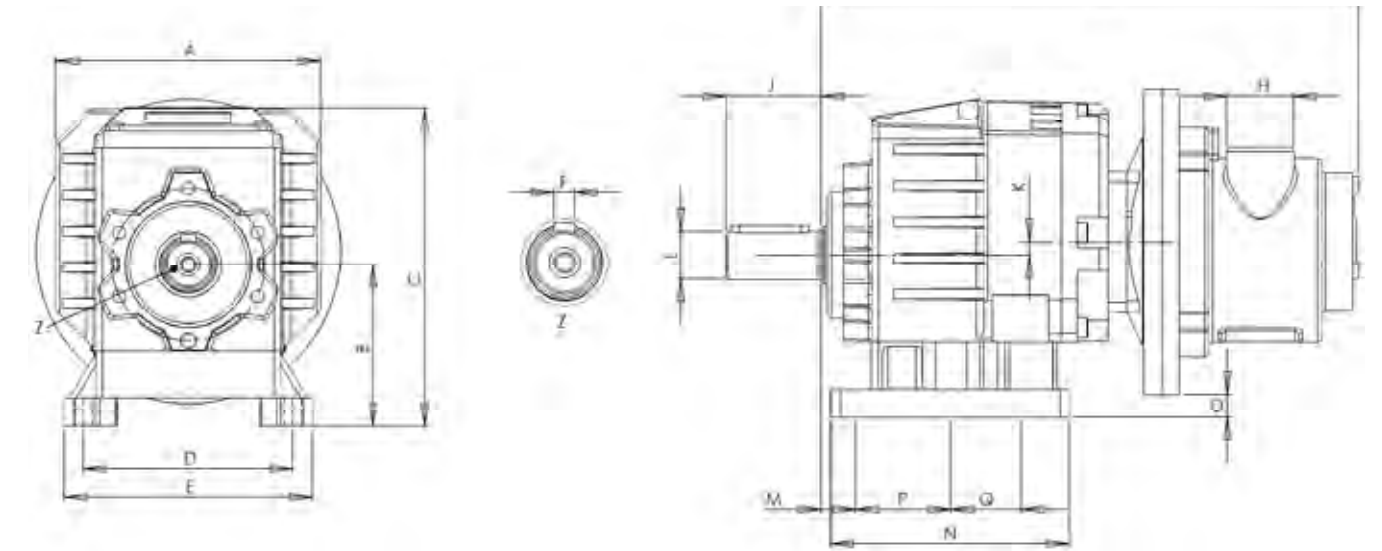

Motor + gear size	A	B	C	D	E	F	G	H
VS4DA402BG10	139 (5.47")	85 (3.34")	167 (6.57")	110 (4.33")	130 (5.12")	8 (0.31")	282 (11.10")	G1/2"
VS4DA402BG22	139 (5.47")	85 (3.34")	167 (6.57")	110 (4.33")	130 (5.12")	8 (0.31")	282 (11.10")	G1/2"
VS4DA402BG29	139 (5.47")	85 (3.34")	167 (6.57")	110 (4.33")	130 (5.12")	8 (0.31")	282 (11.10")	G1/2"
VS4DA402BG38	139 (5.47")	85 (3.34")	167 (6.57")	110 (4.33")	130 (5.12")	8 (0.31")	282 (11.10")	G1/2"
VS4DA403BG51	139 (5.47")	85 (3.34")	167 (6.57")	110 (4.33")	130 (5.12")	8 (0.31")	281 (11.06")	G1/2"
VS6DA402BG10	139 (5.47")	85 (3.34")	167 (6.57")	110 (4.33")	130 (5.12")	8 (0.31")	333 (13.11")	G3/4"
VS6DA402BG22	139 (5.47")	85 (3.34")	167 (6.57")	110 (4.33")	130 (5.12")	8 (0.31")	333 (13.11")	G3/4"
VS6DA602BG29	202 (7.95")	130 (5.12")	234 (9.21")	180 (7.08")	216 (8.50")	8 (0.31")	399 (15.71")	G3/4"
VS6DA602BG40	202 (7.95")	130 (5.12")	234 (9.21")	180 (7.08")	216 (8.50")	8 (0.31")	399 (15.71")	G3/4"
VS6DA603BG55	202 (7.95")	130 (5.12")	234 (9.21")	180 (7.08")	216 (8.50")	8 (0.31")	408 (16.06")	G3/4"
VS8DA602BG10	202 (7.95")	130 (5.12")	234 (9.21")	180 (7.08")	216 (8.50")	8 (0.31")	402 (15.83")	G1"
VS8DA602BG20	202 (7.95")	130 (5.12")	234 (9.21")	180 (7.08")	216 (8.50")	8 (0.31")	402 (15.83")	G1"
VS8DA602BG30	202 (7.95")	130 (5.12")	234 (9.21")	180 (7.08")	216 (8.50")	8 (0.31")	402 (15.83")	G1"

Motor + gear size	J	K	L	M	N	O	P	Q
VS4DA402BG10	53 (2.08")	7 (0.27")	Ø25h6 (0.98")	18 (0.71")	125 (4.92")	12 (0.47")	50 (1.97")	37 (1.45")
VS4DA402BG22	53 (2.08")	7 (0.27")	Ø25h6 (0.98")	18 (0.71")	125 (4.92")	12 (0.47")	50 (1.97")	37 (1.45")
VS4DA402BG29	53 (2.08")	7 (0.27")	Ø25h6 (0.98")	18 (0.71")	125 (4.92")	12 (0.47")	50 (1.97")	37 (1.45")
VS4DA402BG38	53 (2.08")	7 (0.27")	Ø25h6 (0.98")	18 (0.71")	125 (4.92")	12 (0.47")	50 (1.97")	37 (1.45")
VS4DA403BG51	50 (1.97")	3 (0.12")	Ø25h6 (0.98")	18 (0.71")	125 (4.92")	15 (0.59")	50 (1.97")	50 (1.97")
VS6DA402BG10	50 (1.97")	7 (0.27")	Ø25h6 (0.98")	18 (0.71")	125 (4.92")	8 (0.31")	50 (1.97")	37 (1.45")
VS6DA402BG22	50 (1.97")	7 (0.27")	Ø25h6 (0.98")	18 (0.71")	125 (4.92")	8 (0.31")	50 (1.97")	37 (1.45")
VS6DA602BG29	60 (2.36")	22 (0.86")	Ø30h6 (1.18")	20 (0.78")	186 (7.32")	52 (2.04")	150 (5.90")	...
VS6DA602BG40	60 (2.36")	22 (0.86")	Ø30h6 (1.18")	20 (0.78")	186 (7.32")	52 (2.04")	150 (5.90")	...
VS6DA603BG55	60 (2.36")	16 (0.63")	Ø30h6 (1.18")	20 (0.78")	186 (7.32")	46 (1.81")	150 (5.90")	...
VS8DA602BG10	60 (2.36")	22 (0.86")	Ø30h6 (1.18")	20 (0.78")	186 (7.32")	52 (2.04")	150 (5.90")	...
VS8DA602BG20	60 (2.36")	22 (0.86")	Ø30h6 (1.18")	20 (0.78")	186 (7.32")	52 (2.04")	150 (5.90")	...
VS8DA602BG30	60 (2.36")	22 (0.86")	Ø30h6 (1.18")	20 (0.78")	186 (7.32")	52 (2.04")	150 (5.90")	...

DIMENSIONS GLOBE VANE AIR MOTORS WITH PLANETARY GEARS - FOOT MODEL

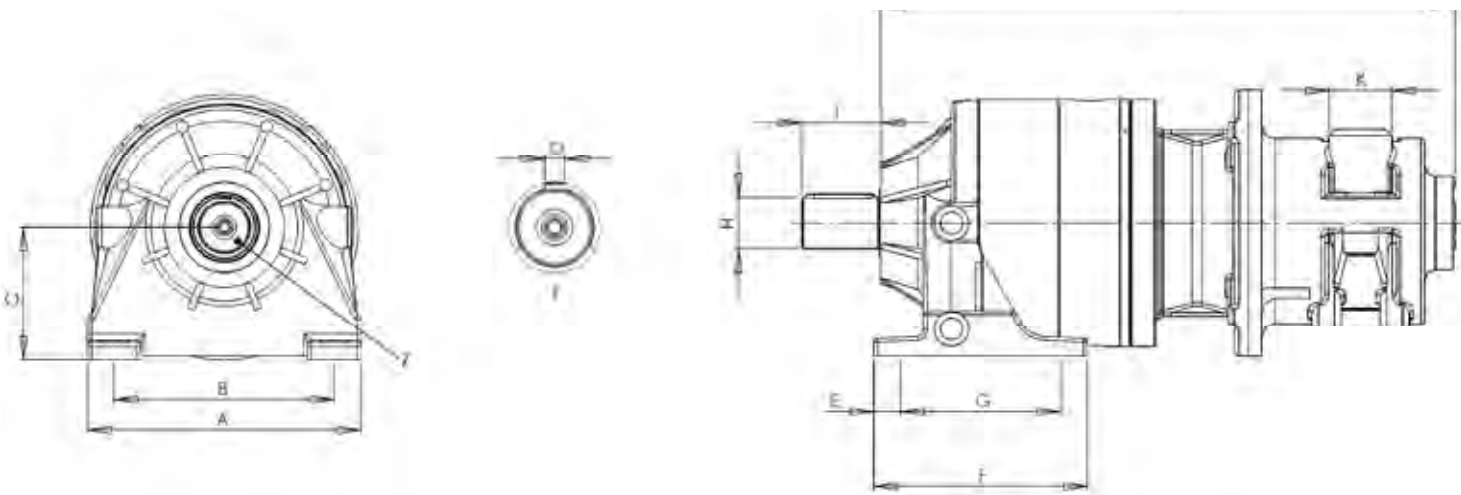

Motor + gear size	A	B	C	D	E	F	G	H	I	J	K
VS8EPFG300BG42	205 (8.07")	165 (6.49")	100 (3.93")	10 (0.39")	20	160	120	∅38h6	60	429	G1"
VS8EPFG300BG52	205 (8.07")	165 (6.49")	100 (3.93")	10 (0.39")	20	160	120	∅38h6	60	429	G1"
VS10EPFG301BG20	260 (10.23")	216 (8.50")	132 (5.19")	14 (0.55")	21	180	138	∅50h6	82	501	G1¼"
VS10EPFG301BG31	260 (10.23")	216 (8.50")	132 (5.19")	14 (0.55")	21	180	138	∅50h6	82	501	G1¼"
VS10EPFG301BG42	260 (10.23")	216 (8.50")	132 (5.19")	14 (0.55")	21	180	138	∅50h6	82	501	G1¼"
VS10EPFG301BG52	260 (10.23")	216 (8.50")	132 (5.19")	14 (0.55")	21	180	138	∅50h6	82	501	G1¼"

PERFORMANCES GLOBE VS4C AIR MOTOR WITH COAXIAL GEAR

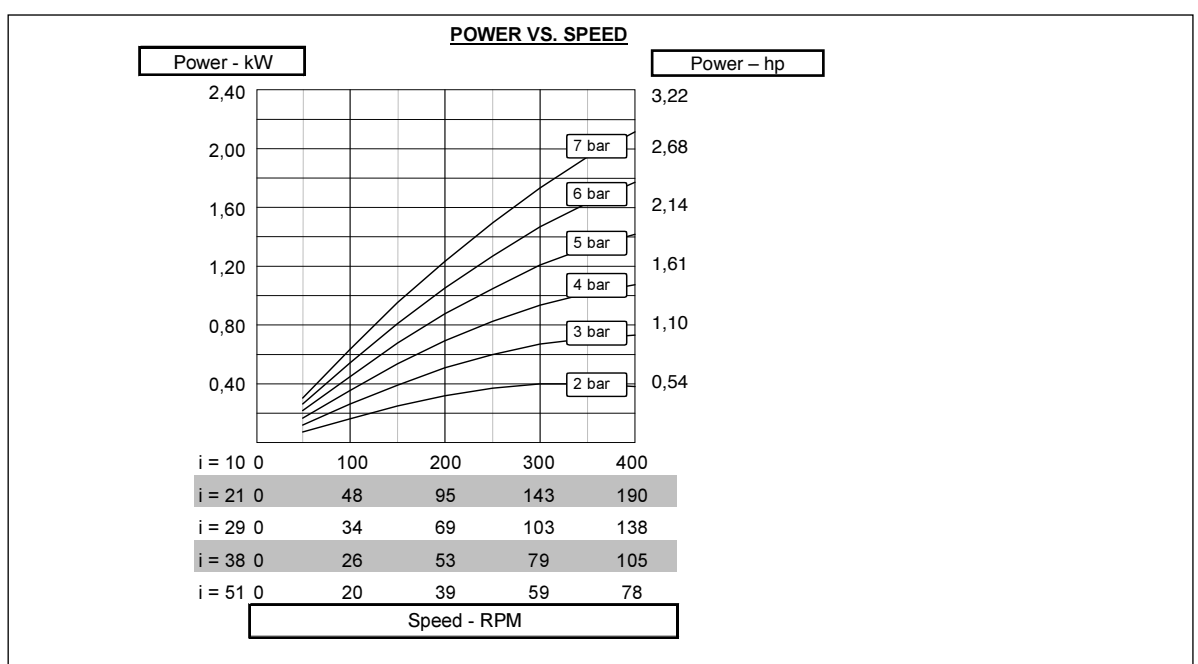
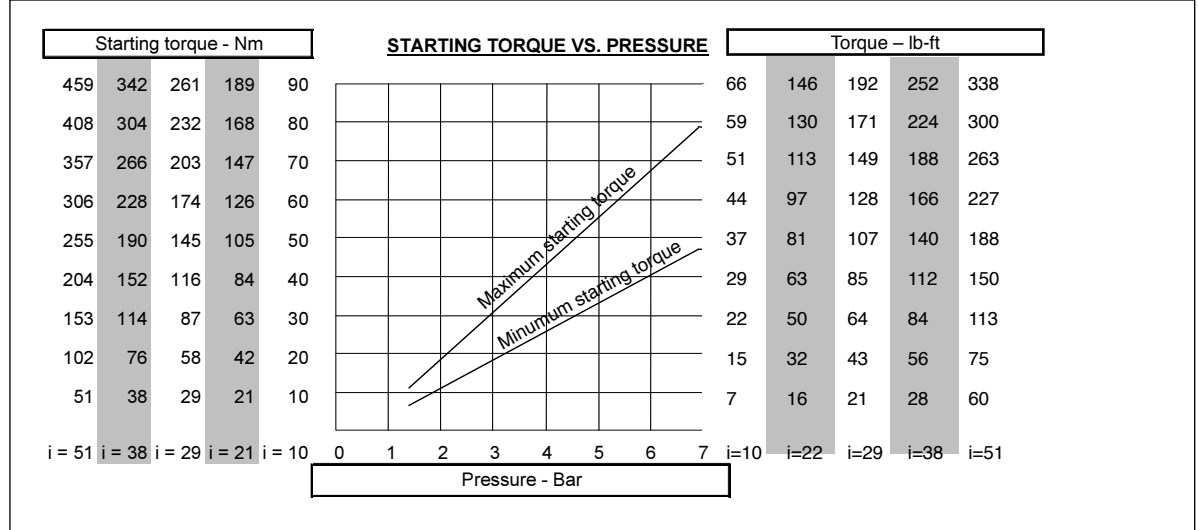
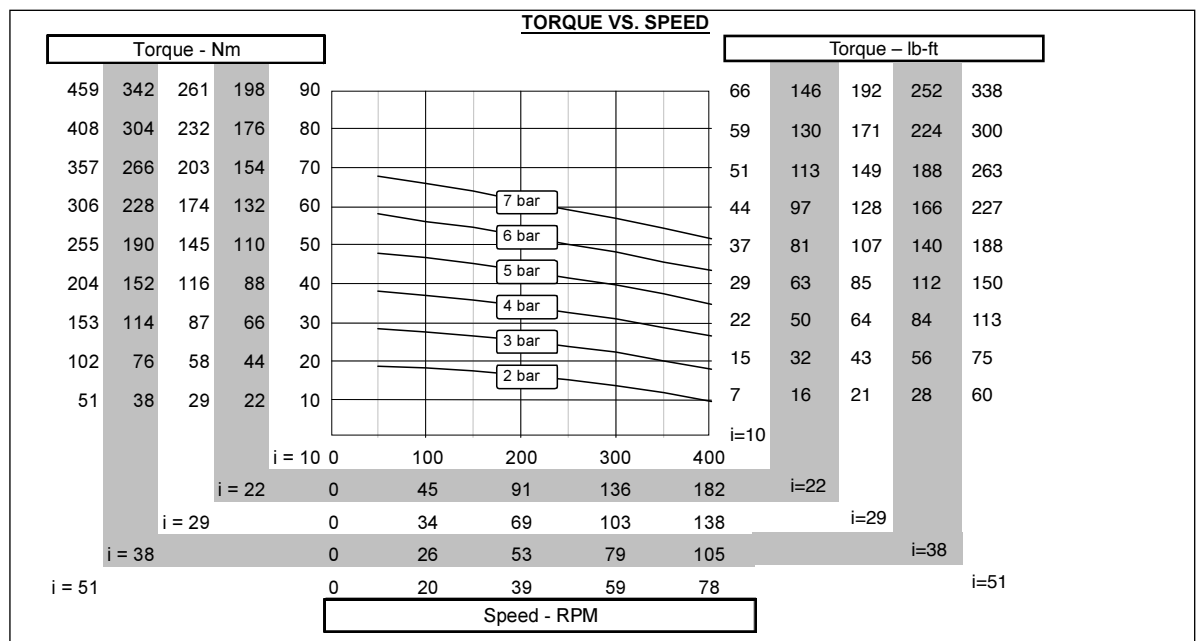

PERFORMANCES GLOBE VS6C AIR MOTOR WITH COAXIAL GEAR

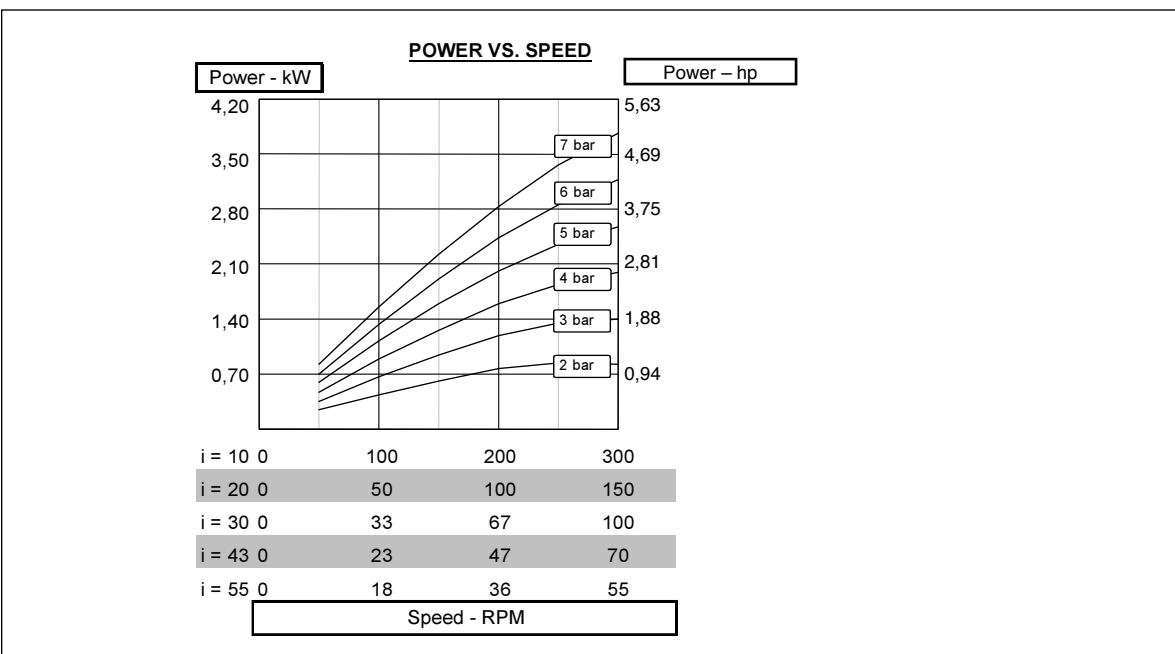
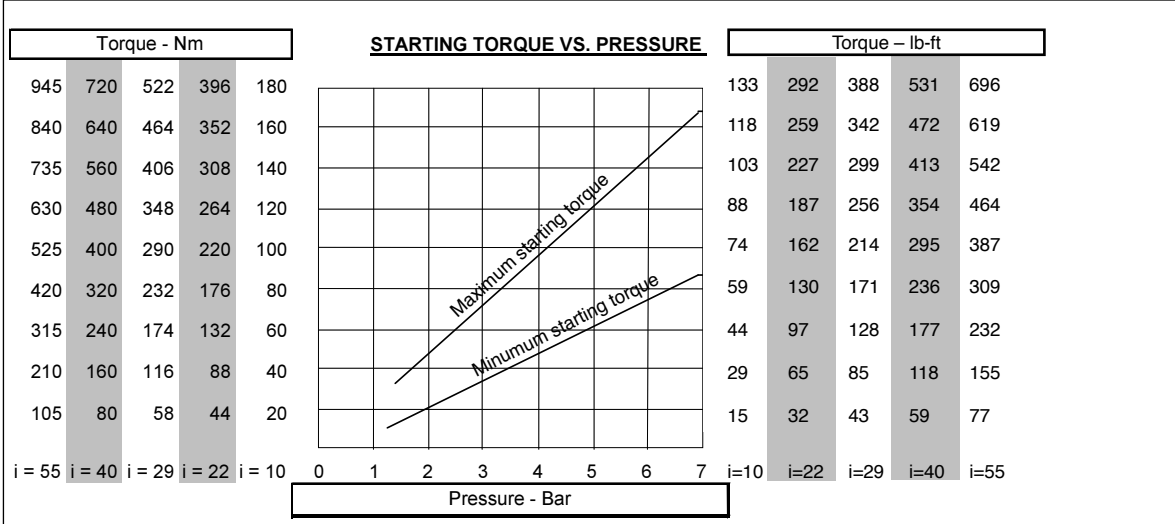
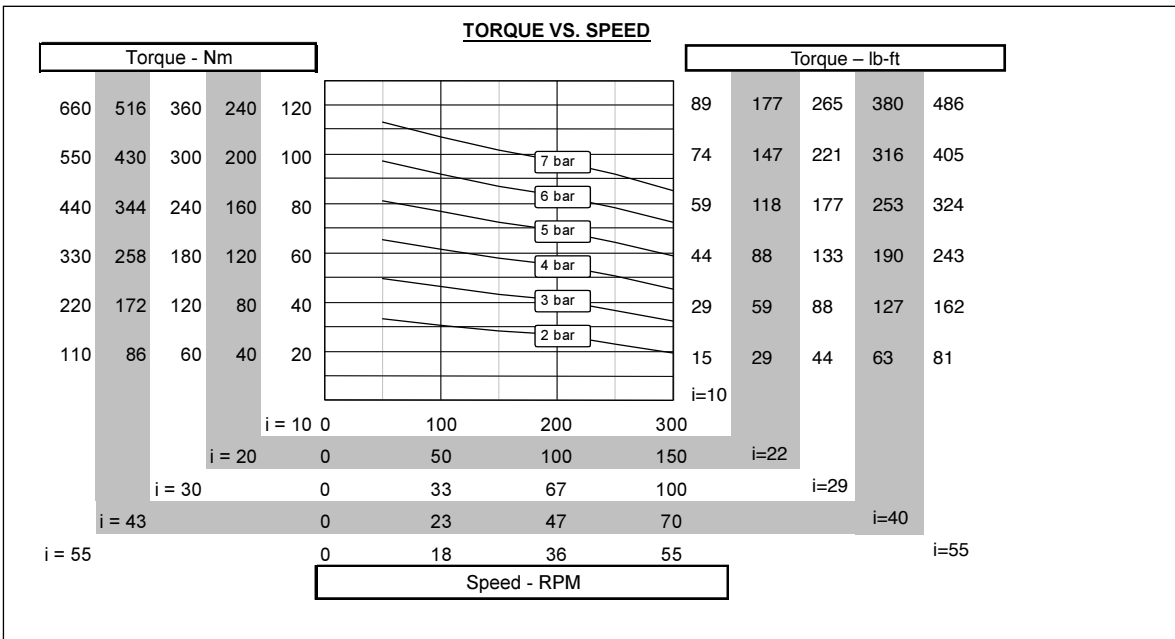

PERFORMANCES GLOBE VS8C AIR MOTOR WITH COAXIAL AND PLANETARY GEAR

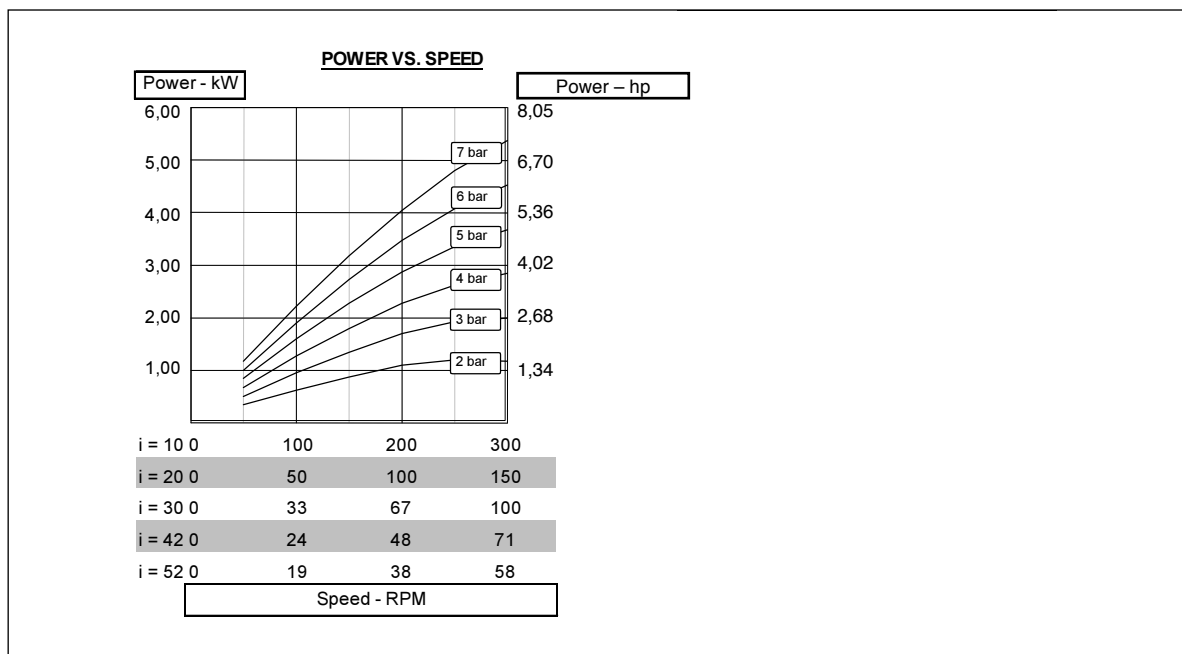
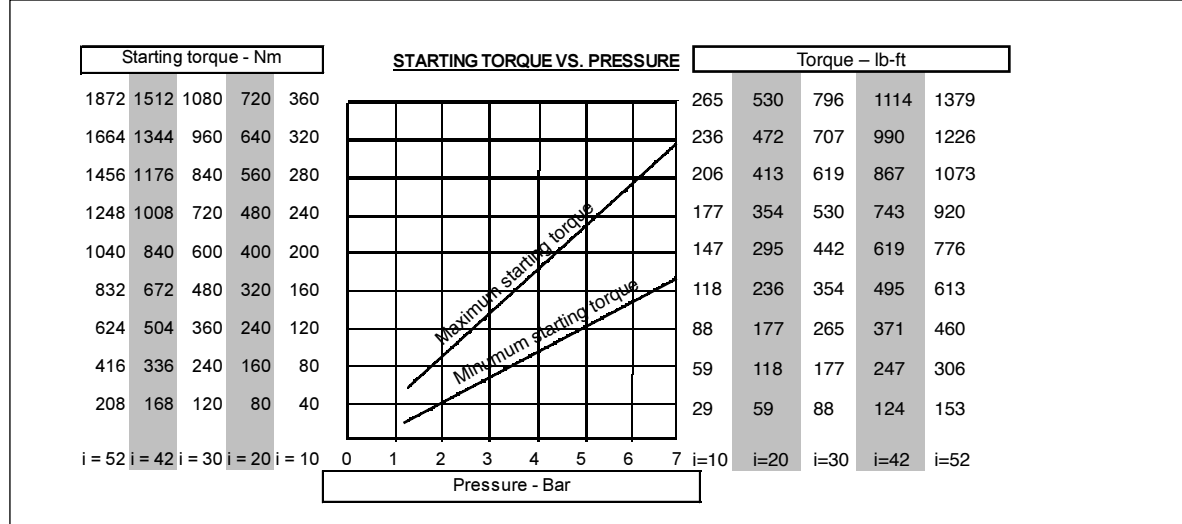
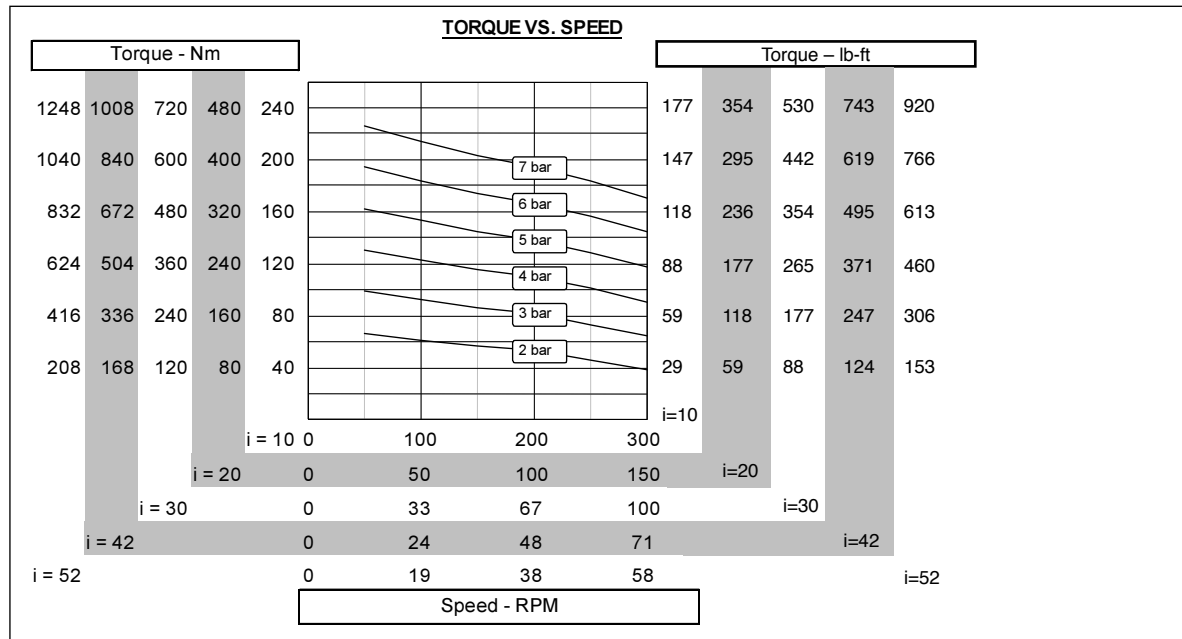

PERFORMANCES GLOBE VS10C AIR MOTOR WITH COAXIAL AND PLANETARY GEAR

RECOMMENDED GEARBOX LUBRICANTS

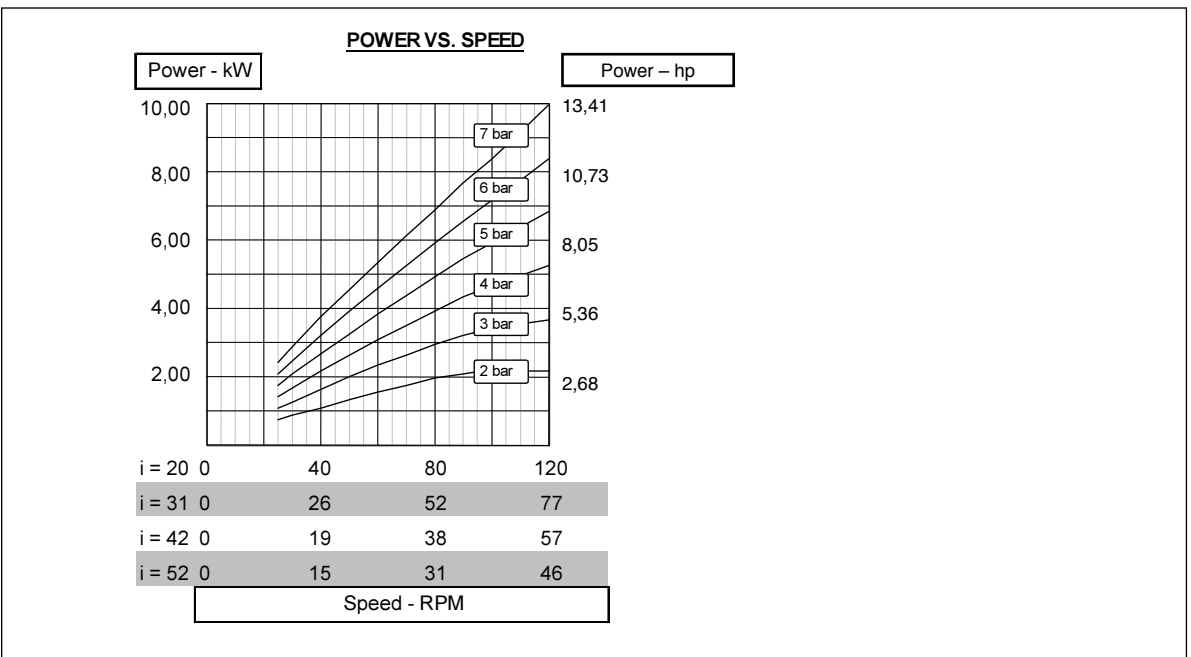
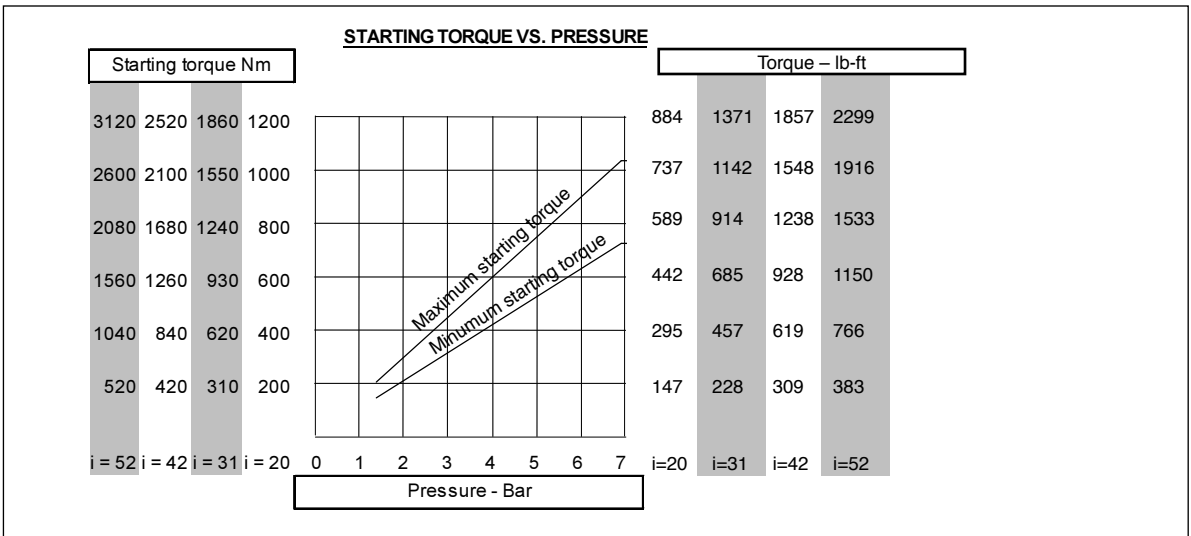
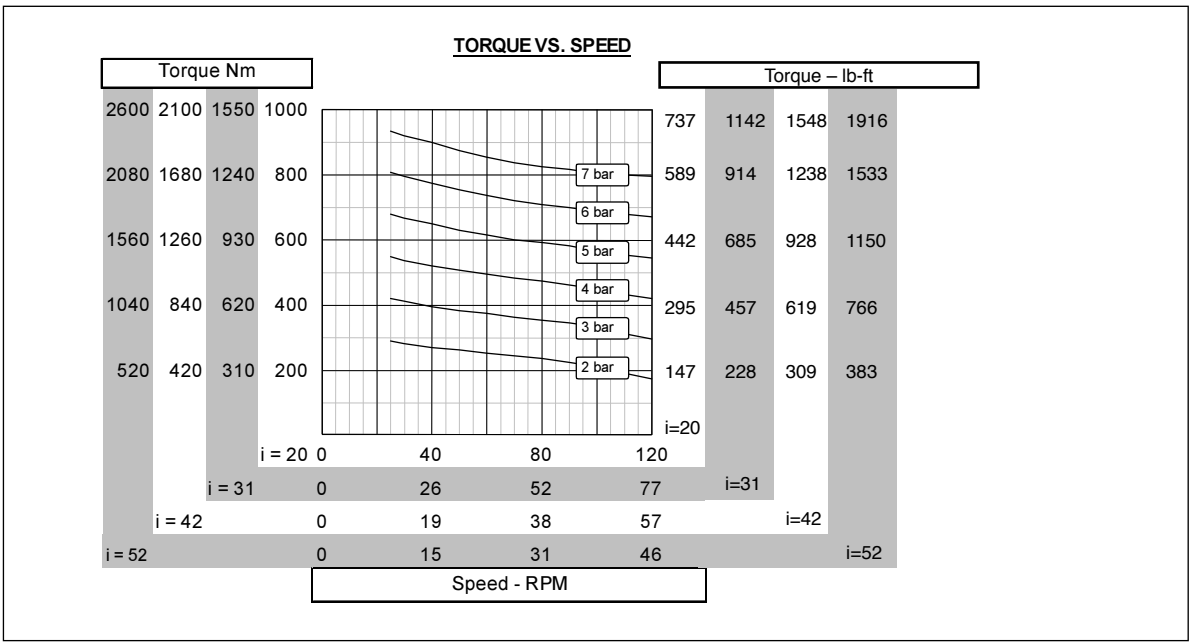

ISO VG	Synthetic oil			Mineral oil				
	460	220 320	150	680	460	320	220	
Ambient temperature (°C)	- 15° to 100°	- 25° to 80°	- 30° to 70°	5° to 50°	5° to 45°	0° to 40°	0° to 35°	
Manufacturer	AGIP	-	Telium VSF 320	Telium VSF 150	Blasia 680	Blasia 460	Blasia 320	Blasia 220
	BP	Energol SGXP 460	Energol SGXP 220	Energol SGXP 150	Energol GRXP 680	Energol GRXP 460	Energol GRXP 320	Energol GRXP 220
	ESSO	-	-	-	Spartan EP 680	Spartan EP 460	Spartan EP 320	Spartan EP 220
	SHELL	Tivela Oil SD	Tivela Oil WB	-	Omala Oil 680	Omala Oil 460	Omala Oil 320	Omala Oil 220
	KLÜBER	Syntheso D460 EP	Syntheso D220 EP	Syntheso D150 EP	Lamora 680	Lamora 460	Lamora 320	Lamora 220
	MOBIL	Glygoyle HE 460	Glygoyle 30	Glygoyle 22	Mobilgear 636	Mobilgear 636	Mobilgear 632	Mobilgear 630

GLOBE PFG-RED PLANETARY GEARED VANE MOTORS

The GLOBE PFG-red motors are of the vane type and are available with a wide range of planetary reducers ranging from $i = 3:1$ to $i = 1000:1$ (reductions above $i = 100:1$ on request)

GLOBE PFG-red motors are designed for light and medium industrial applications and are used in all kinds of driving, mixing and transporting applications.

- Available from 0,44 kW to 2,1 kW. Higher powers available on request.
- Easily variable speed control
- Variable torque control
- Perfect in many applications in hazardous environments
- Explosion proof according ATEX directive EU 94/9/EC (ATEX II cat. 2 G&D T5)
- No damage by overload or repeated starting
- Cool running
- Can be used in stall conditions
- Superior power to weight ratio
- Instantly reversible
- No shock start-up
- Maintenance-free
- Suitable for oil-free operation
- Radial and axial loads permitted
- Oil free possible



ORDERING CODES

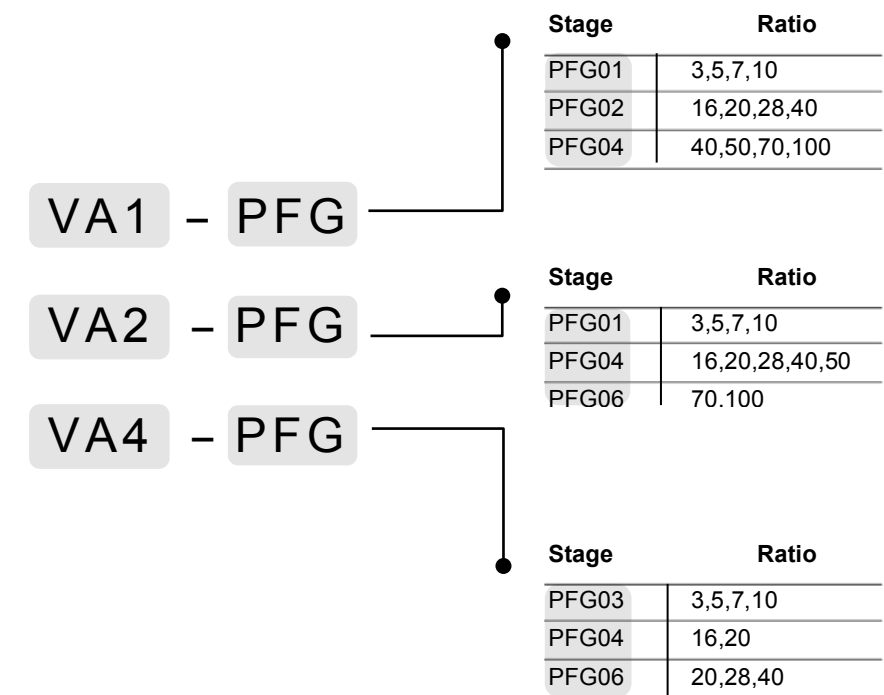

Use the ordering codes to create the GLOBE PFG Air Motor Unit you want.

For example: VA1PFG02 $i=16$ or VA4PFG07 $i=70$

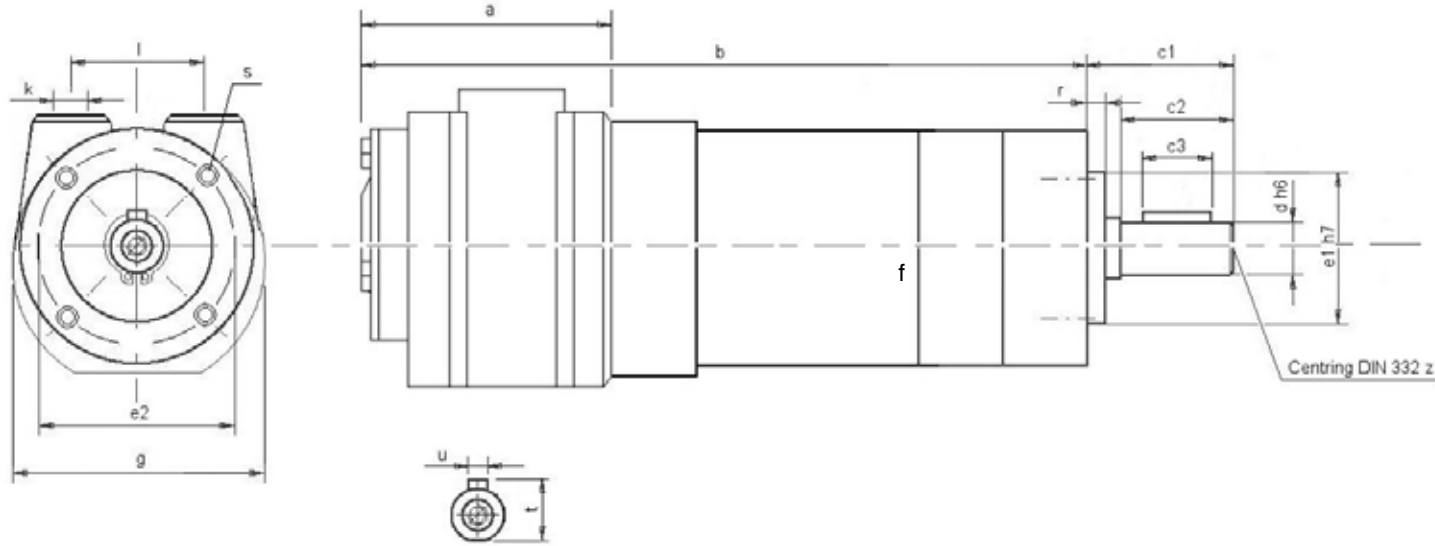

Motor	i	a	b	c1	c2	c3	d	e1	e2	f	g	k
VA1PFG01	3 5 7 10	69 (2.71")	175 (6.89")	39 (1.53")	30 (1.18")	25 (0.98")	14k6 (0.55")	40h7 (1.57")	52 (2.05")	65 (2.56")	71 (2.79")	1/4"NPT
VA1PFG02	16 20 28 40	69 (2.71")	198 (7.79")	39 (1.53")	30 (1.18")	25 (0.98")	14k6 (0.55")	40h7 (1.57")	52 (2.05")	65 (2.56")	71 (2.79")	1/4"NPT
VA1PFG04	40 50 70 100	69 (2.71")	226 (8.89")	49 (1.93")	40 (1.57")	32 (1.26")	20k6 (0.79")	55h7 (2.16")	70 (2.76")	85 (3.35")	71 (2.79")	1/4"NPT

Motor	l	r	s	t	u
VA1PFG01	36 (1.42")	8 (0.31")	M5x10 (0.39")	16 (0.63")	5 (0.19")
VA1PFG02	36 (1.42")	8 (0.31")	M5x10 (0.39")	16 (0.63")	5 (0.19")
VA1PFG04	36 (1.42")	8 (0.31")	M6x12 (0.47")	22,5 (0.88")	6 (0.23")

TORQUE - PRESSURE

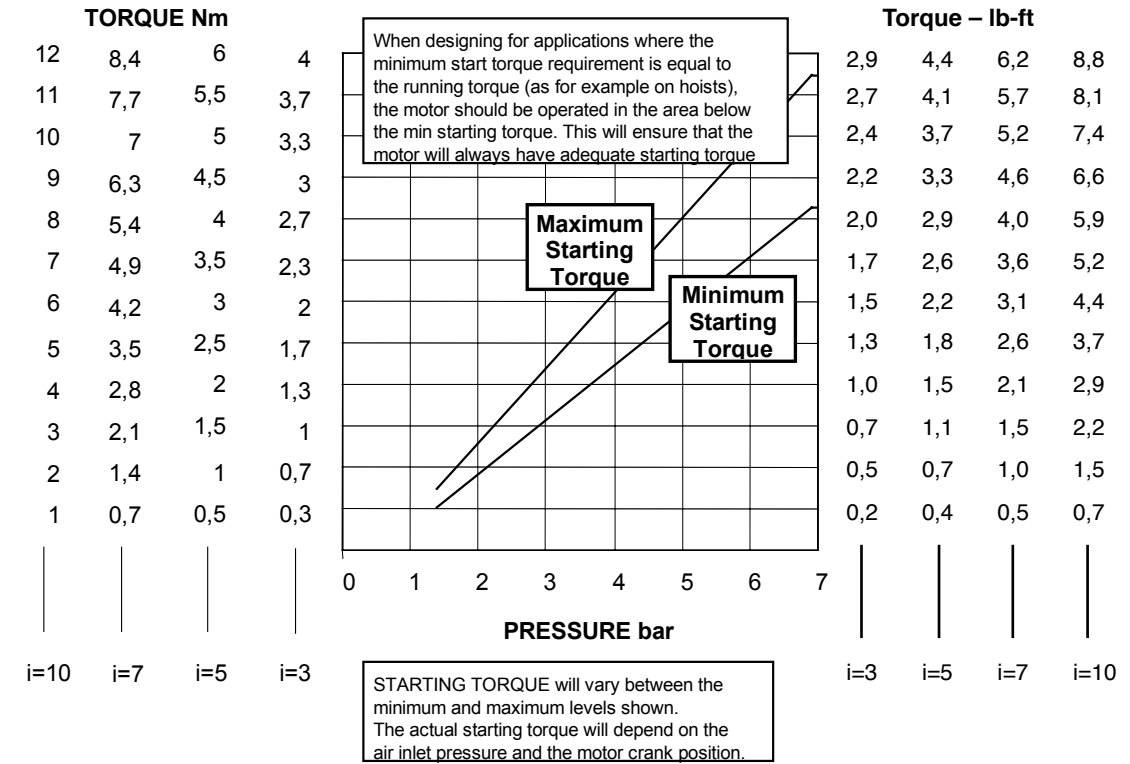

TORQUE - SPEED

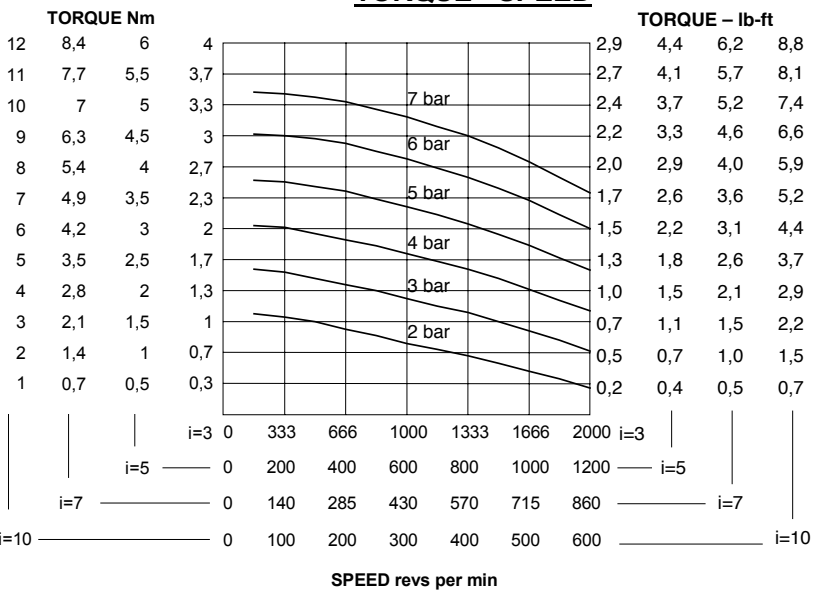

POWER - SPEED

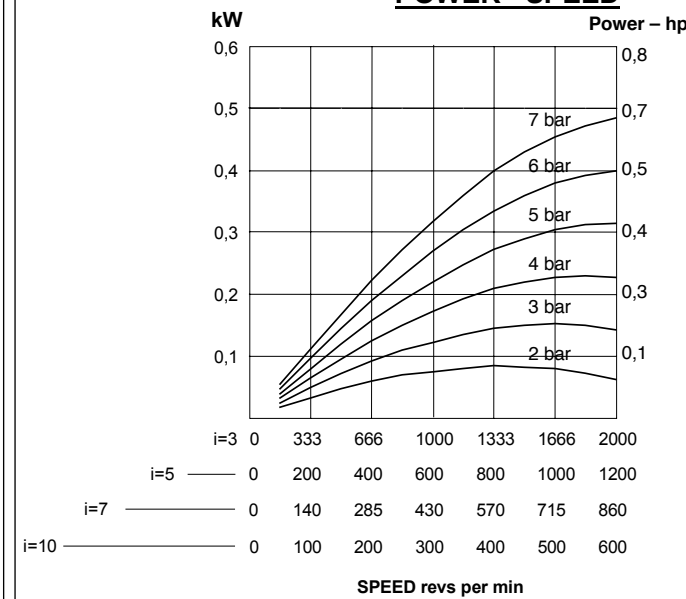

Motor is reversible.

ATTITUDE

The motor can be operated in all positions.

Maximum temperature -20°C to +80°C

(-4°F to -176°F).

Maximum radial load: 930 N

Maximum axial load: 1080 N

AIRLINE FILTRATION AND LUBRICATION

Use 64 micron filtration or better. Choose a lubricator suitable for the flow required. Prior to initial start-up, inject oil into the inlet port.

Lubricator drop rate 4-5 drops/minute continuous operation

Lubricator drop rate 9-12 drops/minute intermittent operation

TORQUE - SPEED

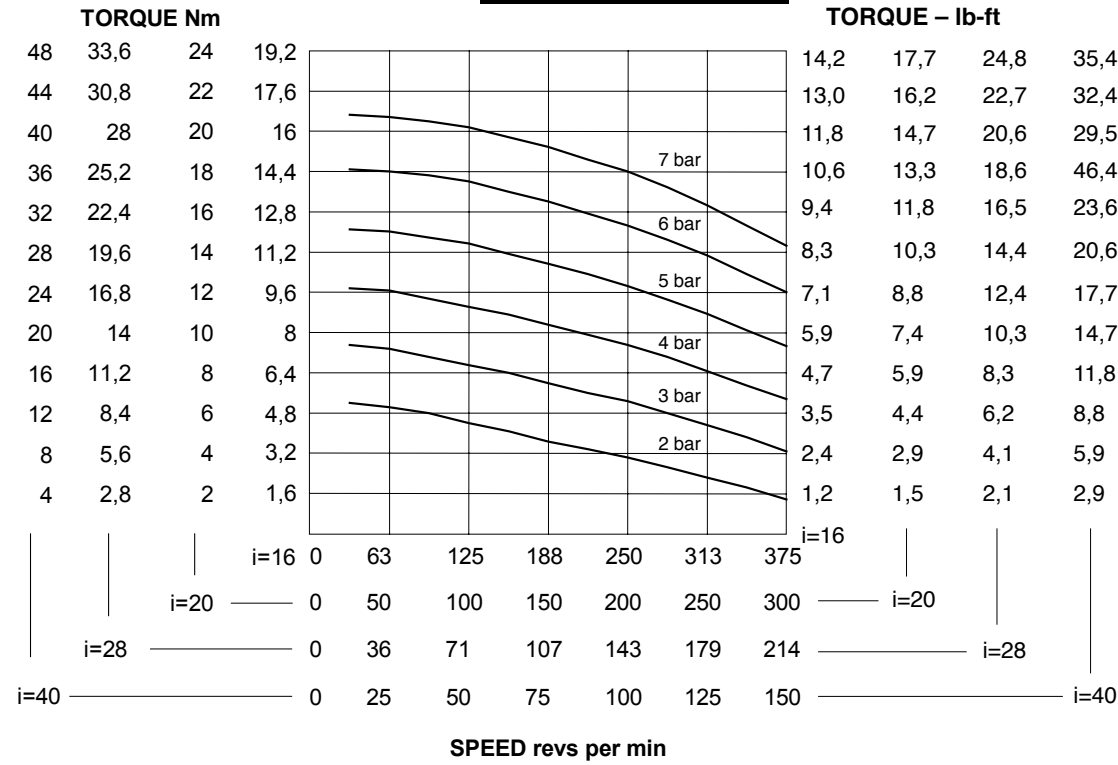

TORQUE - PRESSURE

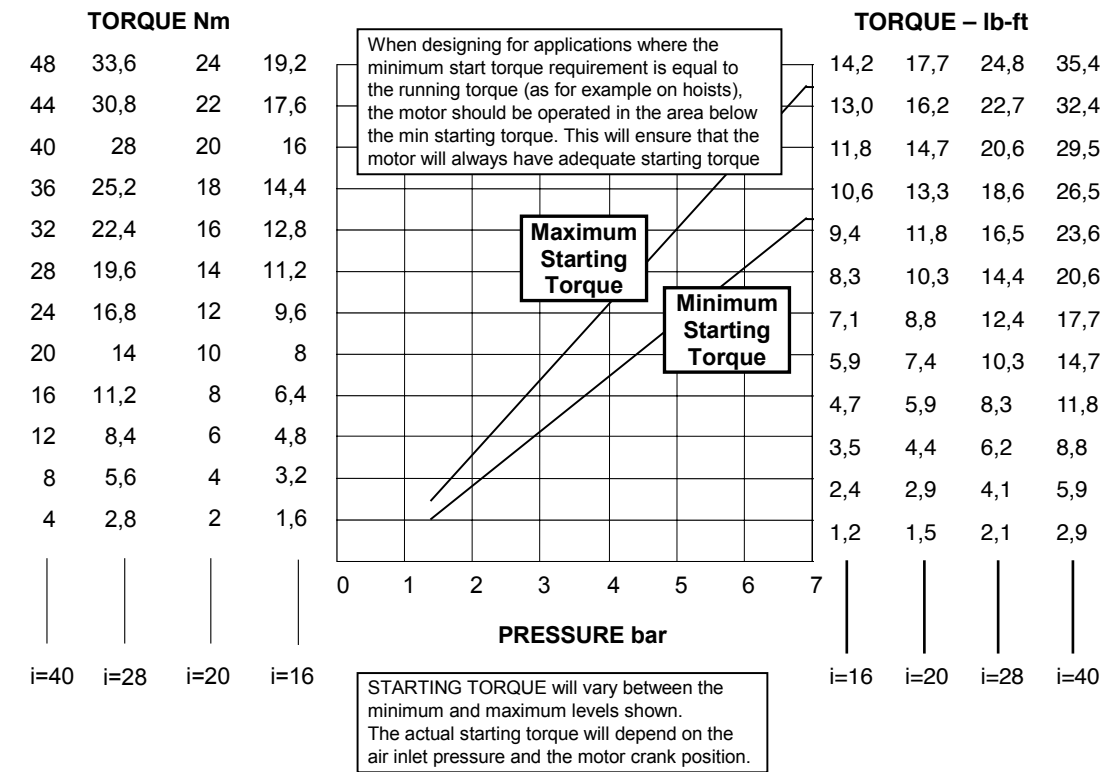

POWER - SPEED

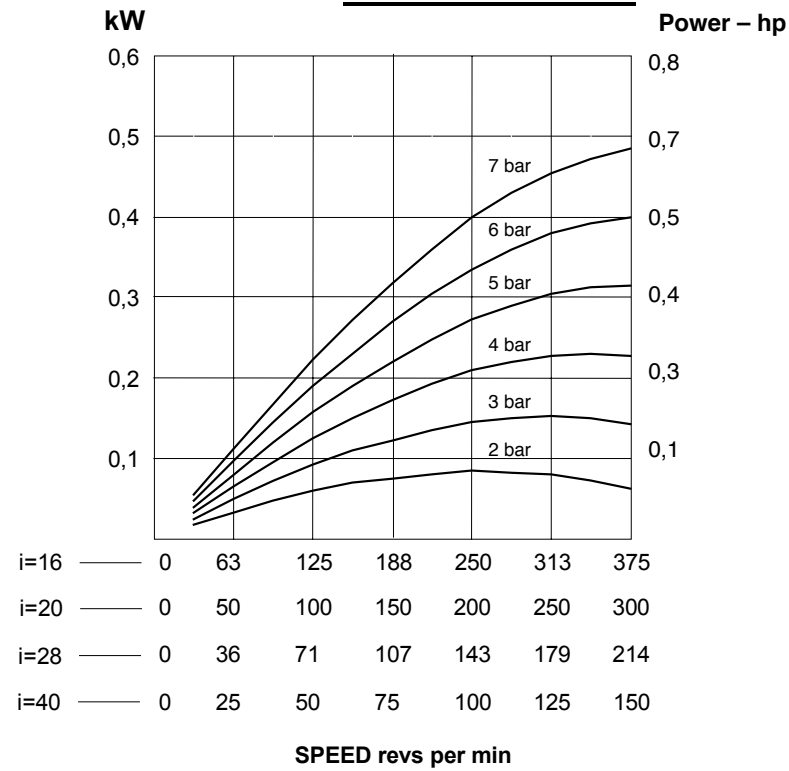

Motor is reversible.

ATTITUDE

The motor can be operated in all positions.

Maximum temperature -20°C to +80°C

(-4°F to -176°F).

Maximum radial load: 930 N

Maximum axial load: 1080 N

AIRLINE FILTRATION AND LUBRICATION

Use 64 micron filtration or better. Choose a lubricator suitable for the flow required. Prior to initial start-up, inject oil into the inlet port.

Lubricator drop rate 4-5 drops/minute continuous operation

Lubricator drop rate 9-12 drops/minute intermittent operation

TORQUE - SPEED

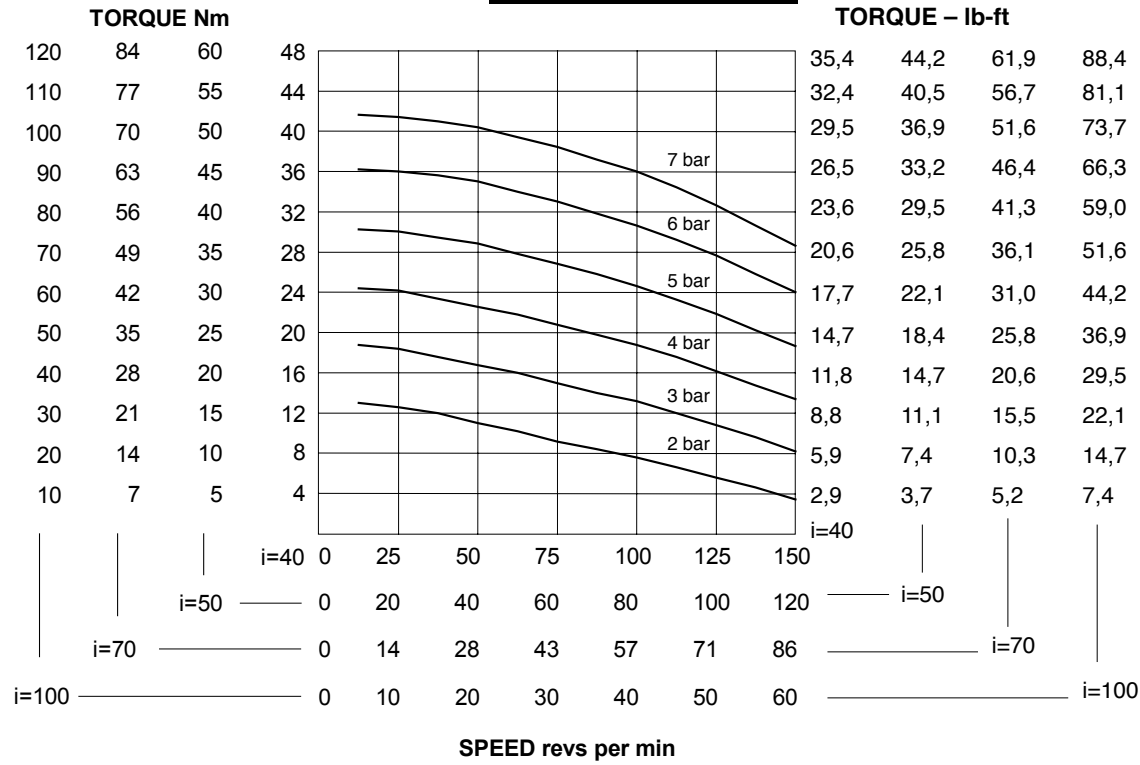

TORQUE - PRESSURE

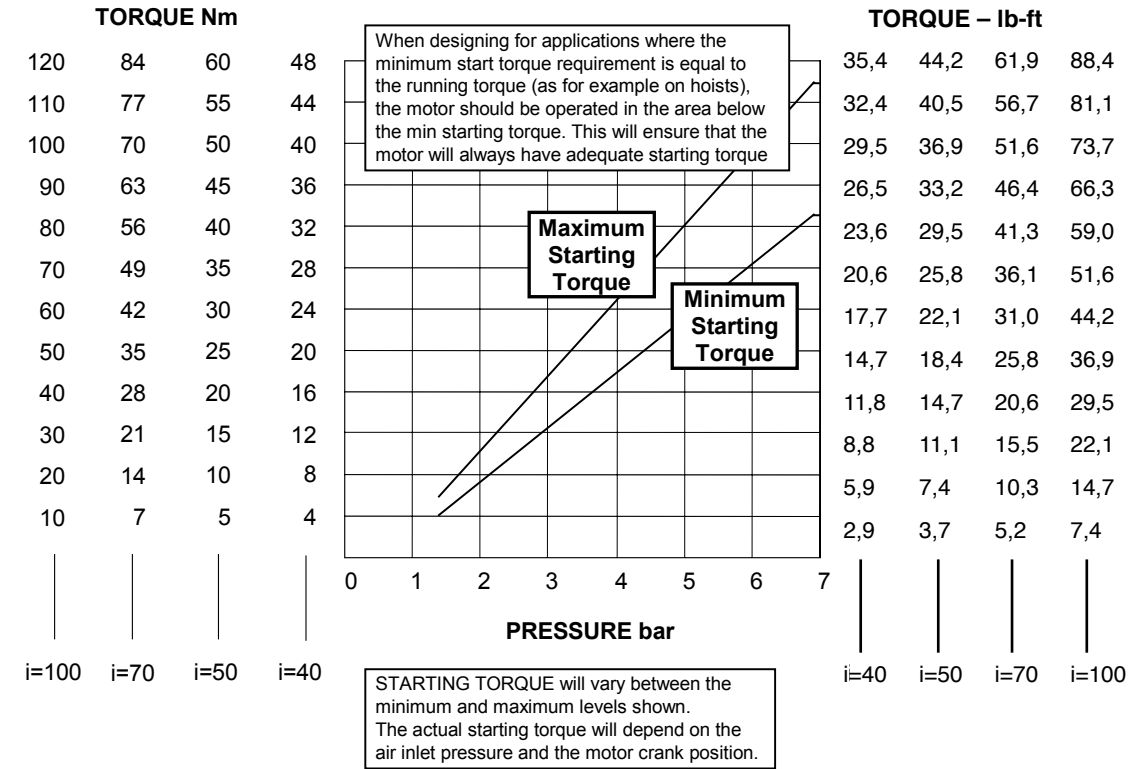

POWER - SPEED

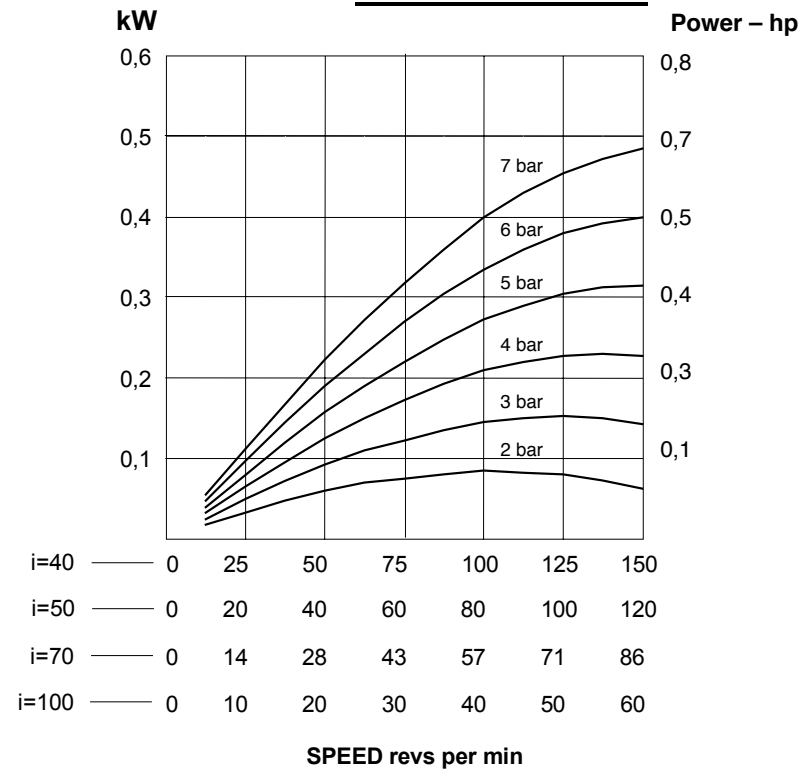

Motor is reversible.

ATTITUDE

The motor can be operated in all positions.

Maximum temperature -20°C to +80°C

(-4°F to -176°F).

Maximum radial load: 1770 N

Maximum axial load: 2180 N

AIRLINE FILTRATION AND LUBRICATION

Use 64 micron filtration or better. Choose a lubricator suitable for the flow required. Prior to initial start-up, inject oil into the inlet port.

Lubricator drop rate 4-5 drops/minute continuous operation

Lubricator drop rate 9-12 drops/minute intermittent operation

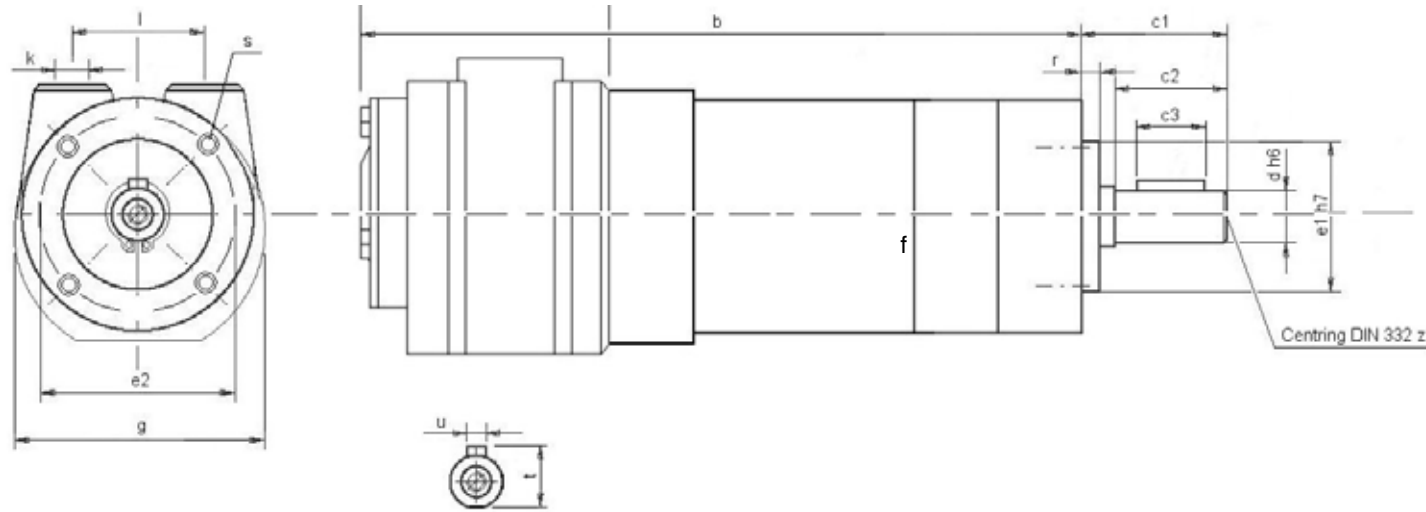

Motor	i	a	b	c1	c2	c3	d	e1	e2	f	g
VA2PFG01	3 5 7 10	72 (2.83")	174 (6.85")	39 (1.54")	30 (1.18")	25 (0.98")	14 k6 (0.55")	40 h7 (1.57")	52 (2.05")	65 (2.56")	102 (4.02")
VA2PFG04	16 20 28 40 50	72 (2.83")	227 (8.94")	49 (1.93")	40 (1.57")	32 (1.26")	20k6 (0.79")	55 h7 (2.17")	70 (2.76")	85 (3.35")	102 (4.02")
VA2PFG06	70 100	72 (2.83")	254 (10.00")	61 (2.40")	50 (1.97")	40 (1.57")	25 k6 (0.98")	80 h7 (3.15")	100 (3.94")	120 (4.72")	102 (4.02")
VA2PFG08 On request	120 160 200	72 (2.83")	308 (12.12")	95 (3.74")	80 (3.14")	70 (2.75")	40 k6 (1.57")	110 h7 (4.33")	130 (5.11")	155 (6.10")	102 (4.01")

Motor	k	l	r	s	t	u
VA2PFG01	3/8"NPT	55 (2.17")	8 (0.31")	M5x10 (0.39")	16 (0.63")	5 (0.20")
VA2PFG04	3/8"NPT	55 (2.17")	8 (0.31")	M6x12 (0.47")	22.5 (0.89")	6 (0.24")
VA2PFG06	3/8"NPT	55 (2.17")	10 (0.39")	M10x20 (0.79")	28,0 (1.10")	8 (0.31")
VA2PFG08 On request	3/8"NPT	55 (2.17")	14 (0.55")	M10x20 (0.79")	43,0 (1.69")	12 (0.47")

TORQUE - SPEED

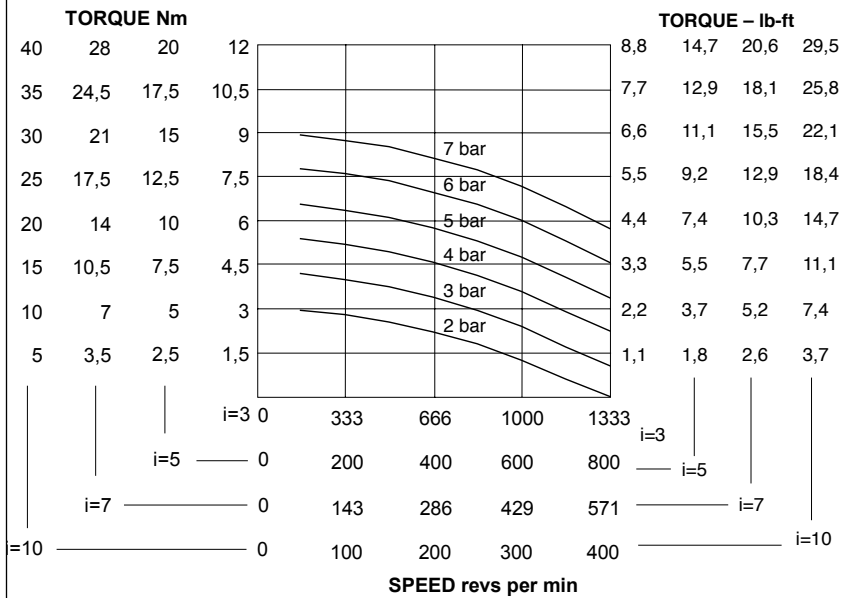

POWER - SPEED

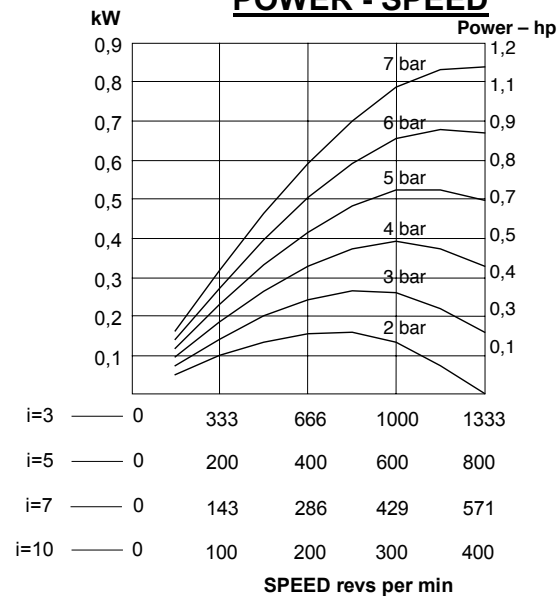

TORQUE - PRESSURE

TORQUE Nm	28	20	12
35	24,5	17,5	10,5
30	21	15	9
25	17,5	12,5	7,5
20	14	10	6
15	10,5	7,5	4,5
10	7	5	3
5	3,5	2,5	1,5

TORQUE - lb-ft	14,7	20,6	29,5
7,7	12,9	18,1	25,8
6,6	11,1	15,5	22,1
5,5	9,2	12,9	18,4
4,4	7,4	10,3	14,7
3,3	5,5	7,7	11,1
2,2	3,7	5,2	7,4
1,1	1,8	2,6	3,7

When designing for applications where the minimum start torque requirement is equal to the running torque (as for example on hoists), the motor should be operated in the area below the min starting torque. This will ensure that the motor will always have adequate starting torque

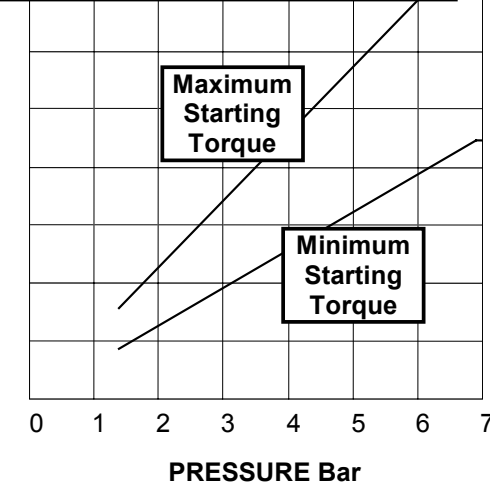

STARTING TORQUE will vary between the minimum and maximum levels shown. The actual starting torque will depend on the air inlet pressure and the motor crank position.

Muffler supplied with motor.
Motor is reversible.

ATTITUDE

The motor can be operated in all positions.
Maximum temperature -20°C to +80°C (-4°F to +176°F).
Maximum radial load: 930 N
Maximum axial load: 1080 N

AIRLINE FILTRATION AND LUBRICATION

Use 64 micron filtration or better. Choose a lubricator suitable for the flow required. Prior to initial start-up, inject oil into the inlet port.
Lubricator drop rate 4-5 drops/minute continuous operation
Lubricator drop rate 9-12 drops/minute intermittent operation

TORQUE - SPEED

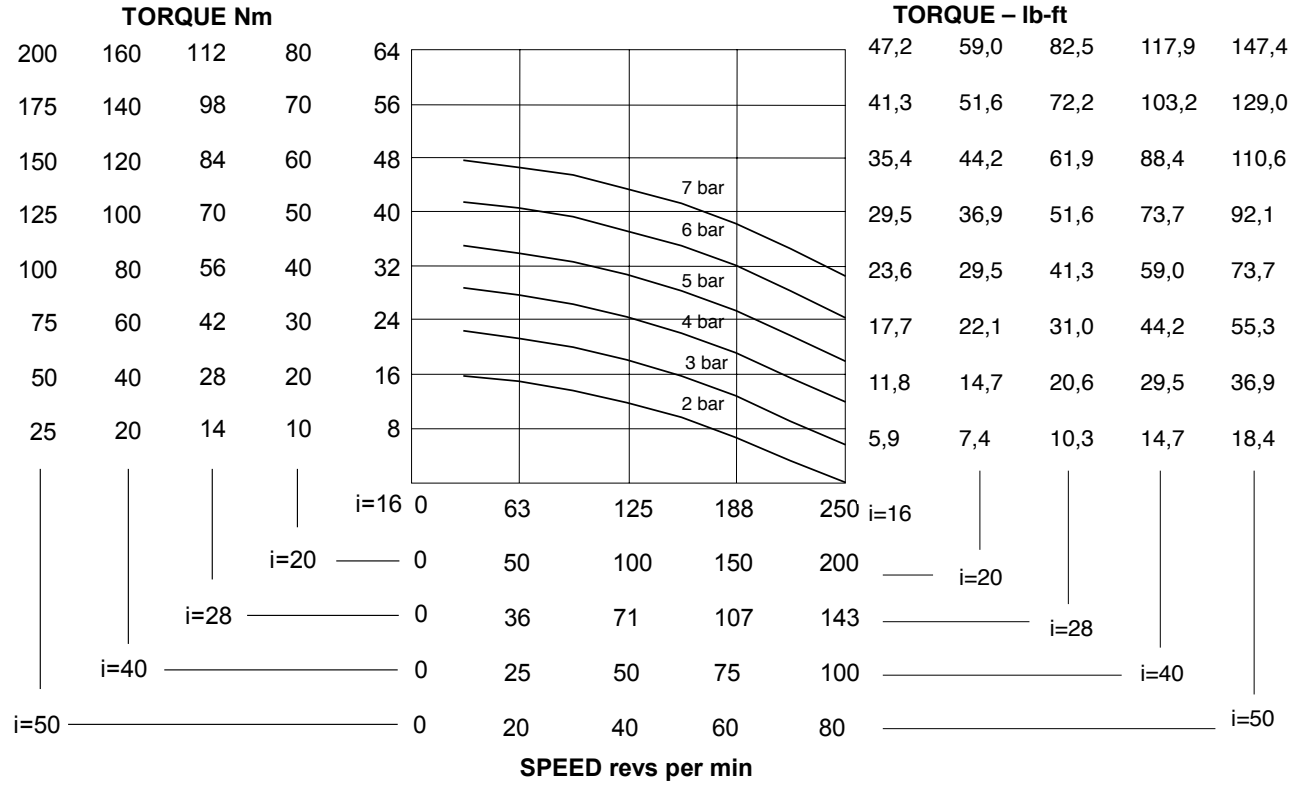

TORQUE - PRESSURE

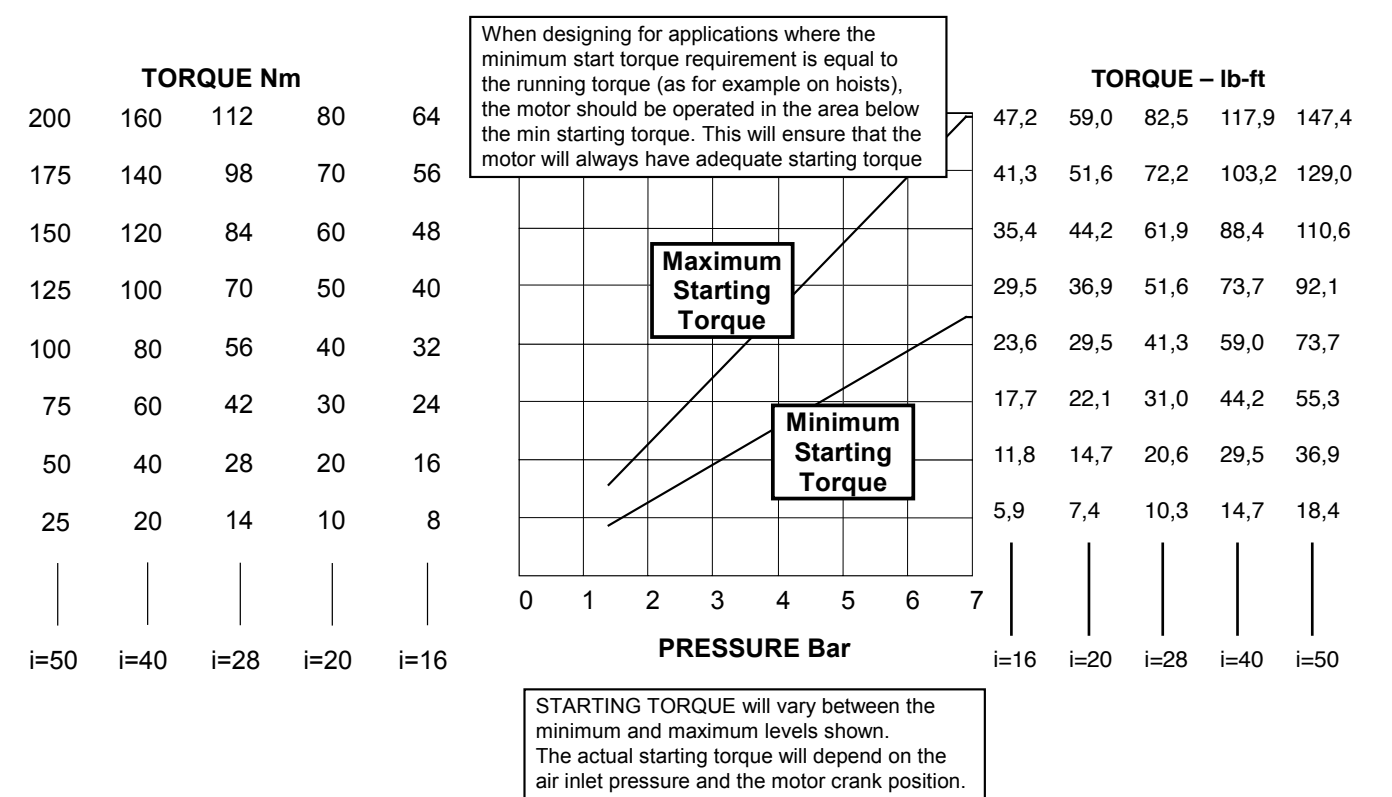

POWER - SPEED

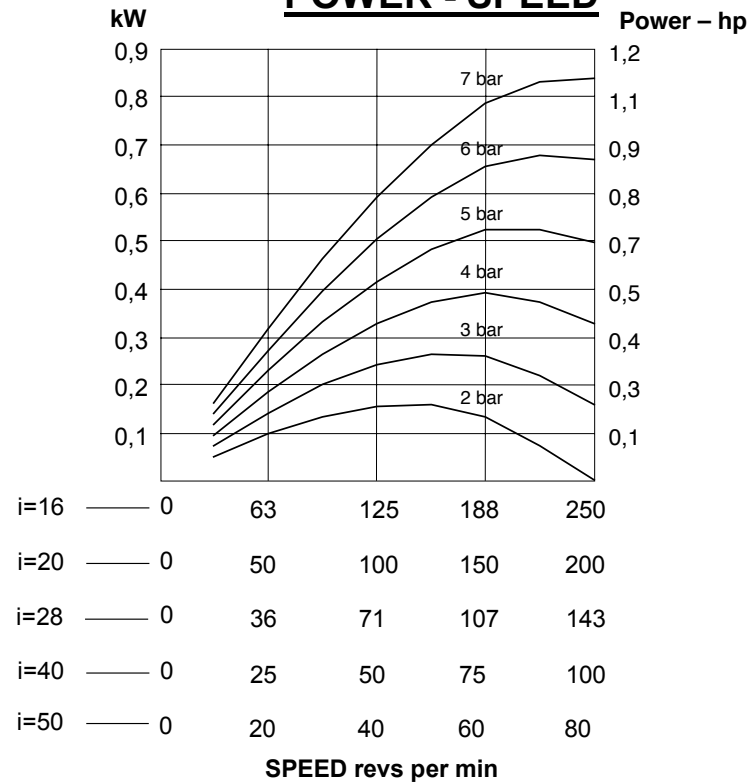

Muffler supplied with motor.

Motor is reversible.

ATTITUDE

The motor can be operated in all positions.

Maximum temperature -20°C to +80°C (-4°F to +176°F).

Maximum radial load: 1770 N

Maximum axial load: 2180 N

AIRLINE FILTRATION AND LUBRICATION

Use 64 micron filtration or better. Choose a lubricator suitable for the flow required. Prior to initial start-up, inject oil into the inlet port.

Lubricator drop rate 4-5 drops/minute continuous operation

Lubricator drop rate 9-12 drops/minute intermittent operation

TORQUE - SPEED

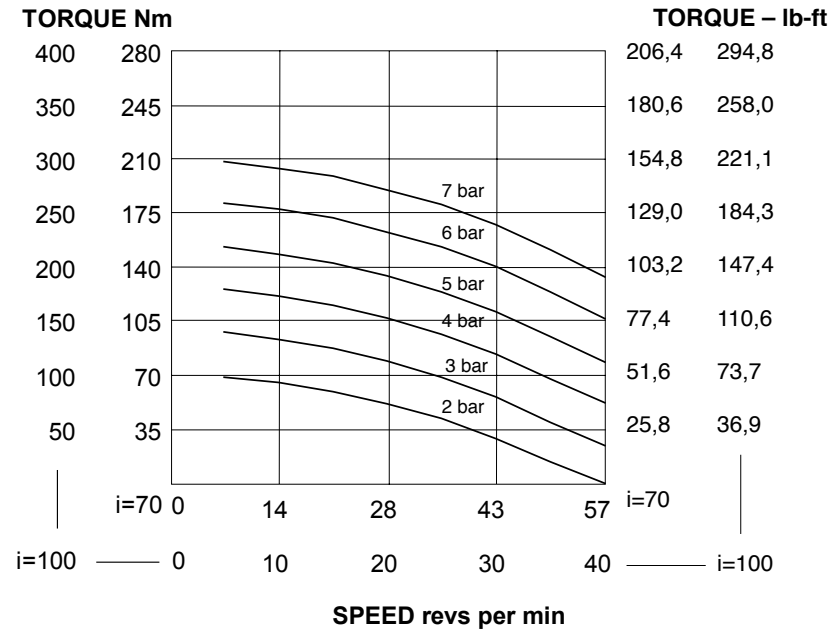

TORQUE - PRESSURE

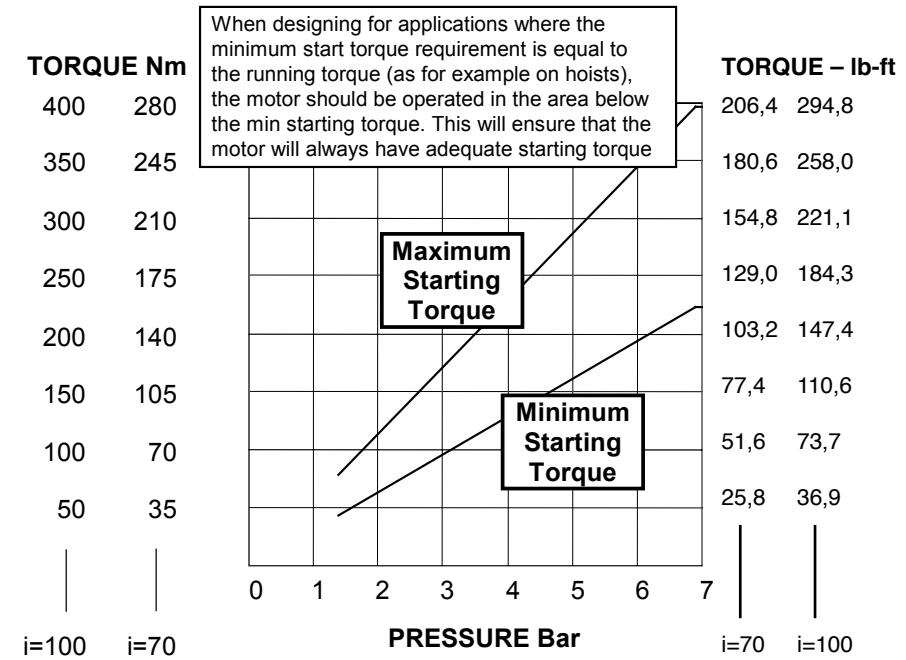

STARTING TORQUE will vary between the minimum and maximum levels shown. The actual starting torque will depend on the air inlet pressure and the motor crank position.

POWER - SPEED

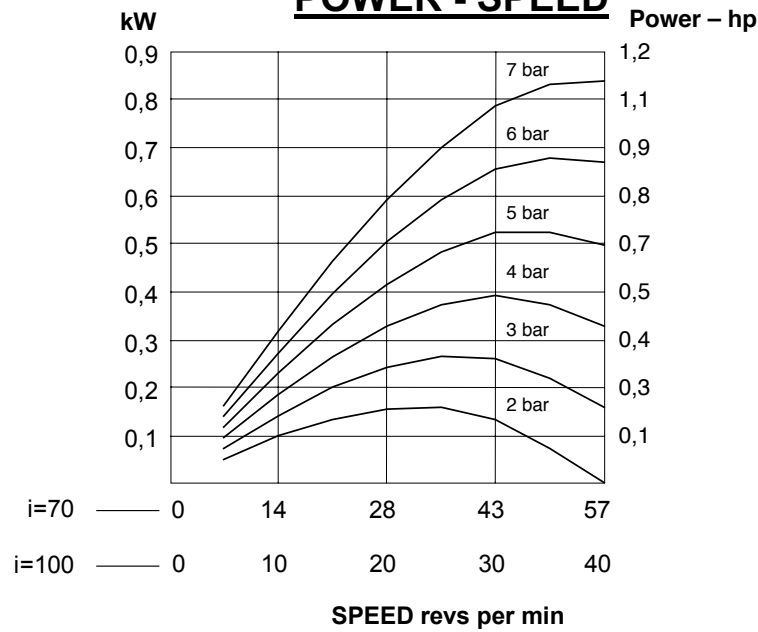

Muffler supplied with motor.

Motor is reversible.

ATTITUDE

The motor can be operated in all positions.

Maximum temperature -20°C to +80°C (-4°F to +176°F).

Maximum radial load: 3000 N

Maximum axial load: 3730 N

AIRLINE FILTRATION AND LUBRICATION

Use 64 micron filtration or better. Choose a lubricator suitable for the flow required. Prior to initial start-up, inject oil into the inlet port.

Lubricator drop rate 4-5 drops/minute continuous operation

Lubricator drop rate 9-12 drops/minute intermittent operation

TORQUE - SPEED

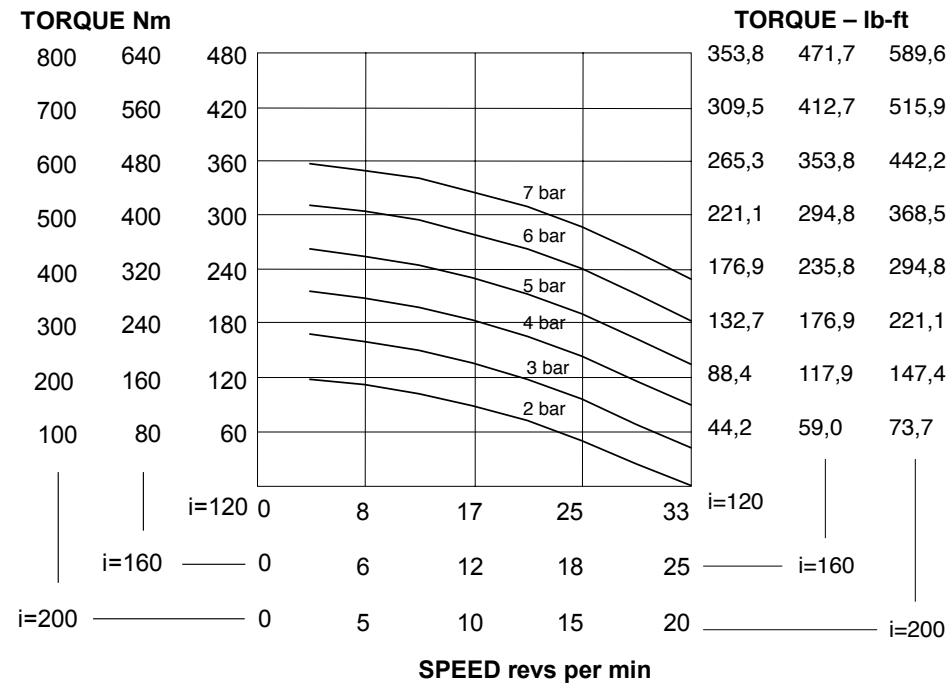

TORQUE - PRESSURE

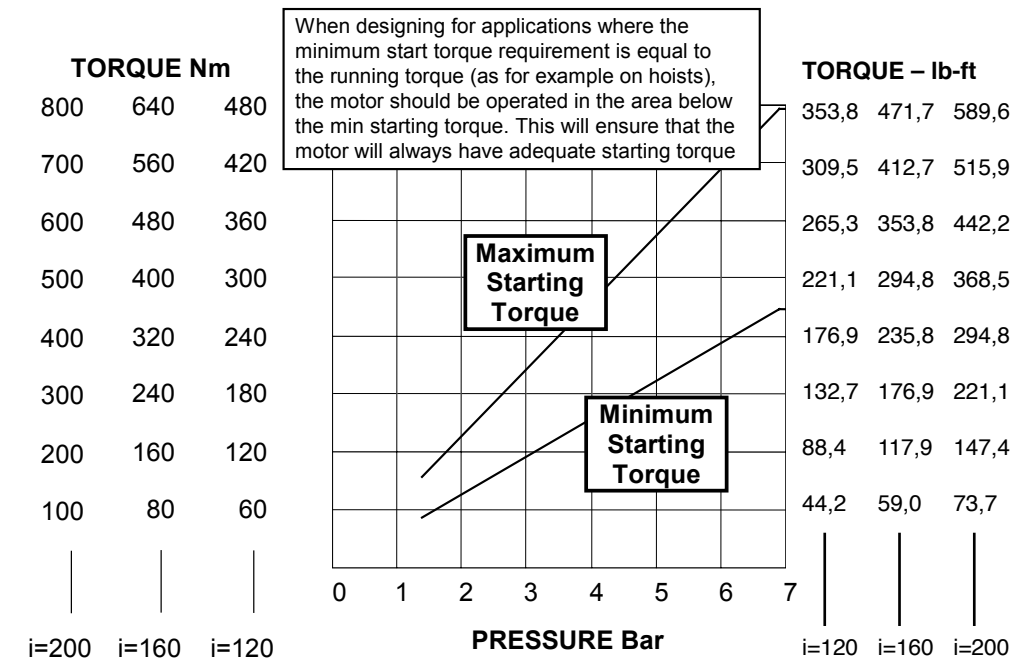

STARTING TORQUE will vary between the minimum and maximum levels shown. The actual starting torque will depend on the air inlet pressure and the motor crank position.

POWER - SPEED

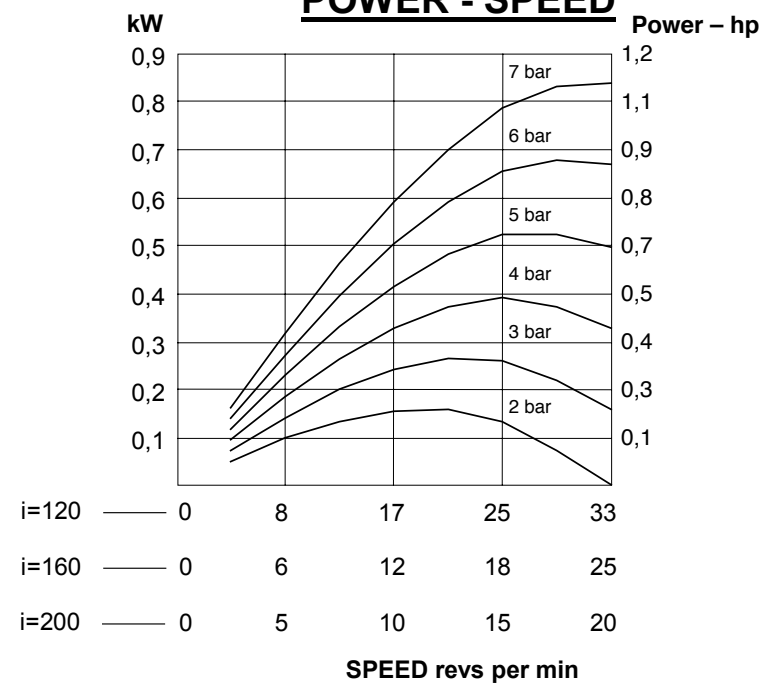

Muffler supplied with motor.

Motor is reversible.

ATTITUDE

The motor can be operated in all positions.

Maximum temperature -20°C to +80°C (-4°F to +176°F).

Maximum radial load: 8770 N

Maximum axial load: 7730 N

AIRLINE FILTRATION AND LUBRICATION

Use 64 micron filtration or better. Choose a lubricator suitable for the flow required. Prior to initial start-up, inject oil into the inlet port.

Lubricator drop rate 4-5 drops/minute continuous operation

Lubricator drop rate 9-12 drops/minute intermittent operation

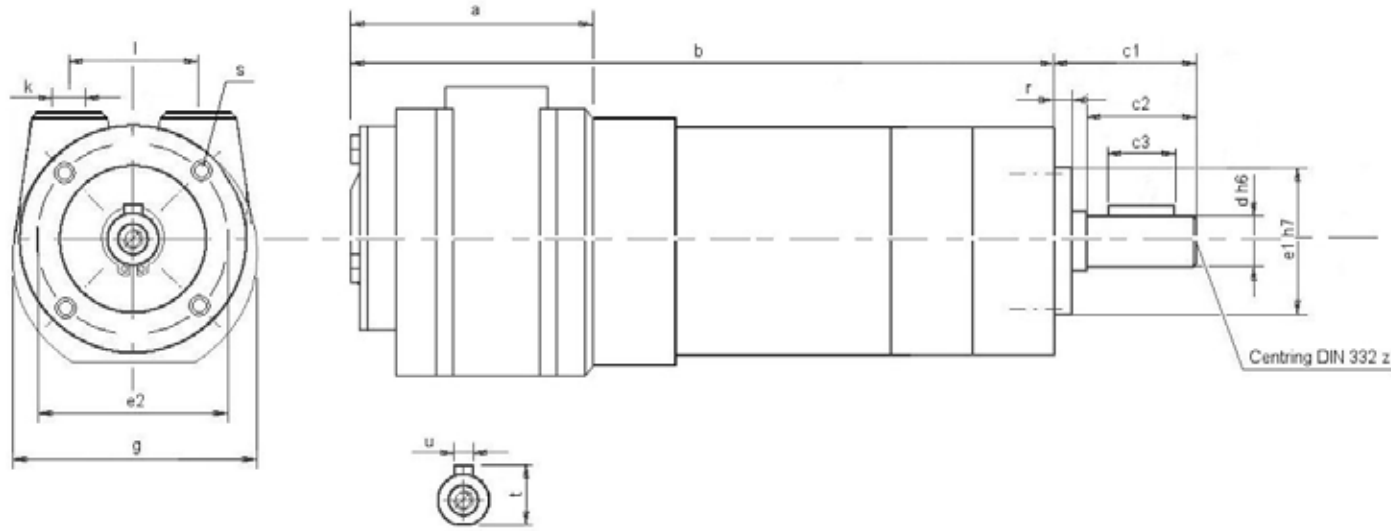

Motor	i	a	b	c1	c2	c3	d	e1	e2	f	g
VA4PFG03	3 5 7 10	89 (3.50")	213 (8.39")	49 (1.93")	40 (1.57")	32 (1.26")	20h6 (0.79")	55h7 (2.17")	70 (2.76")	85 (3.35")	102 (4.02")
VA4PFG04	16 20	89 (3.50")	244 (9.61")	49 (1.93")	40 (1.57")	32 (1.26")	20h6 (0.79")	55h7 (2.17")	70 (2.76")	85 (3.35")	102 (4.02")
VA4PFG06	20 28 40	89 (3.50")	271 (10.67")	61 (2.40")	50 (1.97")	40 (1.57")	25h6 (0.98")	80h7 (3.15")	100 (3.94")	120 (4.72")	102 (4.02")
VA4PFG07 On request	50 70	89 (3.50")	309 (12.17")	95 (3.74")	80 (3.15")	70 (2.76")	40h6 (1.57")	110h7 (4.33")	130 (5.12")	150 (5.91")	102 (4.02")

Motor	k	l	r	s	t	u
VA4PFG03	½"NPT	55 (2.17")	8 (0.31")	M6x12 (0.47")	22,5 (0.89")	6 (0.24")
VA4PFG04	½"NPT	55 (2.17")	8 (0.31")	M6x12 (0.47")	22,5 (0.89")	6 (0.24")
VA4PFG06	½"NPT	55 (2.17")	10 (0.39")	M8x16 (0.63")	28,0 (1.10")	8 (0.31")
VA4PFG07 On request	½"NPT	55 (2.17")	14 (0.55")	M10x20 (0.79")	43,0 (1.69")	12 (0.47")

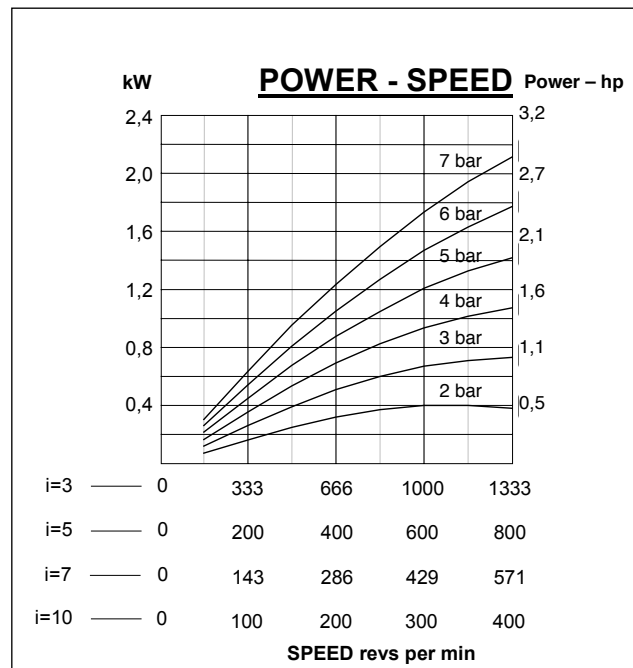
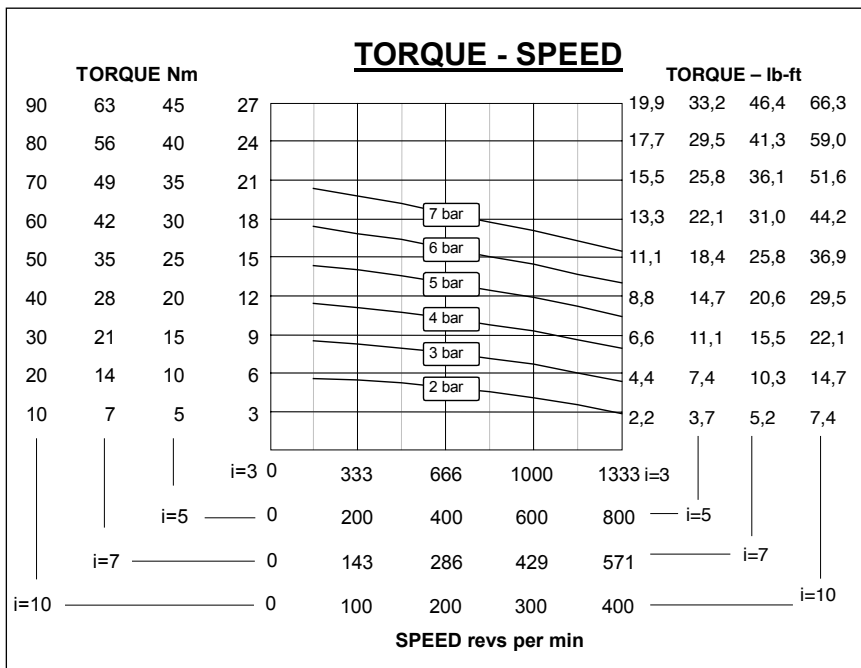

TORQUE - PRESSURE

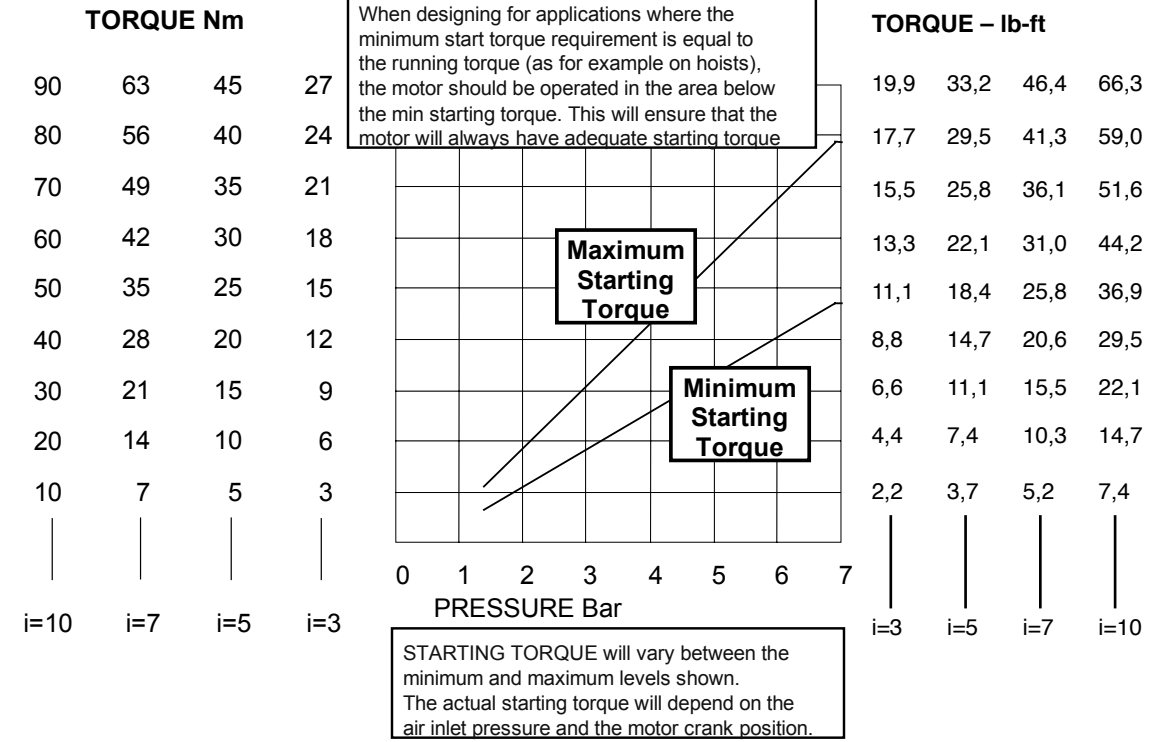

Muffler supplied with motor.

Motor is reversible.

ATTITUDE

The motor can be operated in all positions.

Maximum temperature -20°C to +80°C

(-4°F to -176°F).

Maximum radial load: 1770 N

Maximum axial load: 2180 N

AIRLINE FILTRATION AND LUBRICATION

Use 64 micron filtration or better. Choose a lubricator suitable for the flow required. Prior to initial start-up, inject oil into the inlet port.

Lubricator drop rate 4-5 drops/minute continuous operation

Lubricator drop rate 9-12 drops/minute intermittent operation

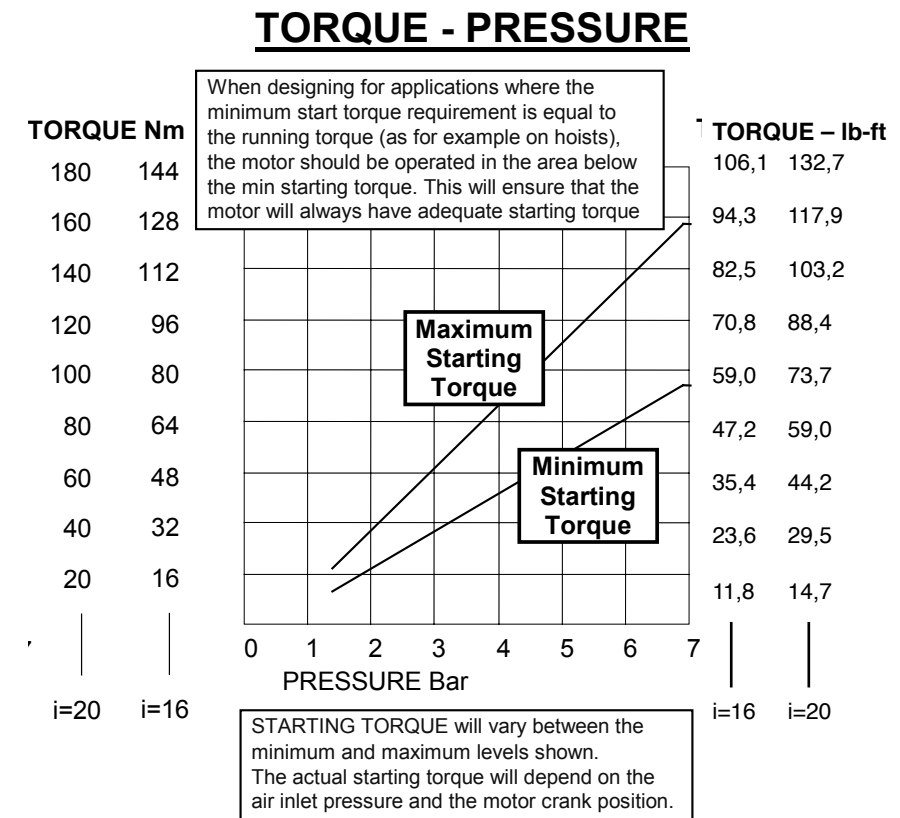
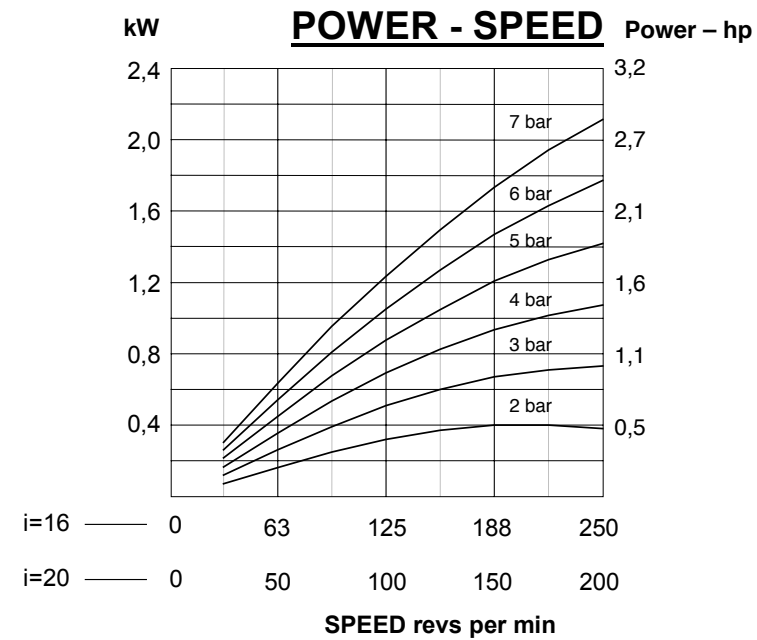
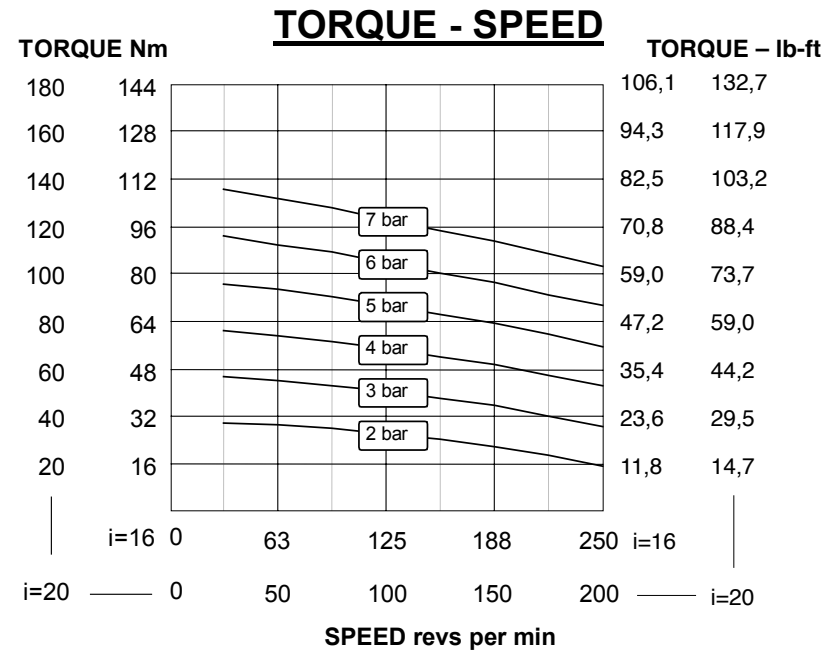

Muffler supplied with motor.

Motor is reversible.

ATTITUDE

The motor can be operated in all positions.

Maximum temperature -20°C to +80°C (-4°F to +176°F).

Maximum radial load: 1770 N

Maximum axial load: 2180 N

AIRLINE FILTRATION AND LUBRICATION

Use 64 micron filtration or better. Choose a lubricator suitable for the flow required. Prior to initial start-up, inject oil into the inlet port.

Lubricator drop rate 4-5 drops/minute continuous operation

Lubricator drop rate 9-12 drops/minute intermittent operation

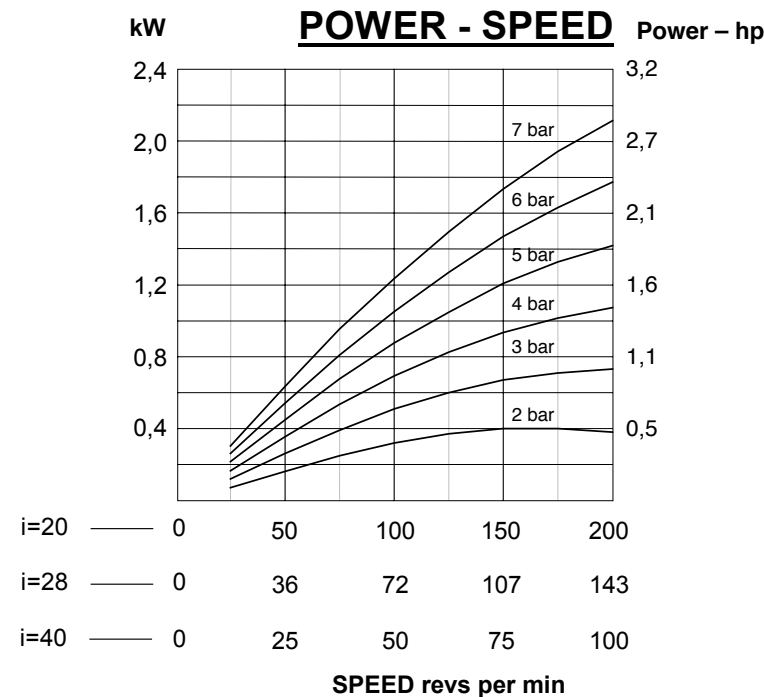
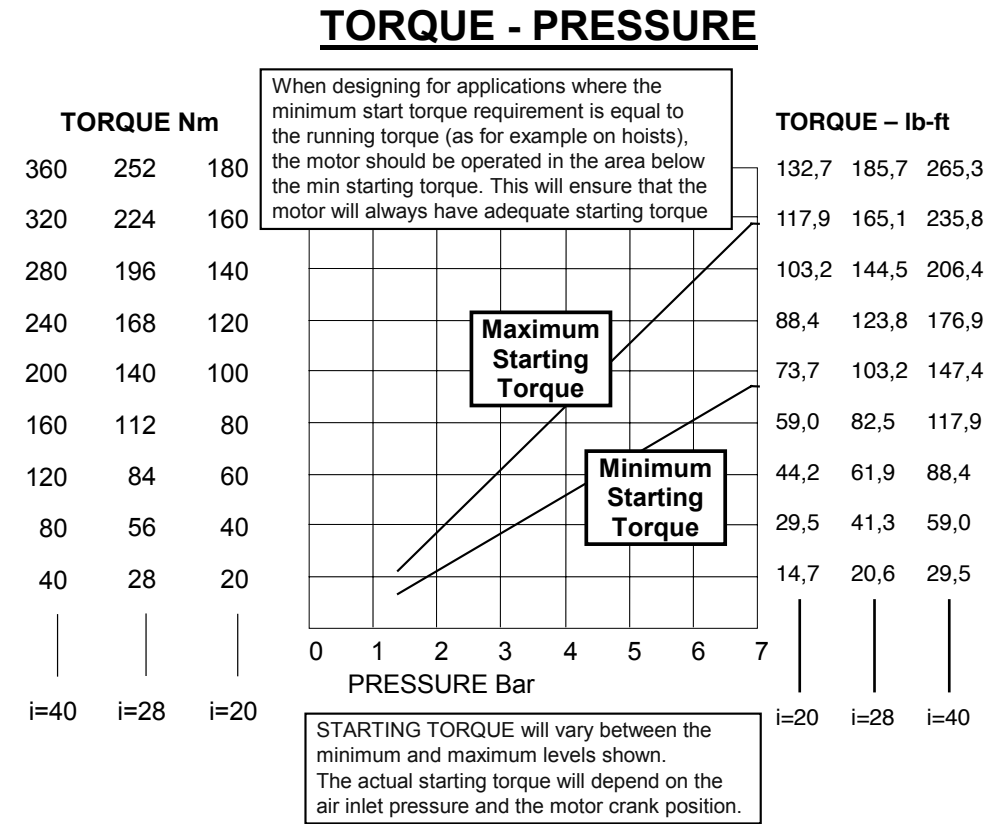
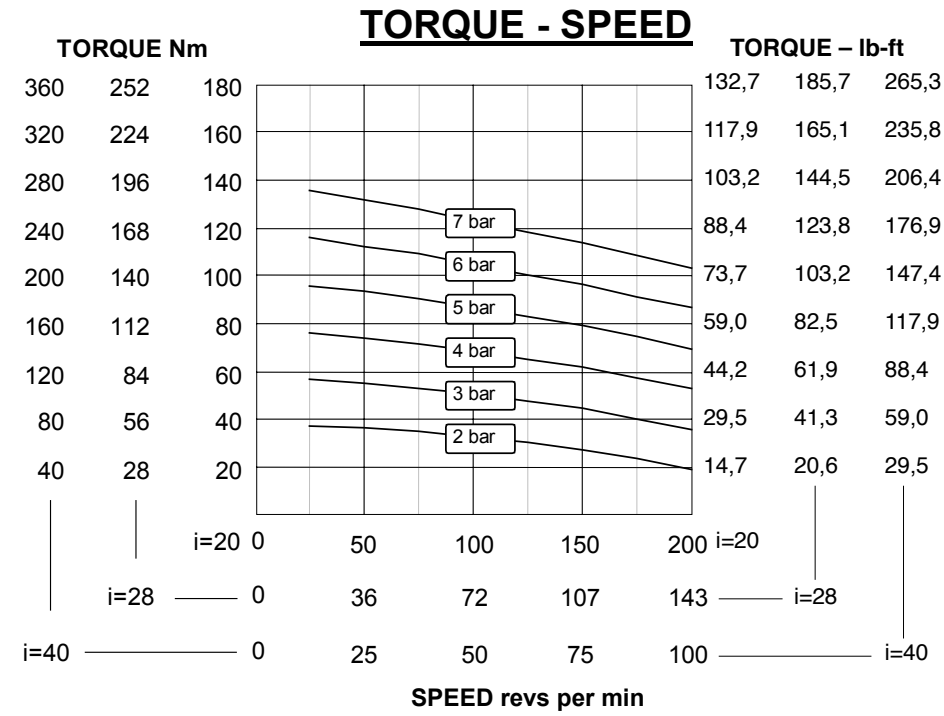

Muffler supplied with motor.

Motor is reversible.

ATTITUDE

The motor can be operated in all positions.

Maximum temperature -20°C to +80°C (-4°F to +176°F).

Maximum radial load: 3000 N

Maximum axial load: 3730 N

AIRLINE FILTRATION AND LUBRICATION

Use 64 micron filtration or better. Choose a lubricator suitable for the flow required. Prior to initial start-up, inject oil into the inlet port.

Lubricator drop rate 4-5 drops/minute continuous operation

Lubricator drop rate 9-12 drops/minute intermittent operation

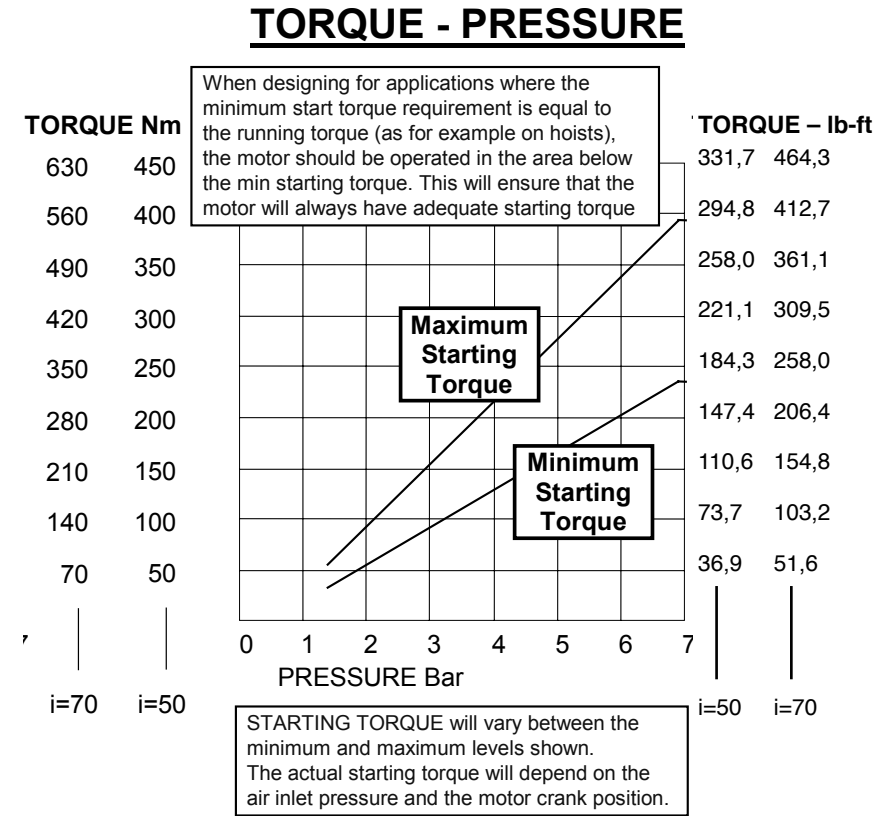
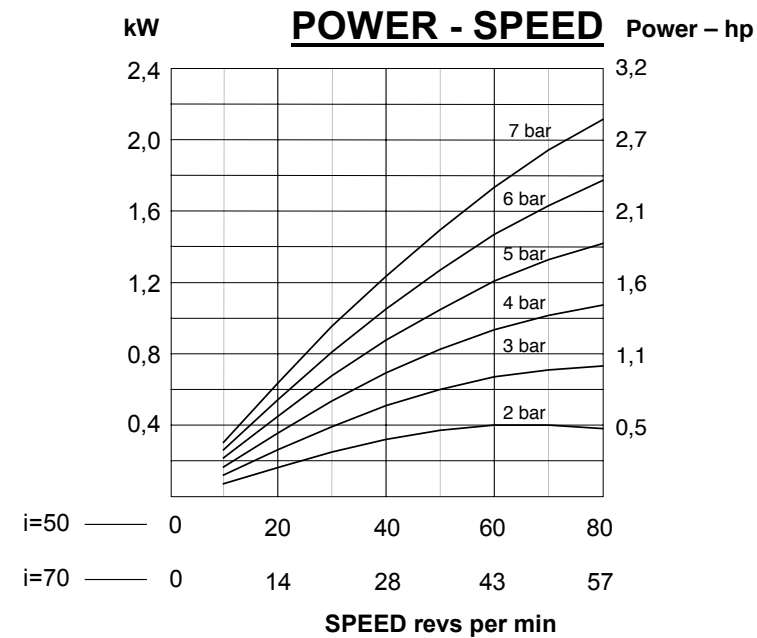
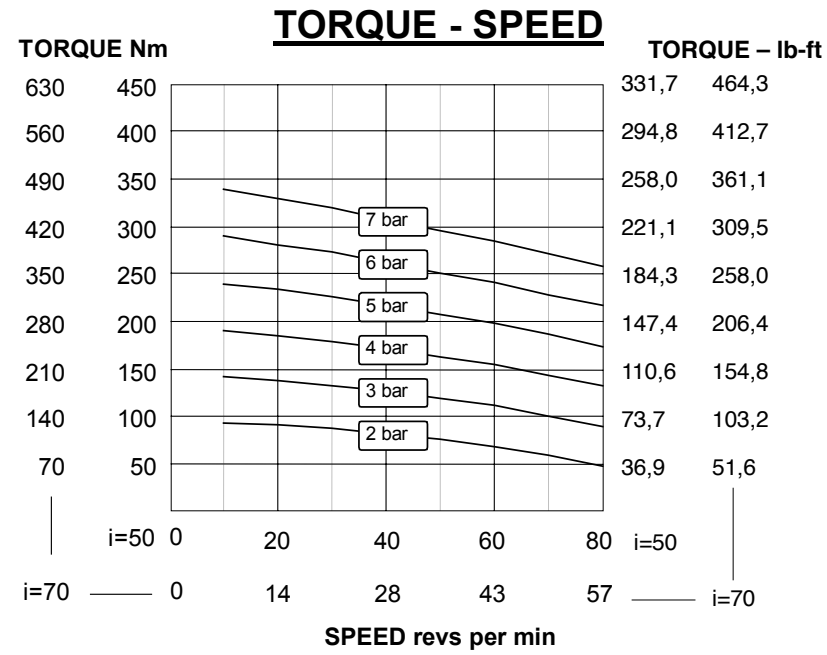

Muffler supplied with motor.

Motor is reversible.

ATTITUDE

The motor can be operated in all positions.

Maximum temperature -20°C to +80°C (-4°F to +176°F).

Maximum radial load: 6770 N

Maximum axial load: 7730 N

AIRLINE FILTRATION AND LUBRICATION

Use 64 micron filtration or better. Choose a lubricator suitable for the flow required. Prior to initial start-up, inject oil into the inlet port.

Lubricator drop rate 4-5 drops/minute continuous operation

Lubricator drop rate 9-12 drops/minute intermittent operation



VANE AIR MOTORS WITH BRAKE

The GLOBE vane air motors are also available in combination with a pneumatic brake.

The GLOBE BN brakes are fail-safe brakes (spring engaged, air released). They can be used as a static brake and under certain conditions in dynamic applications.

The pneumatic brake is mounted directly onto the vane air motor.

Vane air motors with brake are certified according to the European Explosive Directive ATEX II cat. 2 G&D T3 (in static applications only).

THE ADVANTAGES OF THE VANE AIR MOTORS WITH BRAKE INCLUDE:

- Braked vane air motors can be used in hold and emergency stop
- Field serviceable;
- Easy flange connection according to IEC and NEMA standards;
- Low maintenance because very few parts are exposed to wear;
- Compact design;
- Easy interchangeable because of independent brake module;
- Cast-iron or steel housing and excellent thermal capacity for use in harsh environments;
- Long life-time;
- Certified according to the European Explosive Directive ATEX II cat. 2 G&D T3.

GLOBE VANE MOTOR WITH BN BRAKE

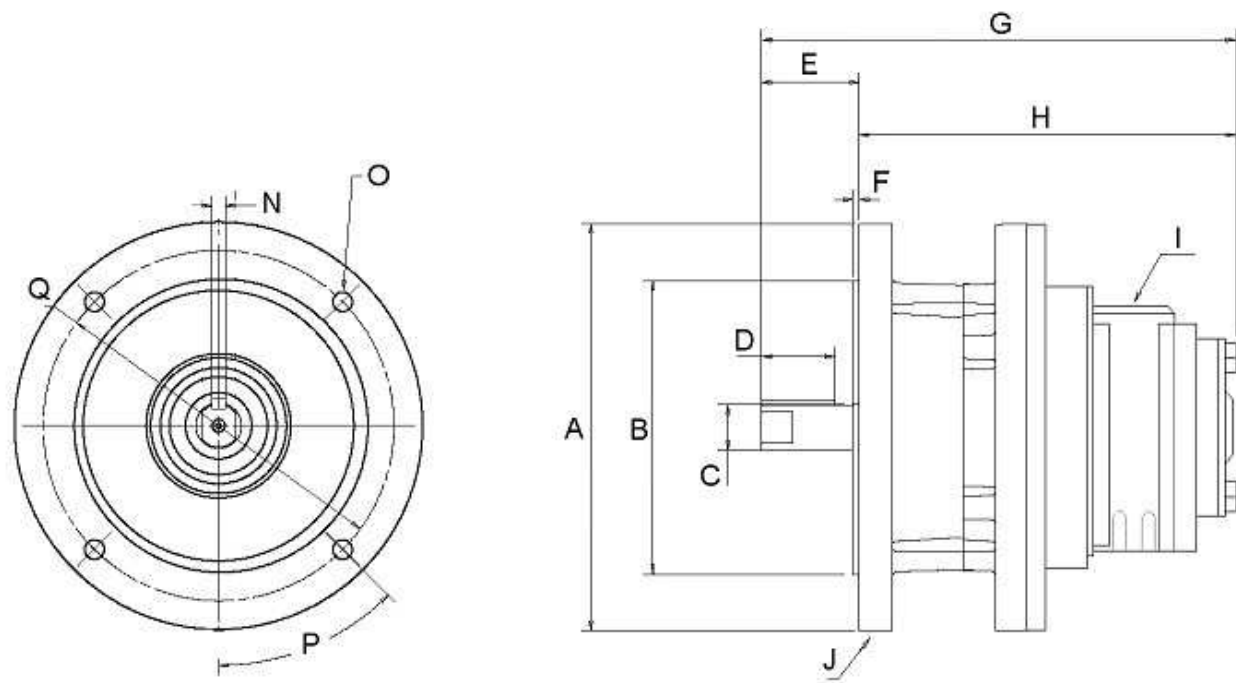

Braked air motor type	A Ø	B Ø	C Ø	D	E	F	G	H	I
VS4BN71	160 (6.30")	110H7 (4.33")	14H7 (0.55")	25 (0.98")	30 (1.18")	3,5 (0.14")	240 (9.45")	210 (8.27")	½ BSP
VS6BN90	200 (7.87")	130H7 (5.12")	24H7 (0.94")	35 (1.38")	50 (1.97")	5 (0.20")	347 (13.66")	297 (11.69")	¾ BSP
VS8BN90	200 (7.87")	130H7 (5.12")	24H7 (0.94")	35 (1.38")	50 (1.97")	5 (0.20")	350 (13.78")	300 (11.81")	1 BSP
VS10BN100	250 (9.84")	180H7 (7.09")	28H7 (1.10")	55 (2.17")	60 (2.36")	5 (0.20")	388 (15.28")	328 (12.91")	1 ¼ BSP

Braked air motor type	J	N	O Ø	P	Q Ø
VS4BN71	1/8BSP	5 (0.20")	10 (0.39")	45 (1.77")	130 (5.12")
VS6BN90	1/8BSP	8 (0.31")	10 (0.39")	45 (1.77")	165 (6.50")
VS8BN90	1/8BSP	8 (0.31")	10 (0.39")	45 (1.77")	165 (6.50")
VS10BN100	1/4BSP	8 (0.31")	12 (0.47")	45 (1.77")	215 (8.46")

		Holding Torque	Release pressure
VS4BN71	IEC 71 (B5)	14 Nm / 10.3 lb-ft	3,4 bar / 50 psi
VS6BN90/VS8BN90	IEC 90 (B5)	29 Nm / 21.4 lb-ft	3,4 bar / 50 psi
VS10BN100	IEC 100 (B5)	50 Nm / 36.9 lb-ft	3,4 bar / 50 psi



DIRECT CONTROLLED VANE AIR MOTORS

The GLOBE vane air motors can also be used in combination with a control valve which is directly mounted on top of the motor.

The control valves are available in two different types, the remote controlled and hand controlled valves. The control valves are proportional and allow the user to control the speed and direction of the air motor.

ADVANTAGES OF THE DIRECT CONTROLLED VANE AIR MOTORS ARE:

- Compact build because the control valve is mounted directly on the motor.
- Both remote and hand control possible.
- Proportional valves, allowing the user to have better control over the speed.
- The control valves are also certified according to the European Explosive Directive ATEX II cat. 2 G&D T5.
- Control valves have a biased option for normal speed in hoisting and reduced speed in lowering. This option is very common in winching applications.



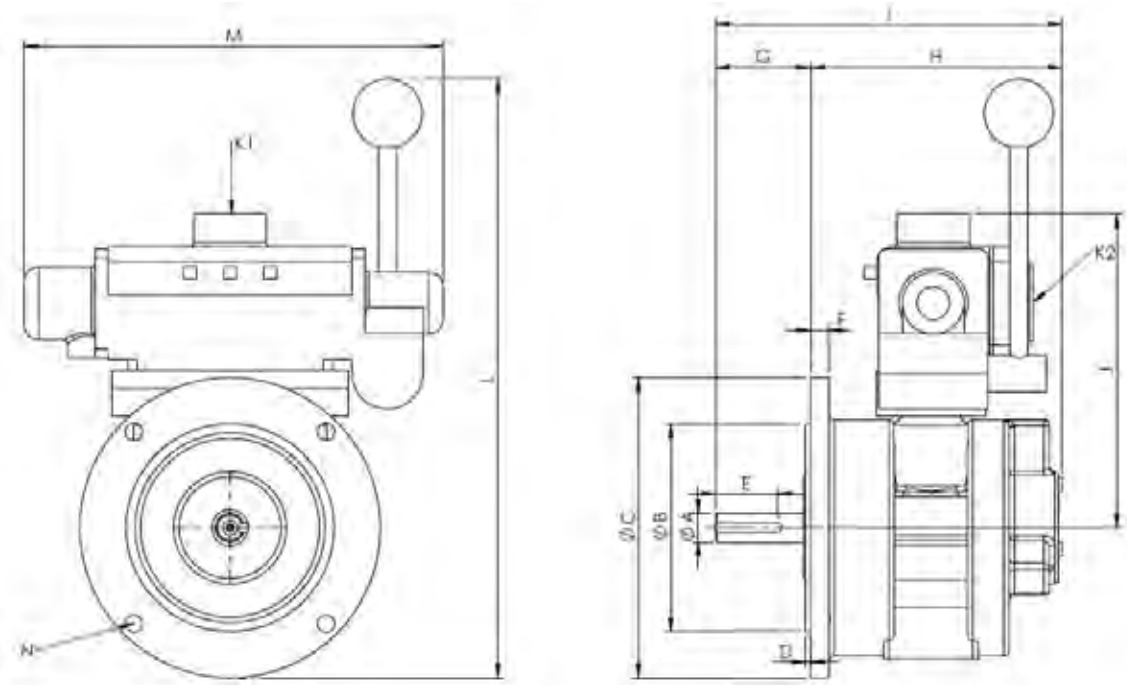

Motor with Hand controlled valve	A Ø	B Ø	C Ø	D	E	F	G	H
VA2C NEMA+ HCV110	15.875 (0.6250")	114.27 (4.499")	165 (6.5")	3 (0.12")	No key	10 (0.393")	52 (2.05")	117.25 (4.61")
	15.862 (0.6245")	114.20 (4.496")						
VA4C NEMA+ HCV210	15.875 (0.6250")	114.27 (4.499")	165 (6.5")	3 (0.12")	Key 3.18 (0.125") SQ 19 (0.75") Long	10 (0.393")	52 (2.05")	115 (4.53")
	15.862 (0.6245")	114.20 (4.496")						
VA6C NEMA+ HCV210	15.875 (0.6250")	114.27 (4.499")	165 (6.5")	3 (0.12")	Key 4.76 (0.188") SQ 36.5 (1.438") Long	10 (0.393")	52 (2.05")	138 (5.43")
	15.862 (0.6245")	114.20 (4.496")						
VA8C NEMA+ HCV310	22.23 (0.875")	114.30 (4.500")	165 (6.5")	3 (0.12")	Key 4.76 (0.188") SQ 36.5 (1.438") Long	10 (0.393")	54 (2.215")	161 (6.33")
	22.21 (0.874")	114.23 (4.498")						
VA10C NEMA+ HCV410	22.225 (0.875")	114.27 (4.499")	165 (6.5")	4 (0.16")	Key 4.76 (0.188") SQ 36.5 (1.438") Long	16 (0.63")	54 (2.215")	226 (8.89")
	22.212 (0.8745")	114.20 (4.496")						

Motor with Hand controlled valve	I	J	K1	K2	L	M	N
VA2C NEMA+ HCV110	169.25 (6.62")	152.5 (6.00")	Inlet ½" BSP	Outlet ½" BSP	356 (14.01")	231 (9.09")	4 holes - 3.8"-16-UNC equispaced on 149.23 (5.875") P.C.D.
	167 (6.57")	150.5 (5.92")	Inlet ¾" BSP	Outlet ¾" BSP	307.3 (12.10")	230 (9.05")	4 holes - 3.8"-16-UNC equispaced on 149.23 (5.875") P.C.D.
VA6C NEMA+ HCV210	190 (7.48")	172.5 (6.79")	Inlet ¾" BSP	Outlet ¾" BSP	329.3 (12.96")	230 (9.05")	4 holes - 3.8"-16-UNC equispaced on 149.23 (5.875") P.C.D.
	215 (8.47")	192 (7.56")	Inlet 1" BSP	Outlet 1" BSP	353.84 (13.93")	311 (12.24")	4 holes - 3.8"-16-UNC equispaced on 149.23 (5.875") P.C.D.
VA10C NEMA+ HCV410	280 (11.03")	218.7 (8.61")	Inlet 1 ¼" BSP	Outlet 1 ¼" BSP	379.93 (14.96")	313 (12.32")	4 holes - 3.8"-16-UNC equispaced on 149.23 (5.875") P.C.D.

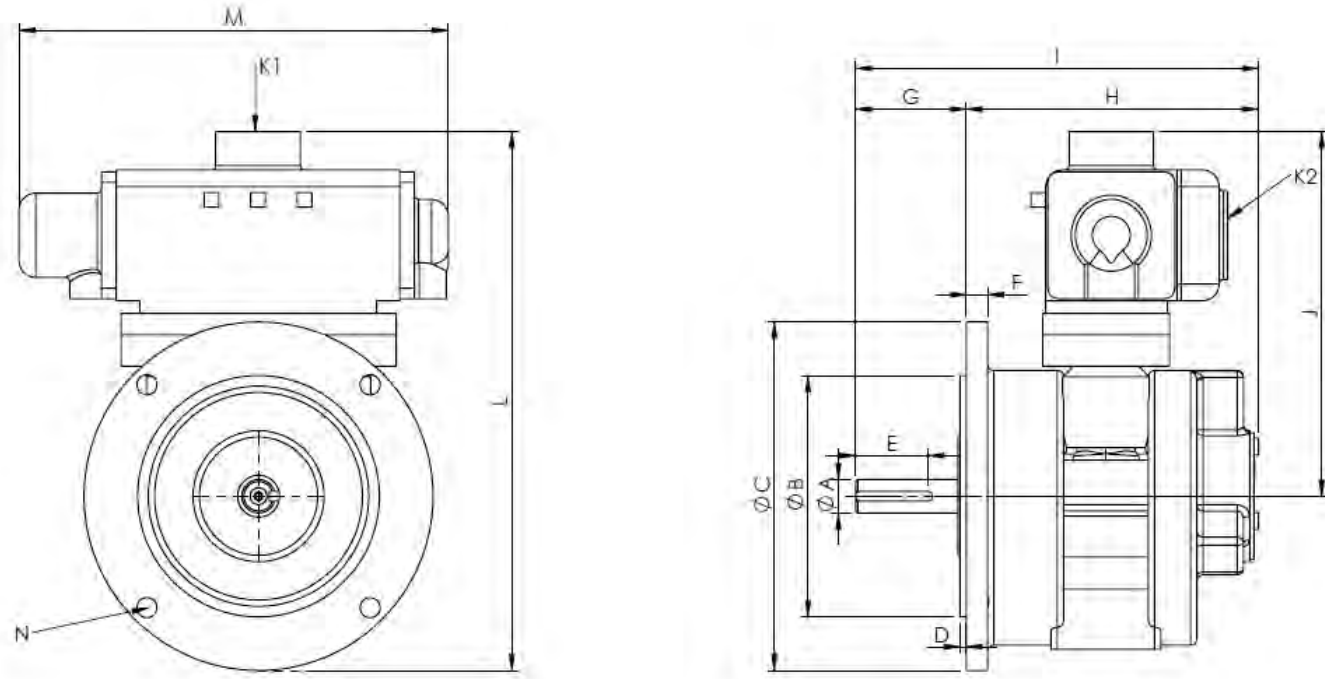

Motor with Remote controlled valve	A Ø	B Ø	C Ø	D	E	F	G	H
VA2C NEMA+RCV110	15.875 (0.6250")	114.27 (4.499")	165 (6.5")	3 (0.12")	No key	10 (0.393")	52 (2.05")	109.25 (4.30")
	15.862 (0.6245")	114.20 (4.496")						
VA4C NEMA+RCV210	15.875 (0.6250")	114.27 (4.499")	165 (6.5")	3 (0.12")	Key 3.18 (0.125") SQ	10 (0.393")	52 (2.05")	109.25 (4.30")
	15.862 (0.6245")	114.20 (4.496")			19 (0.75") Long			
VA6C NEMA+RCV210	15.875 (0.6250")	114.27 (4.499")	165 (6.5")	3 (0.12")	Key 4.76 (0.188") SQ	10 (0.393")	52 (2.05")	138 (5.43")
	15.862 (0.6245")	114.20 (4.496")			36.5 (1.438") Long			
VA8C NEMA+RCV310	22.23 (0.875")	114.30 (4.500")	165 (6.5")	3 (0.12")	Key 4.76 (0.188") SQ	10 (0.393")	54 (2.215")	161 (6.33")
	22.21 (0.874")	114.23 (4.498")			36.5 (1.438") Long			
VA10C NEMA+RCV410	22.225 (0.875")	114.27 (4.499")	165 (6.5")	4 (0.16")	Key 4.76 (0.188") SQ	16 (0.63")	54 (2.215")	226 (8.89")
	22.212 (0.8745")	114.20 (4.496")			36.5 (1.438") Long			

Motor with Remote controlled valve	I	J	K1	K2	L	M	N
VA2C NEMA+RCV110	161.25 (6.35")	152.5 (6.00")	Inlet ½"BSP	Outlet ½" BSP	235 (9.25")	203 (7.99")	4 holes - 3.8"-16- UNC equispaced on 149.23 (5.875") P.C.D.
VA4C NEMA+RCV210	161.25 (6.35")	150.5 (5.92")	Inlet ¾"BSP	Outlet ¾"BSP	233 (9.17")	203 (7.99")	4 holes - 3.8"-16- UNC equispaced on 149.23 (5.875") P.C.D.
VA6C NEMA+RCV210	190 (7.48")	172.5 (6.79")	Inlet ¾"BSP	Outlet ¾"BSP	255 (10.04")	203 (7.99")	4 holes - 3.8"-16- UNC equispaced on 149.23 (5.875") P.C.D.
VA8C NEMA+RCV310	215 (8.47")	193 (7.60")	Inlet 1"BSP	Outlet 1"BSP	275.5 (10.84")	275 (10.83")	4 holes - 3.8"-16- UNC equispaced on 149.23 (5.875") P.C.D.
VA10C NEMA+RCV410	280 (11.03")	218.7 (8.61")	Inlet 1 ¼" BSP	Outlet 1 ¼" BSP	307.5 (12.10")	278 (10.94")	4 holes - 3.8"-16- UNC equispaced on 149.23 (5.875") P.C.D.

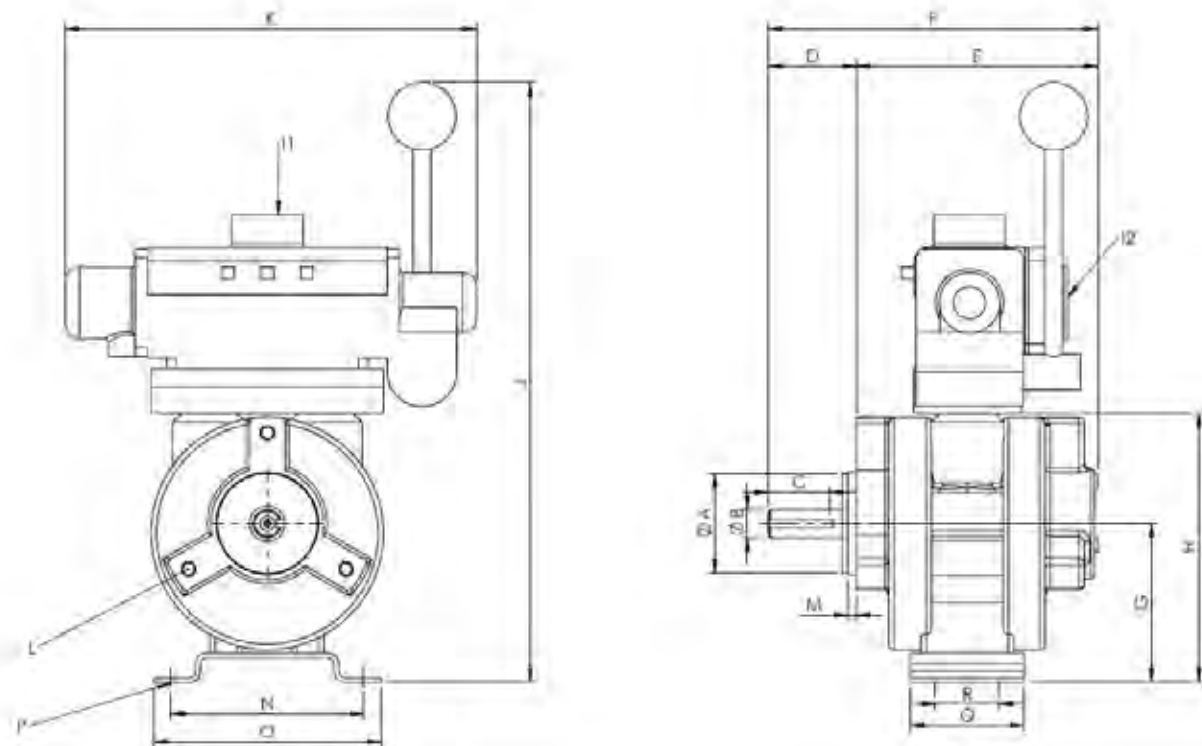

Motor with Hand controlled valve	A Ø	B Ø	C	D	E	F	G
VA2J&X+HCV110	44.42 (1.749")	12.7 (0.5000")	No key	44.5 (1.75")	117,75 (4.635")	148,25 (5.836")	88,85 (3.5")
	44.38 (1.747")	12.687 (0.4995")					
VA4J&X+HCV210	44.42 (1.749")	12.7 (0.5000")	Key 3.18 (0.125") SQ 19 (0.75") Long	44.5 (1.75")	101 (3.976")	145,5 (5.728")	89 (3.504")
	44.38 (1.747")	12.687 (0.4995")					
VA6J&X+HCV210	57.15 (2.250")	15.875 (0.625")	Key 4.76 (0.188") SQ 36.5 (1.438") Long	49.2 (1.94")	135 (5.31")	184,2 (7.252")	88,9 (3.5")
	57.10 (2.248")	15.862 (0.624")					
VA8J&X+HCV310	76.2 (3.00")	19.06 (0.750")	Key 28 (1.10")	53 (2.09")	149 (5.866")	202 (7.97")	89 (3.504")
	76.1 (2.996")	19.04 (0.749")					
VA10J&X+HCV410	98.42 (3.875")	28.575 (1.1250")	Key 6.35 (0.250") SQ 44.5 (1.75") Long	103 (4.06")	199 (7.834")	302 (11.88")	101.6 (4.000")
	98.37 (3.873")	28.560 (1.1244")					101.3 (3.988")

Motor with Hand controlled valve	H	I1	I2	J	K	L
VA2J&X+HCV110	140,35 (5.53")	Inlet ½"BSP	Outlet ½"BSP	362,35 (14.265")	231 (9.09")	3 holes ¼"-20 UNC x 12 (0.47") Deep spaced on 63.5 (2.5") P.C.D.
VA4J&X+HCV210	138,5 (5.452")	Inlet ¾"BSP	Outlet ¾"BSP	314 (12.362")	230 (9.05")	3 holes ¼"-20 UNC x 12 (0.47") Deep spaced on 63.5 (2.5") P.C.D.
VA6J&X+HCV210	150,5 (5.94")	Inlet ¾"BSP	Outlet ¾"BSP	335 (13.188")	230 (9.05")	3 holes 5/16"-18 UNC X 20 (25/32") deep equispaced on 101.6 (4.000") P.C.D.
VA8J&X+HCV310	160 (6.31")	Inlet 1" BSP	Outlet 1" BSP	360 (14.173")	311 (12.24")	4 holes tapped 3/8"-16 UNC x 16 (0.63") deep equispaced on 98.43 (3.875") P.C.D.
VA10J&X+HCV410	187 (7.38")	Inlet 1 ¼" BSP	Outlet 1 ¼"BSP	393 (15.472")	313 (12.32")	4 holes 7/16"-14 UNC x 16 (0.63") deep equispaced on 123.8 (4.874") P.C.D.

Motor with Hand controlled valve	M	N	O	P	Q	R
VA2J&X+HCV110	16 (0.63")	76 (3.0")	90 (3.54")	4 mounting holes Ø7 (0.28")	38 (1.5")	24 (0.94")
VA4J&X+HCV210	16 (0.63")	76 (3.0")	90 (3.54")	4 mounting holes Ø7 (0.28")	38 (1.5")	24 (0.94")
VA6J&X+HCV210	5 (0.2")	108 (4.250")	127 (5.00")	4 mounting holes Ø9 (11/32")	63.5 (2.50")	44.4 (1.75")
VA8J&X+HCV310	x	114.3 (4.50")	134 (5.26")	4 mounting holes Ø9 (11/32")	72 (2.84")	51 (2.00")
VA10J&X+HCV410	x	171.45 (6.750")	200 (7.88")	4 mounting holes Ø10.3 (4.06")	102 (4.00")	69.85 (2.750")

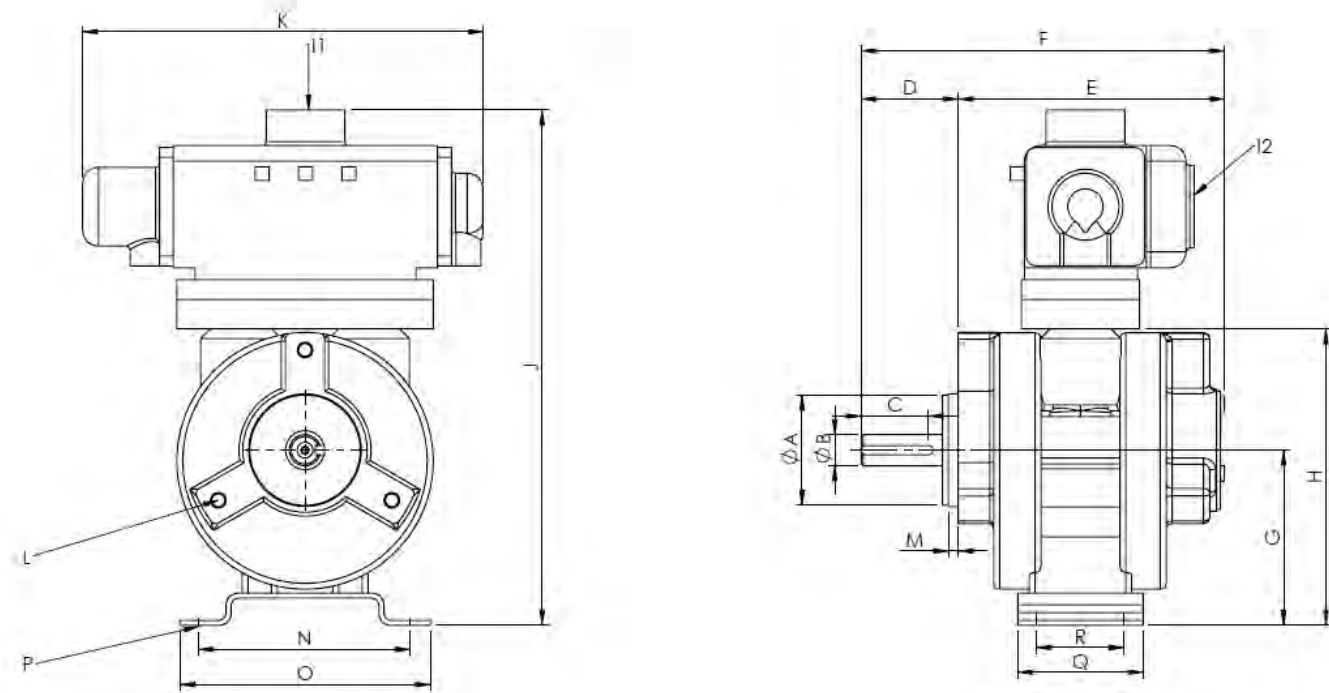

Motor with Remote controlled valve	A ∅	B ∅	C	D	E	F	G
VA2J&X+RCV110	44.42 (1.749")	12.7 (0.5000")	No key	44.5 (1.75")	95.75 (3.769")	140.25 (5.521")	88.85 (3.5")
	44.38 (1.747")	12.687 (0.4995")					
VA4J&X+RCV210	44.42 (1.749")	12.7 (0.5000")	Key 3.18 (0.125") SQ 19 (0.75") Long	44.5 (1.75")	95.25 (3.75")	139.75 (5.502")	89 (3.504")
	44.38 (1.747")	12.687 (0.4995")					
VA6J&X+RCV210	57.15 (2.250")	15.875 (0.625")	Key 4.76 (0.188") SQ 36.5 (1.438") Long	49.2 (1.94")	135 (5.31")	184.2 (7.251")	88.9 (3.5")
	57.10 (2.248")	15.862 (0.624")					
VA8J&X+RCV310	76.2 (3.00")	19.06 (0.750")	Key 28 (1.10")	53 (20.9")	149 (5.866")	202 (7.952")	89 (3.504")
	76.1 (2.996")	19.04 (0.749")					
VA10J&X+RCV410	98.42 (3.875")	28.575 (1.125")	Key 6.35 (0.250") SQ 44.5 (1.75") Long	103 (4.06")	199 (7.834")	302 (11.89")	101.6 (4.000")
	98.37 (3.873")	28.560 (1.124")					101.3 (3.988")

Motor with Remote controlled valve	H	I1	I2	J	K	L
VA2J&X+RCV110	140.35 (5.525")	Inlet ½"BSP	Outlet ½"BSP	241.35 (9.502")	203 (7.992")	3 holes ¼"-20 UNC x 12 (0.47") Deep spaced on 63.5 (2.5") P.C.D.
VA4J&X+RCV210	138.5 (5.452")	Inlet ¾"BSP	Outlet ¾"BSP	239.4 (9.425")	203 (7.992")	3 holes ¼"-20 UNC x 12 (0.47") Deep spaced on 63.5 (2.5") P.C.D.
VA6J&X+RCV210	150.5 (5.94")	Inlet ¾"BSP	Outlet ¾"BSP	261.4 (10.291")	203 (7.992")	3 holes 5/16"-18 UNC X 20 (25/32") deep equispaced on 101.6 (4.000") P.C.D.
VA8J&X+RCV310	160 (6.31")	Inlet 1" BSP	Outlet 1"BSP	282 (11.102")	275 (10.826")	4 holes tapped 3/8"-16 UNC x 16 (0.63") deep equispaced on 98.43 (3.875") P.C.D.
VA10J&X+RCV410	187 (7.38")	Inlet 1 ¼" BSP	Outlet 1 ¼"BSP	320.3 (12.610")	278 (10.944")	4 holes 7/16"-14 UNC x 16 (0.63") deep equispaced on 123.8 (4.874") P.C.D.

Motor with Remote controlled valve	M	N	O	P	Q	R
VA2J&X+RCV110	16 (0.63")	76 (3.0")	90 (3.54")	4 mounting holes ∅7 (0.28")	38 (1.5")	24 (0.94")
VA4J&X+RCV210	16 (0.63")	76 (3.0")	90 (3.54")	4 mounting holes ∅7 (0.28")	38 (1.5")	24 (0.94")
VA6J&X+RCV210	5 (0.2")	108 (4.250")	127 (5.000")	4 mounting holes ∅9 (11/23")	63.5 (2.50")	44.4 (1.75")
VA8J&X+RCV310	x	114.3 (4.50")	134 (5.26")	4 mounting holes ∅9 (11/23")	72 (2.84")	51 (2.00")
VA10J&X+RCV410	x	171.45 (6.750")	200 (7.88")	4 mounting holes ∅10.3 (4.06")	102 (4.00")	69.85 (2.750")

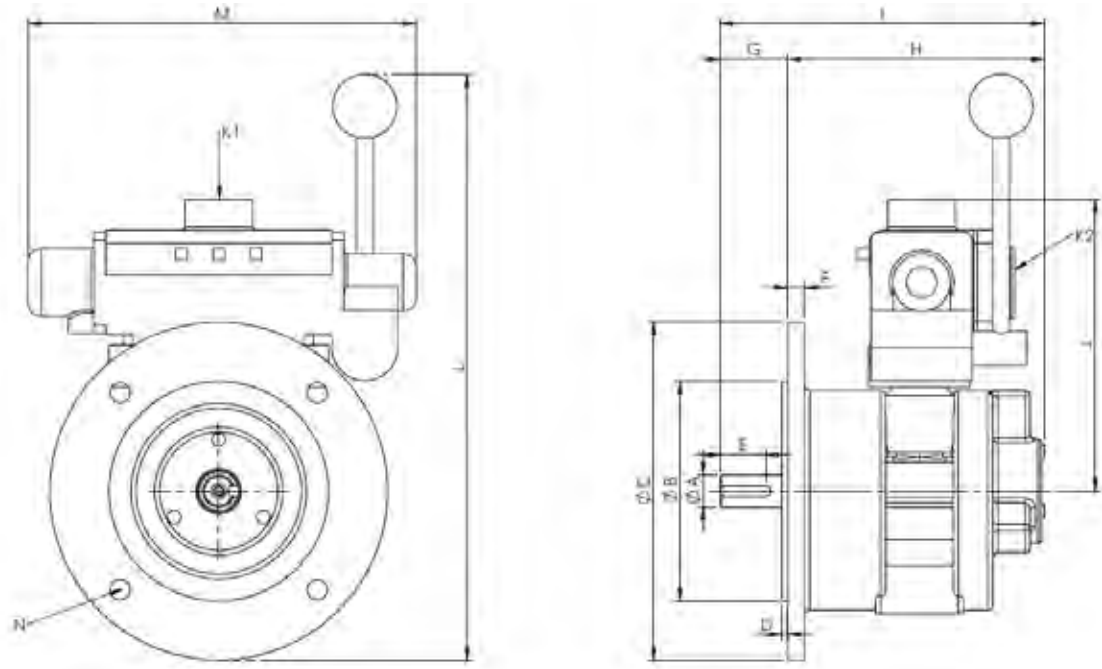

Motor with Hand controlled valve	A Ø	B Ø	C Ø	D	E	F
VS2C+HCV110	14.012 (0.5516")	110.000 (4.3307")	160 (6.30")	3.5 (0.14")	Key 5 (0.197") Square X 20 (0.78") Long rounded ends Tapped hole in shaft. M5X15 (0.59") Deep.	9 (0.35")
	14.001 (0.5512")	109.946 (4.3286")				
VS4C+HCV210	14.012 (0.5516")	110.000 (4.3307")	160 (6.30")	3.5 (0.14")	Key 5 (0.197") Square X 20 (0.78") Long rounded ends Tapped hole in shaft. M5X15 (0.59") Deep.	9 (0.35")
	14.001 (0.5512")	109.946 (4.3286")				
VS6C+HCV210	19.009 (0.7484")	130.000 (5.1181")	200 (7.87")	3.5 (0.14")	Key 6 (0.236") Square X 30 (1.18") Long rounded at one end. Tapped hole in shaft M6X15 (0.59") Deep.	10 (0.39")
	18.996 (0.7479")	129.937 (5.1156")				
VS8C+HCV310	24.009 (0.9452")	130.000 (5.1181")	200 (7.87")	3.5 (0.14")	Key 8 (0.315") Square X 7 (0.276") Deep X 36 (1.42") Long rounded ends. Tapped hole in shaft M8X20 (0.79") Deep.	10 (0.39")
	23.996 (0.9447")	129.937 (5.1156")				
VS10C+HCV410	28.009 (1.1027")	180.000 (7.0866")	250 (9.84")	4 (0.16")	Key 8 (0.315") Square X 7 (0.276") Deep X 45 (1.77") Long rounded ends. Tapped hole in shaft M10X25 (1") Deep.	11 (0.43")
	27.996 (1.1022")	179.937 (7.0841")				

Motor with Hand controlled valve	G	H	I	J	K1	K2	L	M	N
VS2C+HCV110	30 (1.18")	117.25 (4.61")	147.25 (5.80")	152.5 (6.00")	Inlet ½"BSP	Outlet ½"BSP	353.5 (13.92")	231 (9.09")	4 holes Ø9 (0.35") equispaced on 130 (5.118") P.C.D.
VS4C+HCV210	30 (1.18")	114.5 (4.51")	144.5 (5.69")	150.5 (5.92")	Inlet ¾"BSP	Outlet ¾"BSP	304.8 (12.00")	230 (9.05")	4 holes Ø9 (0.35") equispaced on 130 (5.118") P.C.D.
VS6C+HCV210	40 (1.57")	152 (5.98")	192 (7.56")	172.5 (6.79")	Inlet ¾"BSP	Outlet ¾"BSP	346.8 (13.65")	230 (9.05")	4 holes Ø12 (0.47") Equispaced on 165 (6.496") P.C.D.
VS8C+HCV310	50 (1.97")	155 (6.10")	205 (8.07")	192 (7.56")	Inlet 1"BSP	Outlet 1"BSP	371.3 (14.62")	311 (12.24")	4 holes Ø12 (0.47") Equispaced on 165 (6.496") P.C.D.
VS10C+HCV410	60 (2.36")	225 (8.86")	305 (12.01")	218.7 (8.61")	Inlet 1 ¼"BSP	Outlet 1 ¼"BSP	416.1 (16.38")	313 (12.32")	4 holes Ø15 (0.59") Equispaced on 215 (8.465") P.C.D.

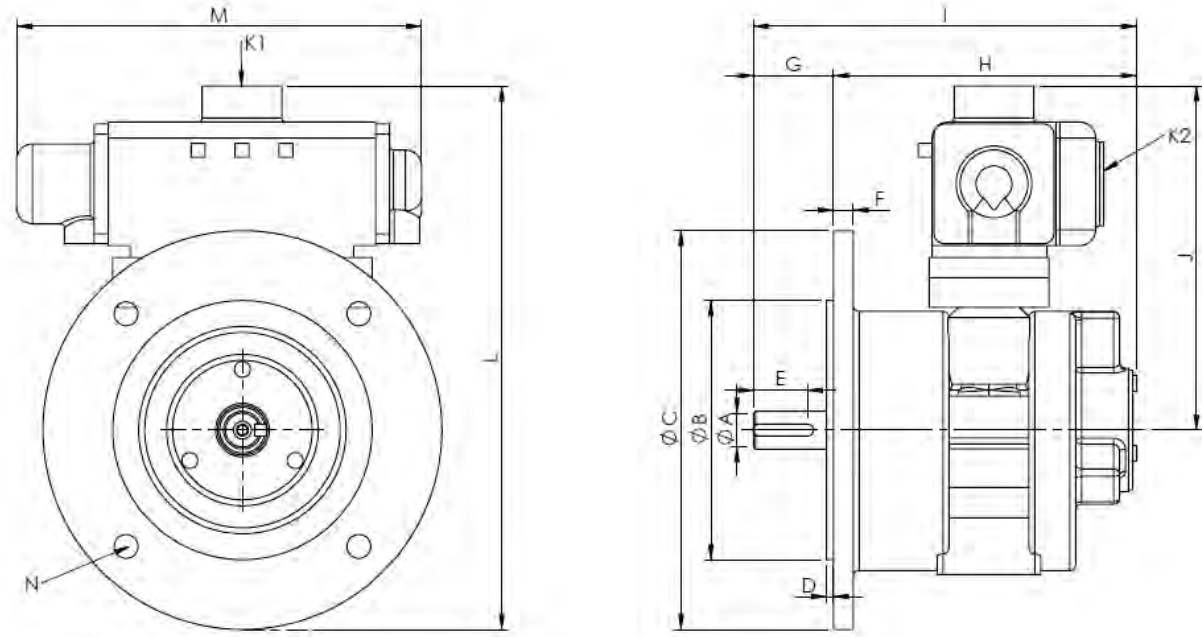

Motor with Remote controlled valve	A Ø	B Ø	C Ø	D	E	F	G	H
VS2C+RCV110	14.012 (0.5516")	110.000 (4.3307")	160 (6.30")	3.5 (0.14")	Key 5 (0.197") Square X 20 (0.78") Long rounded ends	9 (0.35")	30 (1.18")	109.25 (4.30")
	14.001 (0.5512")	109.946 (4.3286")			Tapped hole in shaft. M5X15 (0.59") Deep.			
VS4C+RCV210	14.012 (0.5516")	110.000 (4.3307")	160 (6.30")	3.5 (0.14")	Key 5 (0.197") Square X 20 (0.78") Long rounded ends	9 (0.35")	30 (1.18")	108.75 (4.28")
	14.001 (0.5512")	109.946 (4.3286")			Tapped hole in shaft. M5X15 (0.59") Deep.			
VS6C+RCV210	19.009 (0.7484")	130.000 (5.1181")	200 (7.87")	3.5 (0.14")	Key 6 (0.236") Square X 30 (1.18") Long rounded at one end. Tapped hole in shaft M6X15 (0.59") Deep.	10 (0.39")	40 (1.57")	152 (5.98")
	18.996 (0.7479")	129.937 (5.1156")						
VS8C+RCV310	24.009 (0.9452")	130.000 (5.1181")	200 (7.87")	3.5 (0.14")	Key 8 (0.315") Square X 7 (0.276") Deep X 36 (1.42") Long rounded ends. Tapped hole in shaft M8X20 (0.79") Deep.	10 (0.39")	50 (1.97")	155 (6.10")
	23.996 (0.9447")	129.937 (5.1156")						
VS10C+RCV410	28.009 (1.1027")	180.000 (7.0866")	250 (9.84")	4 (0.16")	Key 8 (0.315") Square X 7 (0.276") Deep X 45 (1.77") Long rounded ends. Tapped hole in shaft M10X25 (1") Deep.	11 (0.43")	60 (2.36")	225 (8.86")
	27.996 (1.1022")	179.937 (7.0841")						

Motor with Remote controlled valve	I	J	K1	K2	L	M	N
VS2C+RCV110	139.25 (5.48")	152.5 (6.00")	Inlet ½"BSP	Outlet ½"BSP	232.5 (9.15")	203 (7.99")	4 holes Ø9 (0.35") equispaced on 130 (5.118") P.C.D.
VS4C+RCV210	138.75 (5.46")	150.5 (5.92")	Inlet ¾"BSP	Outlet ¾"BSP	230.5 (9.07")	203 (7.99")	4 holes Ø9 (0.35") equispaced on 130 (5.118") P.C.D.
VS6C+RCV210	192 (7.56")	172.5 (6.79")	Inlet ¾"BSP	Outlet ¾"BSP	275.5 (10.84")	203 (7.99")	4 holes Ø12 (0.47") Equispaced on 165 (6.496") P.C.D.
VS8C+RCV310	205 (8.07")	193 (7.59")	Inlet 1"BSP	Outlet 1"BSP	293 (11.53")	275 (10.82")	4 holes Ø12 (0.47") Equispaced on 165 (6.496") P.C.D.
VS10C+RCV410	305 (12.01")	218.7 (8.61")	Inlet 1 ¼"BSP	Outlet 1 ¼"BSP	343.7 (13.53")	278 (10.95")	4 holes Ø15 (0.59") Equispaced on 215 (8.465") P.C.D.

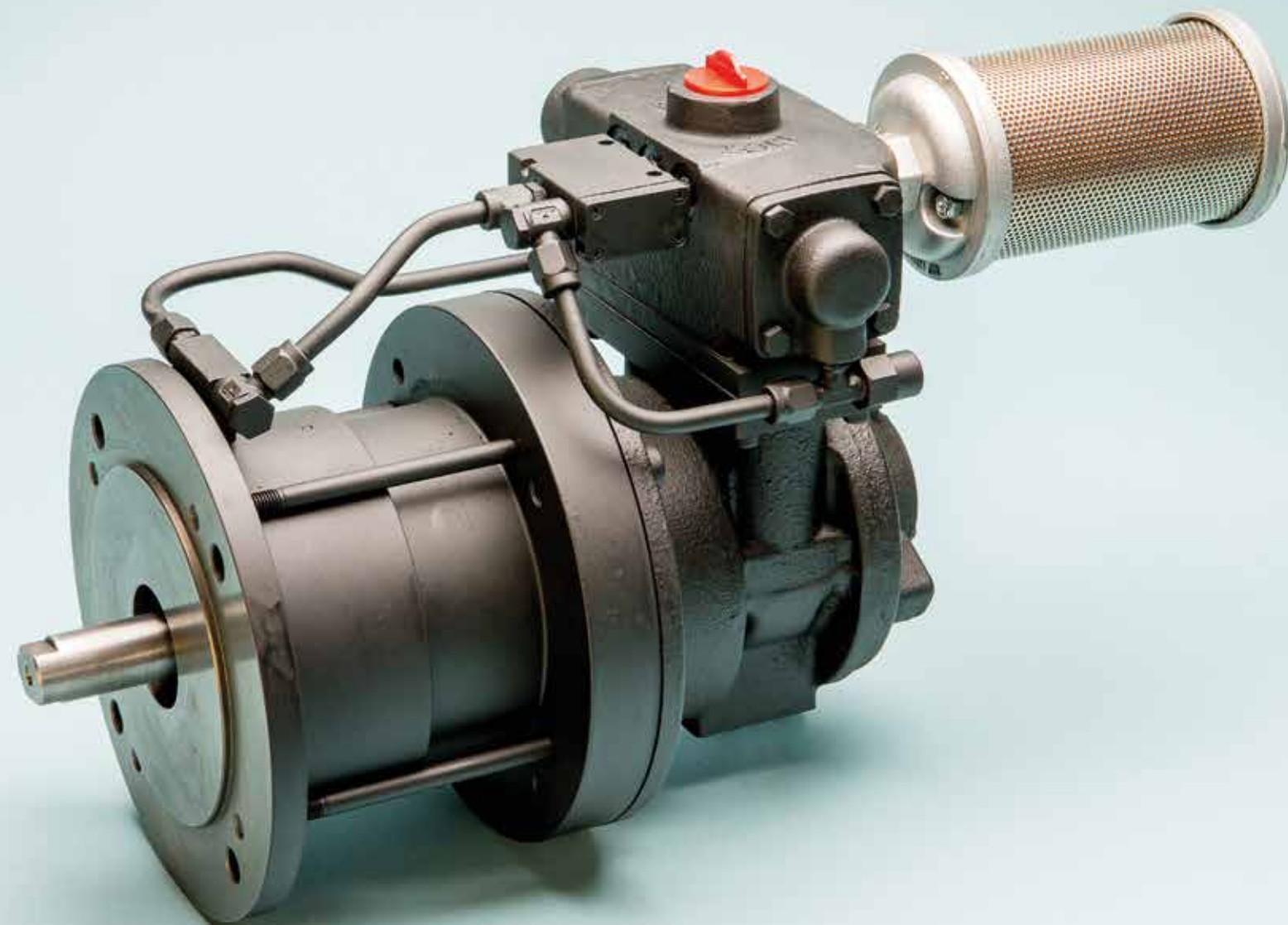

AIR MOTOR UNIT FOR WINCHES

APPLICATION

GLOBE has developed specially for winch and hoist applications a braked air motor set. The unit has a robust GLOBE vane motor with an fail safe BN brake and a proportional directional control valve.

The vane motor is of robust design and very good for harsh conditions. The BN brake is a spring loaded, air release failsafe brake. The holding torque is 1,5 to 2 times the maximum torque of the motor.

On top of the motor a proportional control valve is mounted. It can be a proportional remote control valve or a proportional hand control valve. The proportional valve controls the direction and speed of the motor. The brake is released with pipelines from the proportional control valve. The unit is designed that the motor is under pressure before the brake is released.

As standard the proportional valves can be supplied with either Equal Power or Biased Power spools, the latter is suitable for hoisting applications. The motor will have maximum power in lifting and reduced power in lowering. Because of the biased valve the load will not pull the motor in over speed in lowering direction.

The air motor unit confirms to European Standard NEN-EN 13463-1 for non-electrical equipment for explosive atmospheres ATEX GROUP II cat 2 GDc T3.

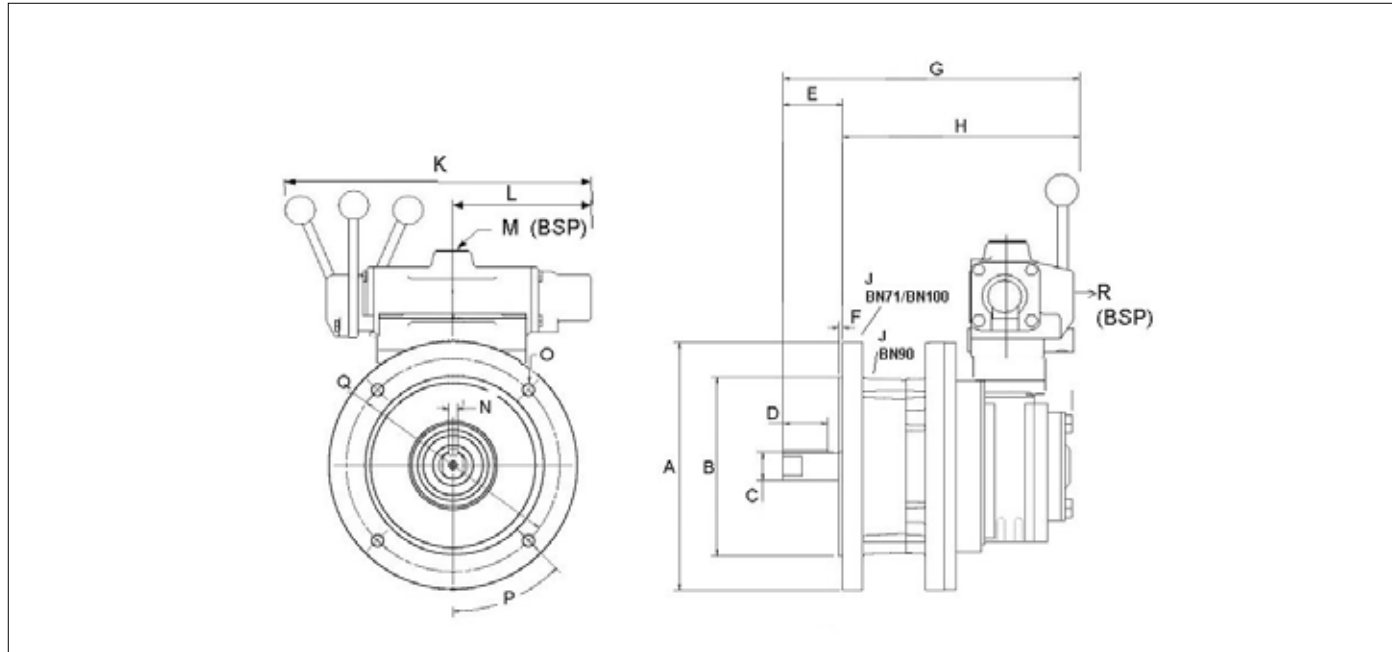

Motor with Brake with Hand Control, including valve and piping to control brake (not displayed).

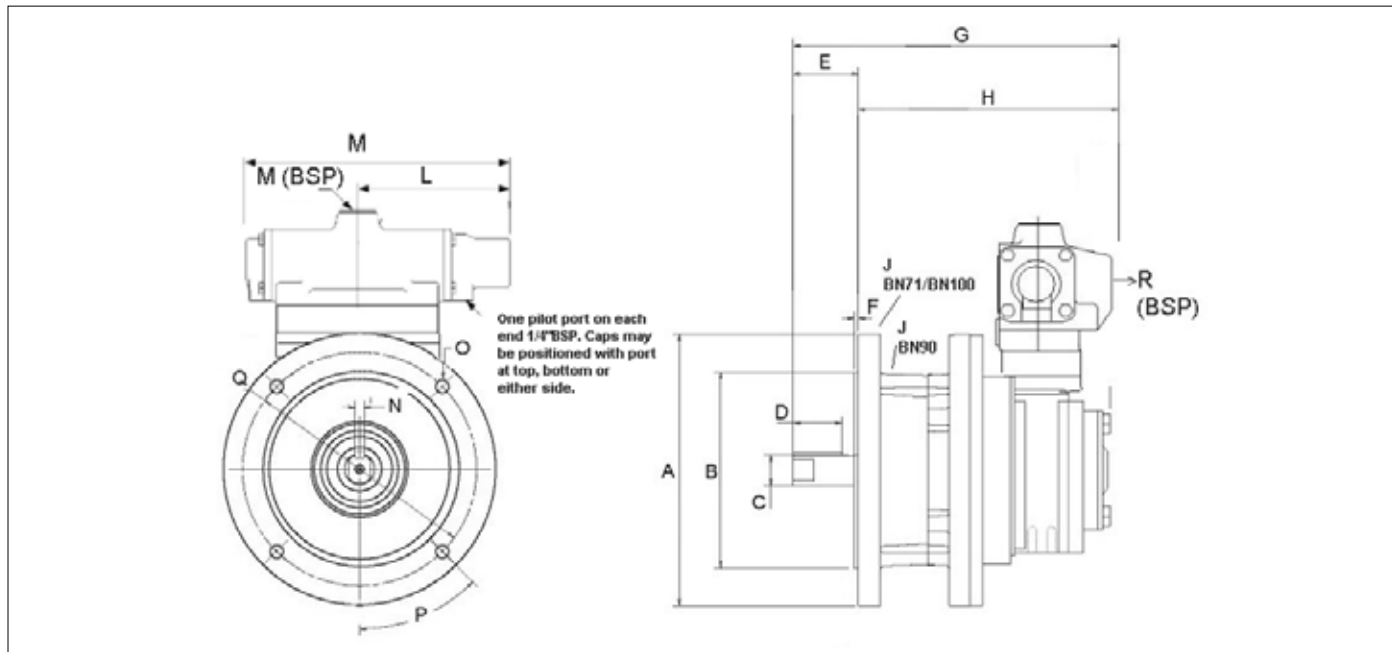

Motor with Brake with Remote Control, including valve and piping to control brake (not displayed).

	A	B	C	D	E	F	G	H	J	K
VS4BN71H2 VS4BN71R2	160 (6.29")	110 (4.33")	14 (0.55")	20 (0.78")	30 (1.18")	3.5 (0.13")	240 (9.45")	210 (8.26")	1/8	270 (10.62")
VS6BN90H2 VS6BN90R2	200 (7.87")	130 (5.12")	24 (0.94")	30 (1.18")	50 (1.96")	3.5 (0.13")	347 (13.66")	297 (11.69")	1/8	270 (10.62")
VS8BN90H3 VS8BN90R3	200 (7.87")	130 (5.12")	24 (0.94")	30 (1.18")	50 (1.96")	3.5 (0.13")	350 (13.78")	300 (11.81")	1/8	365 (14.37")
VS10BN100H4 VS10BN100R4	250 (7.87")	180 (7.08")	28 (1.10")	50 (1.96")	60 (2.36")	4 (0.16")	459 (18.07")	399 (15.71")	1/8	365 (14.37")

	L	M	N	O Ø	P	Q	R
VS4BN71H2 VS4BN71R2	118 (4.64")	3/4	5 (0.19")	10 (0.39")	45°	110h7 (4.33")	3/4
VS6BN90H2 VS6BN90R2	118 (4.64")	3/4	8 (0.31")	12 (0.47")	45°	130h7 (5.12")	3/4
VS8BN90H3 VS8BN90R3	160 (6.29")	1	8 (0.31")	12 (0.47")	45°	130h7 (5.12")	1
VS10BN100H4 VS10BN100R4	160 (6.29")	1 1/4	10 (0.39")	14 (0.55")	45°	180h7 (7.08")	1 1/4

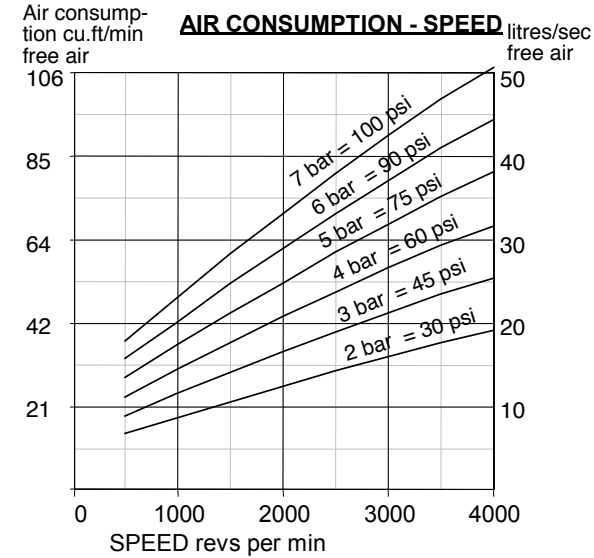
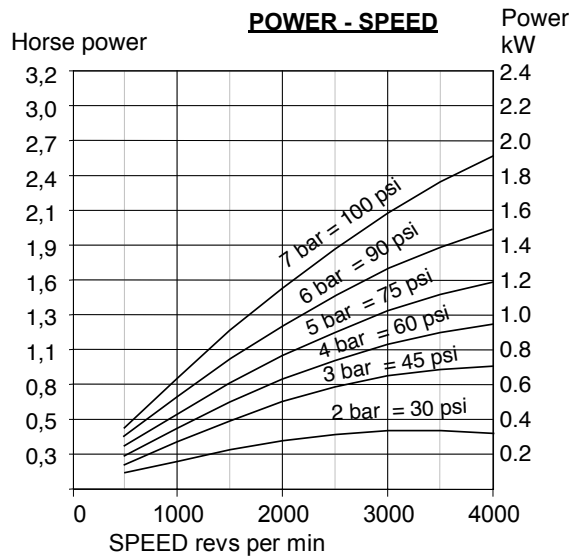
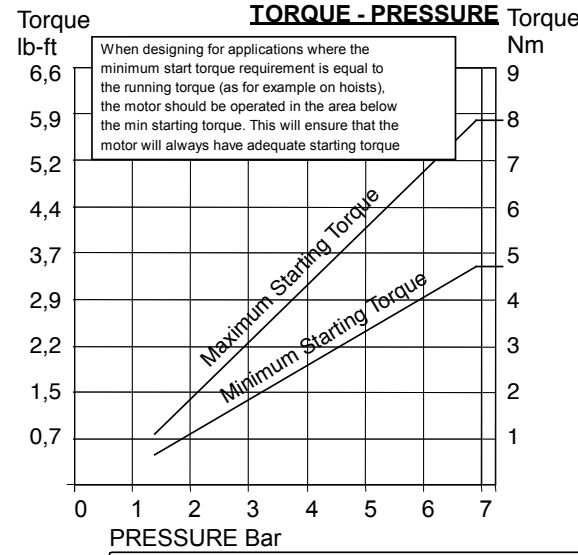
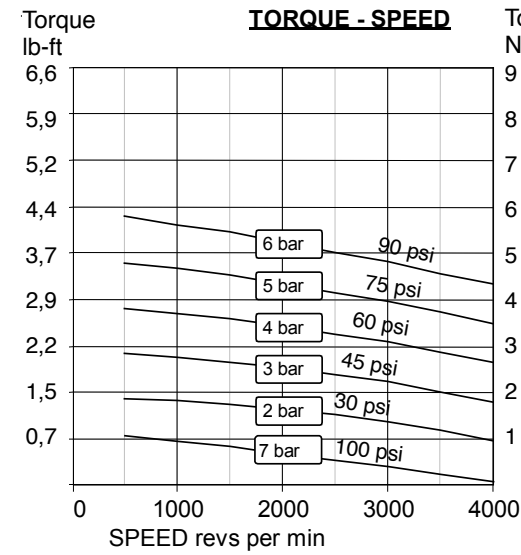

Muffler supplied with motor.

Motor is reversible.

ATTITUDE

The motor can be operated in all positions.

Maximum temperature -20°C to +80°C (-4°F to +176°F).

Max. Overhung Force on motor shaft 170n (40 lbf.)

Axial loads should be kept to a minimum.

AIRLINE FILTRATION AND LUBRICATION

Use 64 micron filtration or better. Choose a lubricator suitable for the flow required. Prior to initial start-up, inject oil into the inlet port.

Lubricator drop rate 4-5 drops/minute continuous operation

Lubricator drop rate 9-12 drops/minute intermittent operation

MAXIMUM CONTINUOUS SPEED 4000 RPM

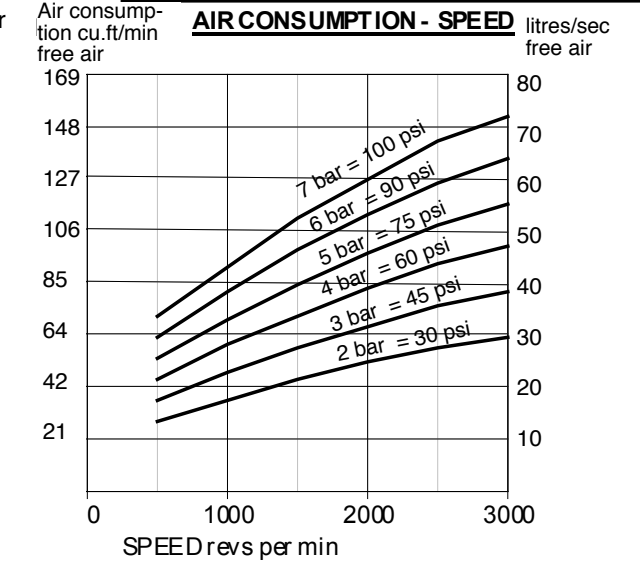
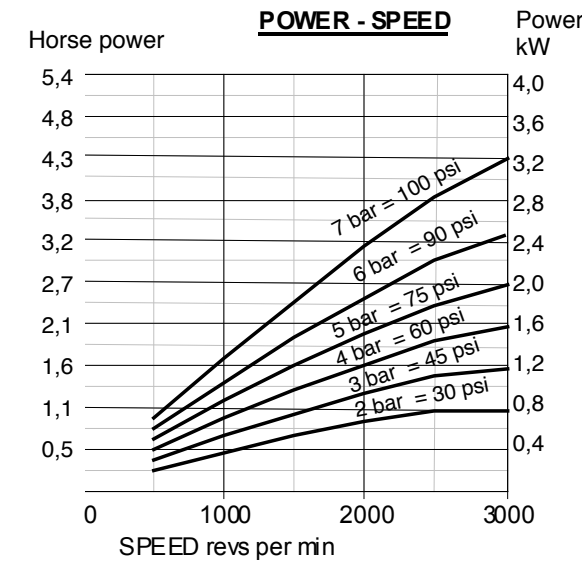
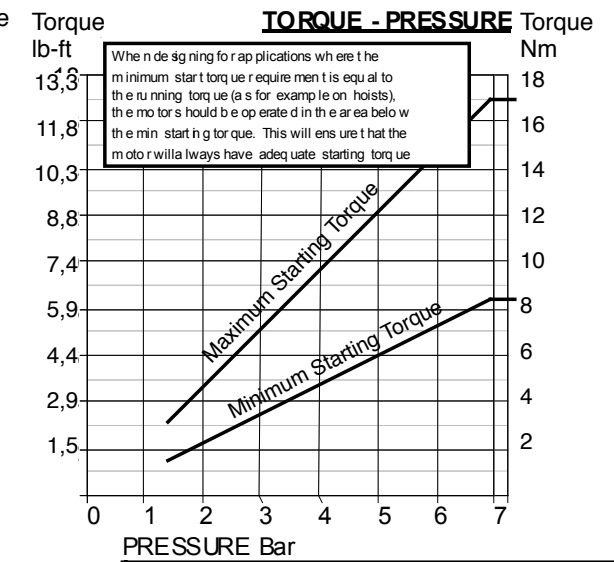
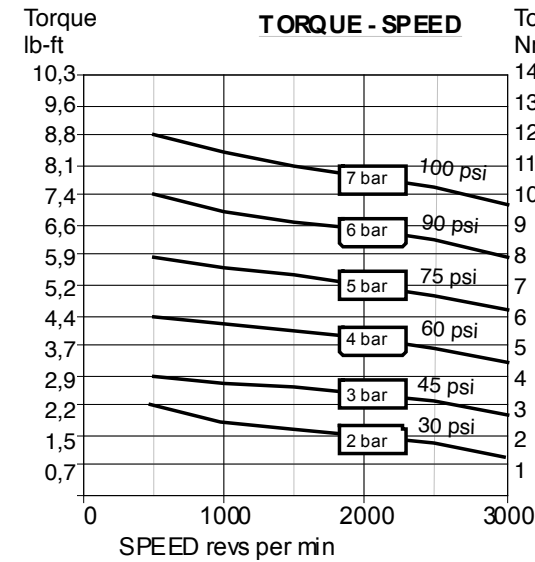

Muffler supplied with motor.

Motor is reversible.

ATTITUDE

The motor can be operated in all positions.

Maximum temperature -20°C to +80°C (-4°F to +176°F).

Max. Overhung Force on motor shaft 300n (70 lbf.)

Axial loads should be kept to a minimum.

AIRLINE FILTRATION AND LUBRICATION

Use 64 micron filtration or better. Choose a lubricator suitable for the flow required. Prior to initial start-up, inject oil into the inlet port.

Lubricator drop rate 5-6 drops/minute continuous operation

Lubricator drop rate 10-12 drops/minute intermittent operation

MAXIMUM CONTINUOUS SPEED 3000 RPM

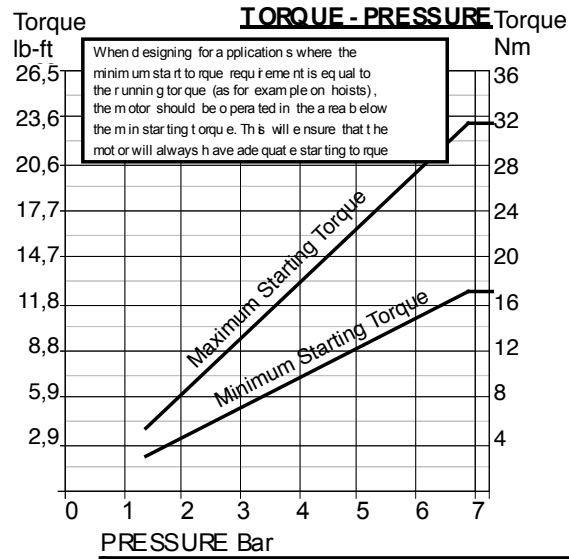
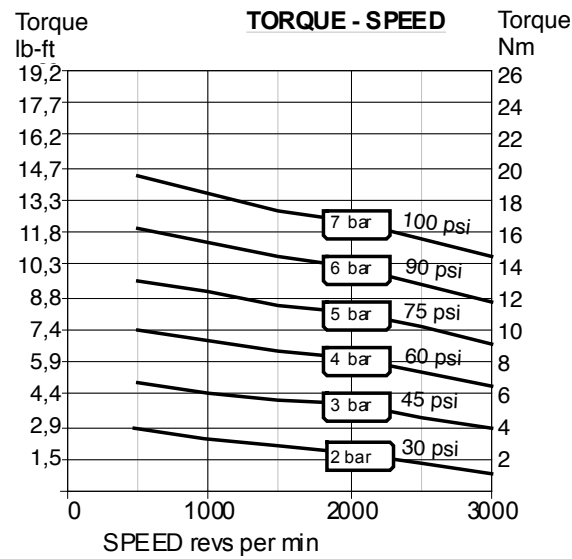

When designing for applications where the minimum starting torque requirement is equal to the running torque (as for example on hoists), the motor should be operated in the area below the minimum starting torque. This will ensure that the motor will always have adequate starting torque.

A pressure regulator should be used to control the air pressure to the motor, to limit the maximum output torque applied to the driven assembly.

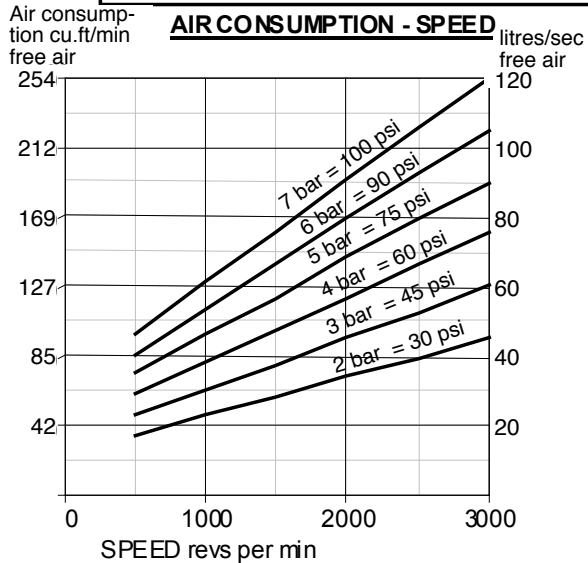
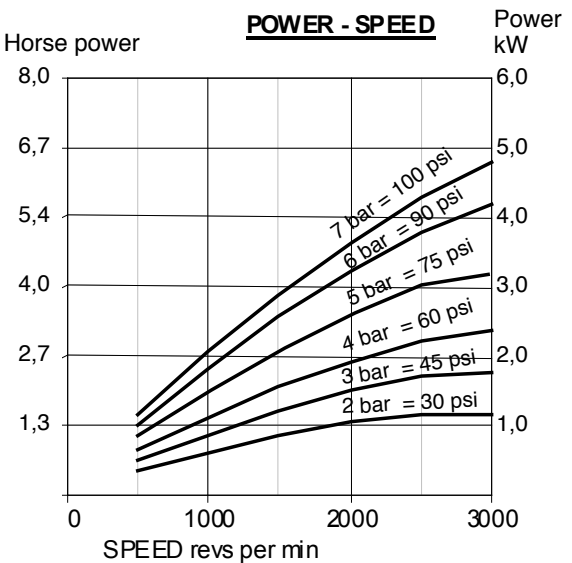

Muffler supplied with motor.

Motor is reversible.

ATTITUDE

The motor can be operated in all positions.

Maximum temperature -20°C to +80°C

(-4°F to +176°F).

Max. Overhung Force on motor shaft 620N (140 lbf.)

Axial loads should be kept to a minimum.

AIRLINE FILTRATION AND LUBRICATION

Use 64 micron filtration or better. Choose a lubricator suitable for the flow required. Prior to initial start-up, inject oil into the inlet port.

Lubricator drop rate 6-7 drops/minute continuous operation

Lubricator drop rate 12-15 drops/minute intermittent operation

MAXIMUM CONTINUOUS SPEED 3000 RPM

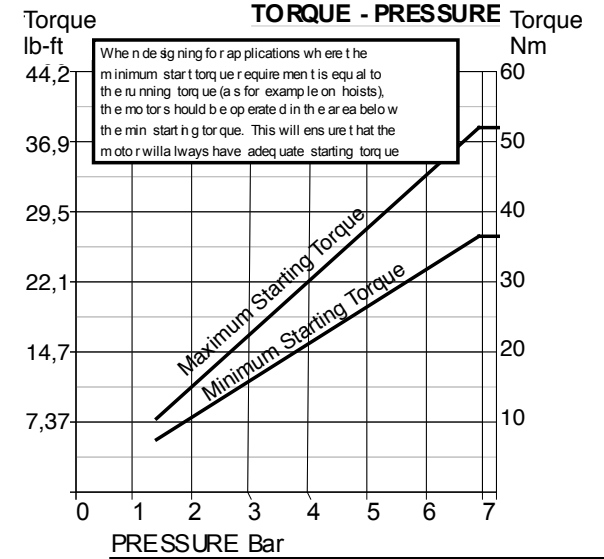
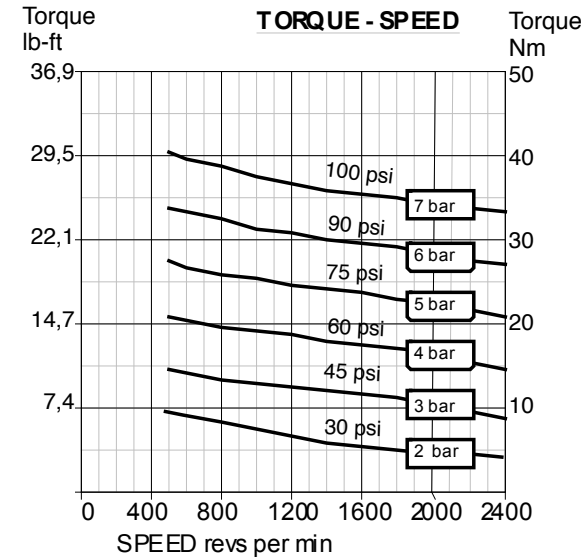

When designing for applications where the minimum starting torque requirement is equal to the running torque (as for example on hoists), the motor should be operated in the area below the minimum starting torque. This will ensure that the motor will always have adequate starting torque.

A pressure regulator should be used to control the air pressure to the motor, to limit the maximum output torque applied to the driven assembly.

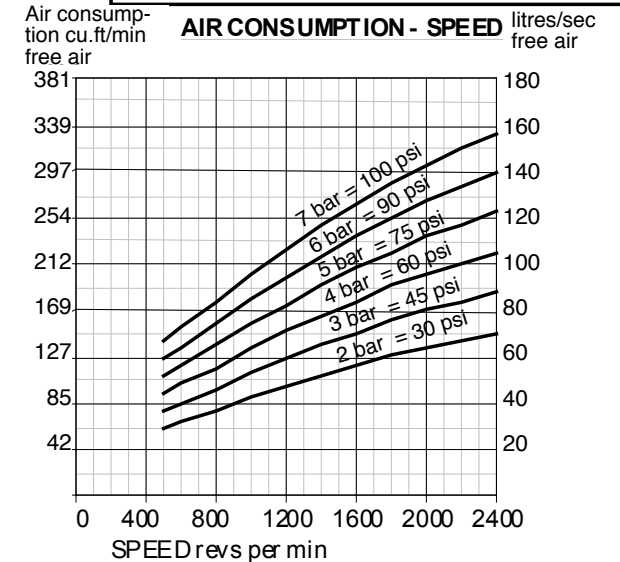
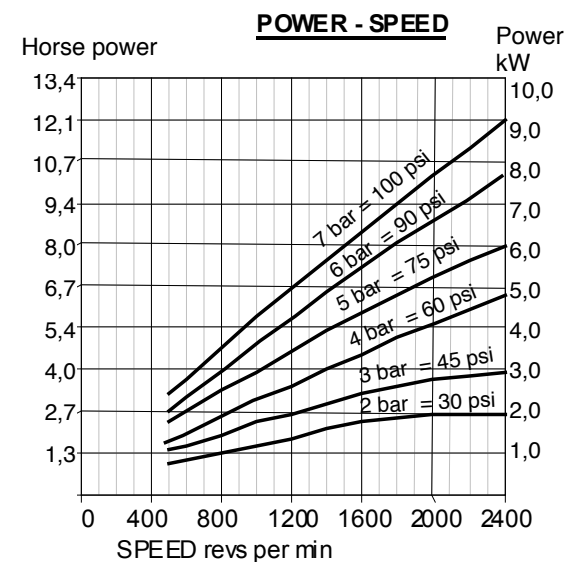

Muffler supplied with motor.

Motor is reversible.

ATTITUDE

The motor can be operated in all positions.

Maximum temperature -20°C to +80°C

(-4°F to +176°F).

Max. Overhung Force on motor shaft 1750N (400 lbf.)

Axial loads should be kept to a minimum.

AIRLINE FILTRATION AND LUBRICATION

Use 64 micron filtration or better. Choose a lubricator suitable for the flow required. Prior to initial start-up, inject oil into the inlet port.

Lubricator drop rate 8-10 drops/minute continuous operation

Lubricator drop rate 14-16 drops/minute intermittent operation

MAXIMUM CONTINUOUS SPEED 2400 RPM



COMPACT VANE AIR MOTORS

ADVANTAGES

GLOBE-ARCHIMEDES compact vane air motors are motors with incorporated reduction units. They offer a unique form of drive with advantages including:

- Simple and inexpensive variable speed and torque control with a flow control valve and/or pressure regulator.
- Intrinsically safe for explosion proof environments. All GLOBE-ARCHIMEDES compact vane air motors are certified according to the European Explosion Directive ATEX II cat. 2 G&D T5.
- Stalling under load. Air motors will not overheat or burn out.
- Instantly reversible, operated with a simple control valve.
- Control over a wide speed range.
- Resistant to warm, dirty and damp conditions.
- Cool running caused by the expanding air.
- High reliability thanks to the low number of moving parts.
- Compact and light weight compared to equivalent electric motors.
- No shock start up which improves the life span of your equipment.
- Available in stainless steel

WHY CHOOSE A GLOBE-ARCHIMEDES COMPACT VANE AIR MOTOR

- Stainless steel models available for use in aggressive environments and foodstuffs industry.
- Mounting via flange, threads on the front or on the motor housing.
- High torques and low speeds of rotation possible in application with limited mounting space.
- Small size for hand held machinery.
- Motors can be supplied directly coupled to a wide range of gearboxes for higher torques.

AIR SUPPLY

AIR QUALITY

To insure optimal working conditions for the GLOBE ARCHIMEDES compact vane air motors, the air supply must be dry, filtered and lubricated. A 5 micron filter is recommended. The air motors should be lubricated sufficiently.

AIR LINE RESTRICTIONS

Air line restrictions on the inlet side of the motor will result in performance loss. Therefore it is important to make sure that the desired air pressure is available at the motor during operation. The pressure reading at the compressor or pressure regulator may be different than the pressure available at the motor.

Performance loss can also occur by an exhaust restriction generating back pressure on the outlet side of the motor. An insufficiently sized silencer, valve or coupling is usually the cause.



ORDERING CODES

Motor type	Starting Torque
01	0,27 kW / 0,36 hp 0,4 NM / 0,3 lb-ft
02	0,27 kW / 0,36 hp 2 NM / 1,5 lb-ft
12	0,27 kW / 0,36 hp 12 NM / 8,8 lb-ft
02R	0,24 kW / 0,32 hp 2 NM / 1,5 lb-ft
05R	0,24 kW / 0,32 hp 5 NM / 3,7 lb-ft
10R	0,24 kW / 0,32 hp 10 NM / 7,4 lb-ft

* R = Reversible

Motor type	Starting Torque
01	0,67 kW / 0,90 hp 1,5 NM / 1,1 lb-ft
43	0,67 kW / 0,90 hp 43 NM / 31,7 lb-ft
05R	0,61 kW / 0,82 hp 5 NM / 3,7 lb-ft
34R	0,61 kW / 0,82 hp 34 NM / 25,1 lb-ft

* R = Reversible

Motor type	Starting Torque
70R	1,0 kW / 1,34 hp 70 NM / 51,6 lb-ft

*R = Reversible

Motor type
Stainless steel

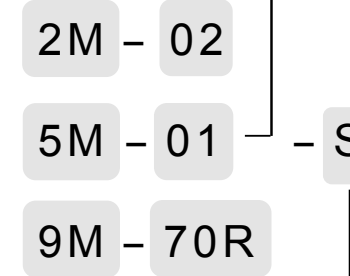

Use the ordering codes to create the GLOBE Archimedes Vane Air motor you want.

For example: 5M43 or 2M05RS.

DIMENSIONS 2M

Type	a	b	c	l	l1	l2	M	d	d1	d2	d3
2M01	52 (2.05")	64 (2.52")	5 (0.20")	160 (6.30")	20 (0.79")	25 (0.98")	M4	40h9 (1.57")	10h6 (0.39")	36h9 (1.42")	6.5 (0.26")
2M02				160 (6.30")							
2M12				190 (7.48")							
2M02R				160 (6.30")							
2M05R				190 (7.48")							
2M10R				190 (7.48")							

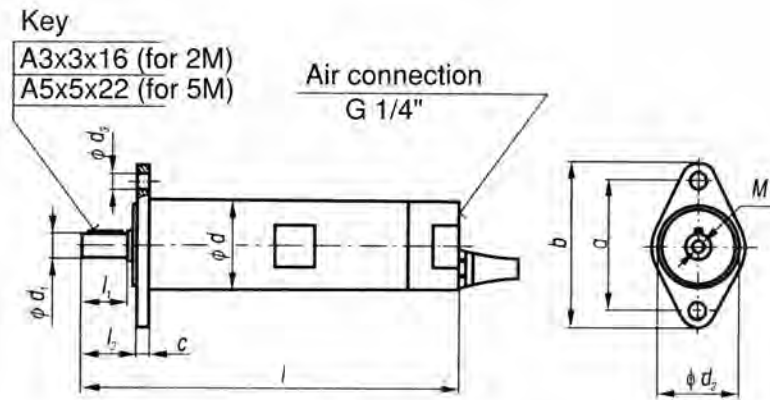

PERFORMANCES 2M

TYPE	POWER KW (HP)	MAX FREE SPEED	NOMINAL SPEED RPM	NOMINAL TORQUE NM (lb-ft)	MIN STARTING TORQUE Nm (lb-ft)	ROTATION	AIR CONSUMPTION (M3/min)	GEAR RATIO	WEIGHT Kg (lb)	
2M01	0.27 (0.36)	19.000	11.000	0,18 (0,13)	0.4 (0.29)	Counter Clockwise	0,5	1	0.9 (1.9)	
2M02		3700	2200	0,9 (0,66)	2 (1.47)			5	0.9 (1.9)	
2M12		710	450	4,5 (3,31)	12 (8.84)			25	1.1 (2.4)	
2M02R	0.24 (0.32)	3100	2000	0,8 (0,58)	2 (1.47)	Reversible		0,6	5	0.9 (1.9)
2M05R		1600	800	2,6 (1,91)	5 (3.69)				12	1.1 (2.4)
2M10R		600	400	4 (2,94)	10 (7.37)				25	1.1 (2.4)

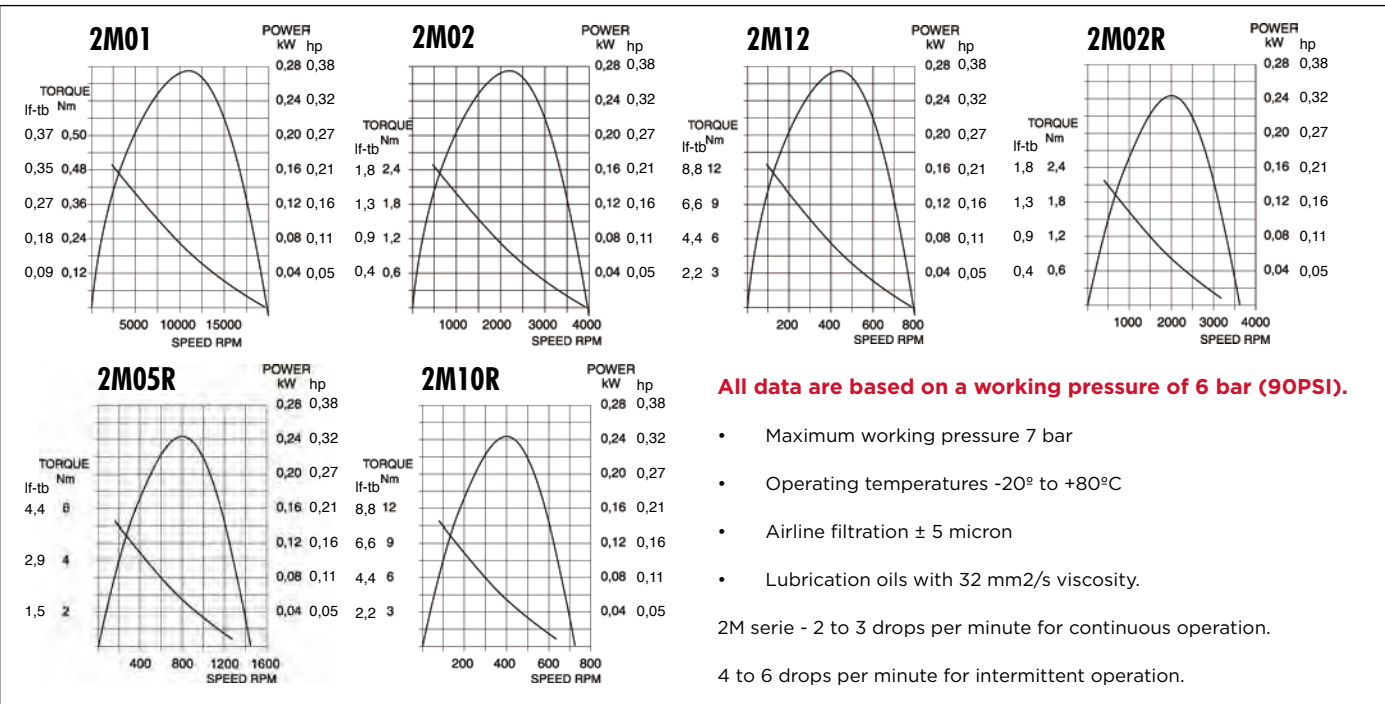

DIMENSIONS 5M

Type	a	b	c	l	l1	l2	M	d	d1	d2	d3
5M01	75 (2.95")	95 (3.74")	6 (0.24")	185 (7.28")	30 (1.18")	35 (1.38")	M6	55h9 (2.17")	14h6 (0.55)	52h9 (2.05")	11 (0.43")
5M43				230 (9.06")							
5M05R				185 (7.28")							
5M34R				230 (9.06")							

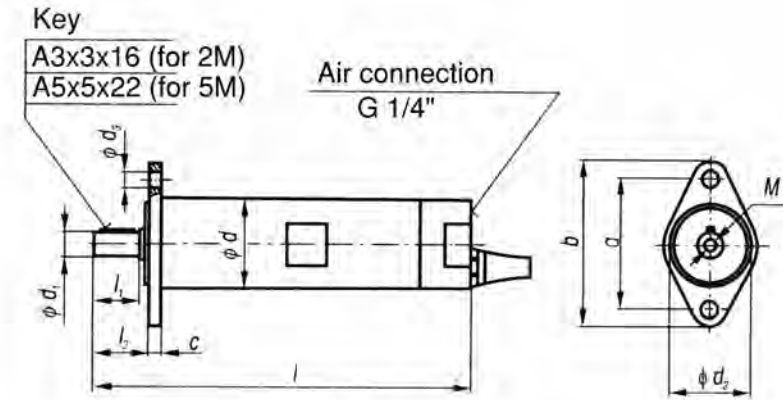

PERFORMANCES 5M

TYPE	POWER KW (HP)	MAX FREE SPEED	NOMINAL SPEED RPM	NOMINAL TORQUE NM (lb-ft)	MIN STARTING TORQUE Nm (lb-ft)	ROTATION	AIR CONSUMPTION (M3/min)	GEAR RATIO	WEIGHT Kg (lb)	
5M01	0.67 (0.90)	14.000	7000	0,9 (0,66)	1.5 (1.1)	Counter Clockwise	0,8	1	2.0 (4.4)	
5M43		450	250	27 (19,89)	43 (31.7)			36	2.4 (5.3)	
5M05R	0.61 (0.82)	3000	1750	3 (2,21)	5 (3.7)	Reversible		0,83	5	2.0 (4.4)
5M34R		420	250	20,5 (15,10)	34 (25.1)				36	2.4 (5.3)

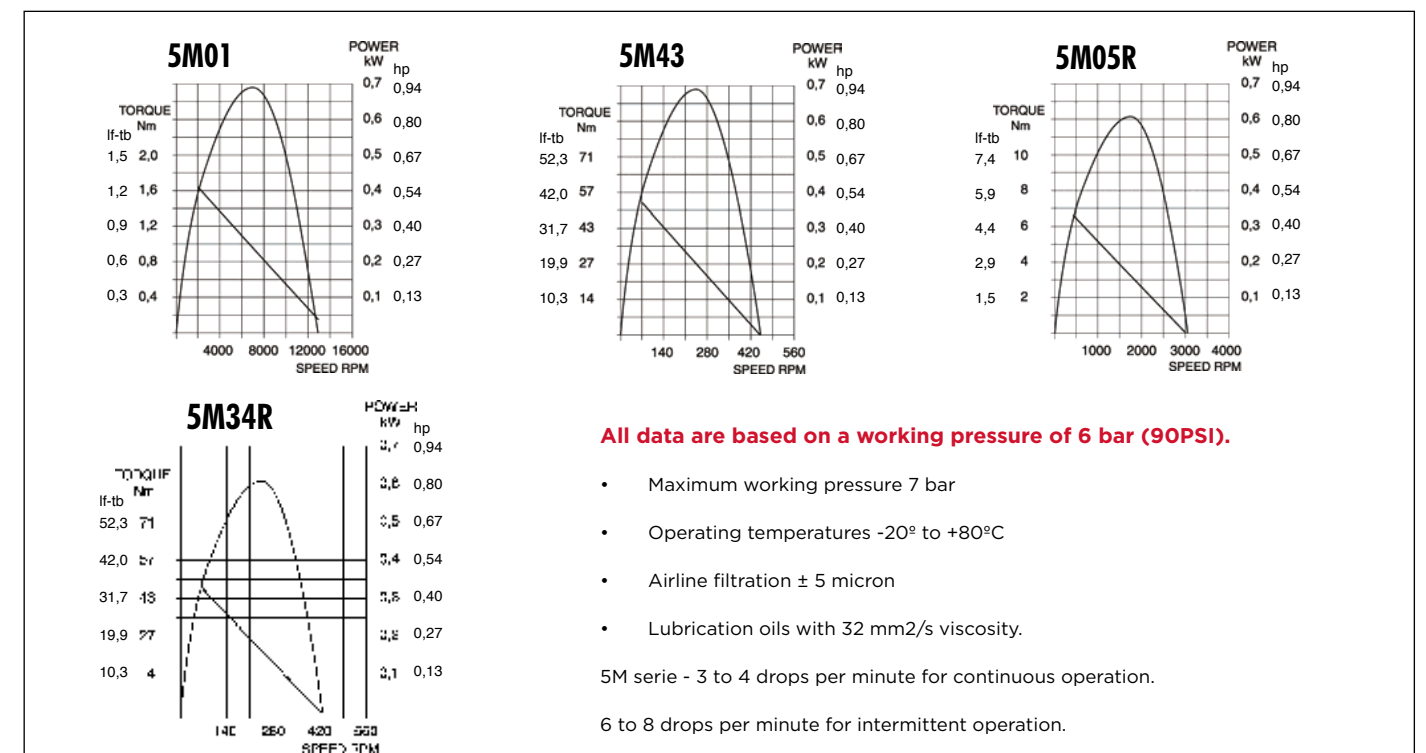

DIMENSIONS 9M

Type	a	b	c	l	l1	l2	l3	M	d	d1	d2	d3	d4
9M70R	75 (2.95")	95 (3.74")	6 (0.24")	270 (10.63")	30 (1.18")	35 (1.38")	110 (4.33")	M4	55h9 (2.17")	16h9 (0.63")	52h9 (2.05")	11 (0.43")	62 (2.44")

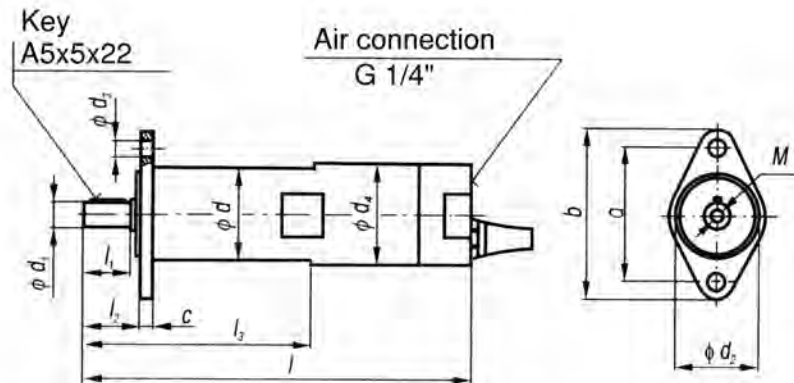

PERFORMANCES 9M

TYPE	POWER KW (HP)	MAX FREE SPEE	NOMINAL SPEED RPM	NOMINAL TORQUE NM (lb-ft)	MIN STARTING TORQUE Nm (lb-ft)	ROTATION	AIR CONSUMPTION (M3/min)	GEAR RATIO	WEIGHT Kg (lb)
9M70R	1.0 (1.34)	440	220	40 (29,48)	70 (51.6)	Reversible	1.36	36	3.3 (7.26)

9M70R

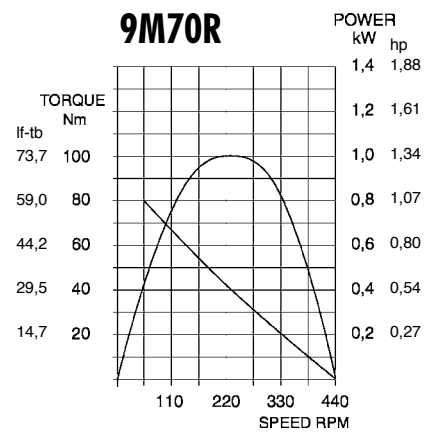

All data are based on a working pressure of 6 bar (90PSI).

- Maximum working pressure 7 bar
 - Operating temperatures -20° to +80°C
 - Airline filtration \pm 5 micron
 - Lubrication oils with 32 mm²/s viscosity.
- 2M serie - 2 to 3 drops per minute for continuous operation.
4 to 6 drops per minute for intermittent operation.

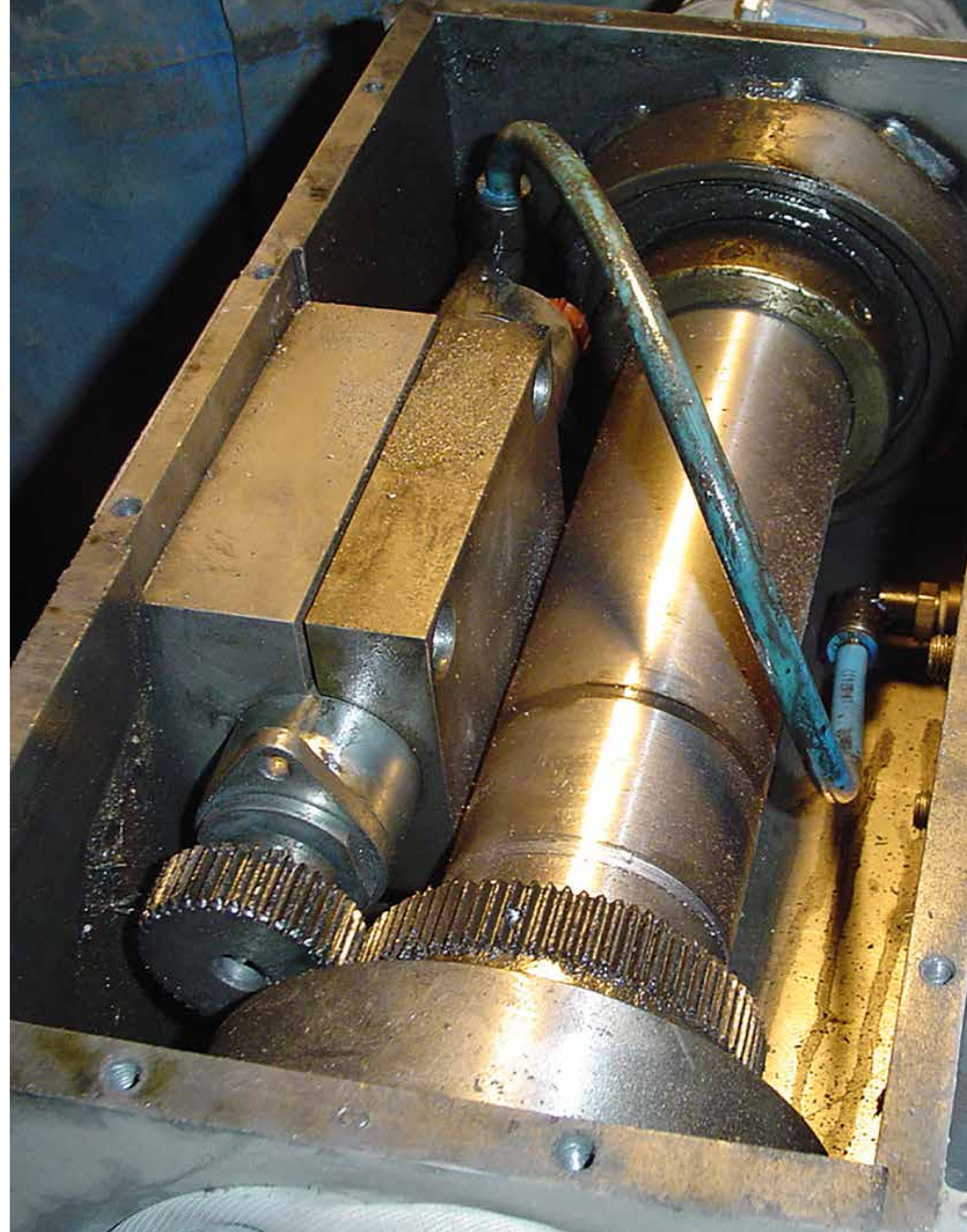

GLOBE COMPACT VANE MOTORS SERIES M53

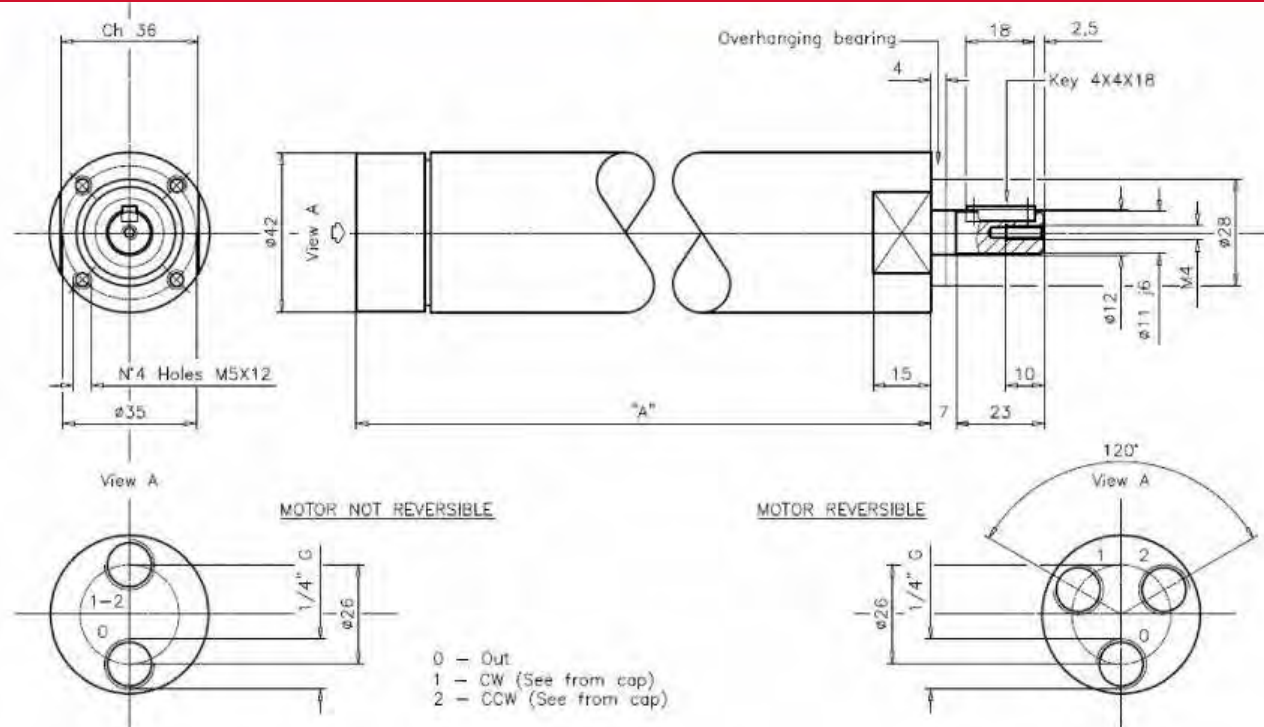

Model	Free speed r/min			Speed at max power r/min			Torque max. power Kgm			Starting torque NM			Torque NM			Quote "A" mm	Weight Kg.	N° Reduction gear	
	Reversible	Not Reversible		7 bar	5 bar	3 bar	7 bar	5 bar	3 bar	7 bar	5 bar	3 bar	7 bar	5 bar	3 bar				7 bar
M53R0	M53N0	15000	13400	11800	7500	6700	5900	0,5	0,3	0,1	0,6	0,4	0,2	0,9	0,6	0,3	118	0,9	0
M53R1A	M53N1A	3800	3400	3000	1900	1700	1500	1,9	1,4	0,7	2,9	1,8	1,0	3,9	2,8	1,4	118	0,9	1
M53R1B	M53N1B	2800	2550	2250	1400	1275	1125	2,6	1,9	0,9	3,9	2,8	1,3	5,2	3,8	1,8	118	0,9	1
M53R1C	M53N1C	2400	2180	1930	1200	1090	965	3,0	2,2	1,1	4,5	3,3	1,6	6,0	4,4	2,2	118	0,9	1
M53R1D	M53N1D	2100	1900	1690	1050	850	845	3,5	2,4	1,2	5,2	4,2	1,8	7,0	5,6	2,4	118	0,9	1
M53R2	M53N2	1200	1000	900	600	500	450	6,3	4,8	2,3	9,6	6,0	3,3	13	9,3	4,7	135	1,0	2
M53R2A	M53N2A	900	755	670	450	377	335	8,0	6,3	3,1	12	9,4	4,6	16	13	6,2	135	1,0	2
M53R2B	M53N2B	630	565	500	315	282	230	11	8,4	4,2	17	13	6,3	23	17	8,4	135	1,0	2
M53R2C	M53N2C	540	485	430	270	242	215	13	10	4,9	19	15	7,3	26	20	9,8	135	1,0	2
M53R2D	M53N2D	480	425	375	240	212	187	15	11	5,6	22	16	8,4	30	22	11	135	1,0	2
M53R3	M53N3	270	220	200	135	110	100	27	20	10	40	31	15	53	41	21	157	1,2	3
M53R3A	M53N3A	190	168	150	85	84	75	42	28	14	63	42	21	84	56	28	157	1,2	3
M53R3B	M53N3B	140	126	110	70	63	55	51	38	19	75	57	28	102	76	38	157	1,2	3
M53R3C	M53N3C	120	108	95	60	54	48	60	44	22	90	66	33	120	88	44	157	1,2	3
M53R3D	M53N3D	110	95	83	55	47	42	65	50	25	97	75	37	130	100	50	157	1,2	3
M53R4	M53N4	60	50	45	30	25	22	140	93	47	210	140	70	280	185	93	175	1,3	4
M53R4A	M53N4A	46	37	33	23	19	16	157	125	65	235	187	97	315	250	130	175	1,3	4
M53R4B	M53N4B	32	28	24	16	14	12	230	170	87	345	255	145	460	340	194	175	1,3	4
M53R4C	M53N4C	26	24	21	13	12	10	277	198	105	410	297	157	550	396	210	175	1,3	4
M53R4D	M53N4D	23	21	18	11	10	9	328	238	117	485	357	175	650	476	234	175	1,3	4

Air consum	a 6 bar 13,5 l/sec	a 5 bar 11,6 l/sec	a 4 bar 9,6 l/sec	a 3 bar 7,7 l/sec	a 2 bar 5,7 l/sec
------------	--------------------	--------------------	-------------------	-------------------	-------------------

ATTENTION

The M53 air motors cannot be used over 60Nm torque. The figures shown in the green colored area should be considered purely as an indication.

LUBRICATION:

2-3 gocce/1' continuous operation
4-6 gocce/1' intermittent operation

FILTRATION:

Use 64 micron filtration or better

RADIAL LOAD:

2000 N max.

AXIAL LOAD:

Not admitted

OPERATIVE TEMPERATURE:

da -20°C a +80°C

PNEUMATIC GLOBE COMPACT VANE MOTORS M53 SERIES | HP 0,53 KW 0,38

ATTITUDE:

The motors of the M53 series are standard with case and end plate in AISI 303 stainless steel, and the possibility, upon request, of also supplying the shaft in AISI 303 stainless steel by adding "051" after the M53 code.

necessary. To achieve this, all motors may be assembled with a protruding bearing. To order the motor with this modification, add "019" after the code.

The M53 offers reversible and uni directional motors. Non reversible motors are furnished with standard counterclockwise rotation (counter clockwise facing the shaft). Non reversible motors are delivered with a standard CCW rotation (counter clock wise) while looked upon shaft. To order them with a CW rotation (clock wise) add "015" after the code. There is often the need to mount the motor to other equipment or simply to an interfacing flange, in this case safe alignment is

The single-stage, two-stage and three-stage models may also be internally equipped with a brake device that prevents the exit shaft to rotate when the motor is in static condition. To order the motor with this devise, add "102" after the code.

The entire line is in accordance to European Directive for products destined to be uses in potentially explosive atmospheres ATEX II cat.2 G&D T3.

All the models of the M53 series can be ordered in a no lube version by putting 'N' in front of the article code.

STAINLESS STEEL COMPACT VANE AIR MOTORS

Each type of the GLOBE-Archimedes compact vane air motors are also available in stainless steel models. The

stainless steel models have the same performances and dimensions as the standard versions.





RADIAL PISTON (RM) AIR MOTORS

The GLOBE RM air motors are a series of heavy duty radial piston air motors offering an exceptional range of control valve and output options. The motors are four or five cylinder radial piston design with oil bath lubrication and are designed to develop greater power than other motors of equivalent size.

RM motors are most suitable for heavy duty applications and can be supplied direct coupled to gearboxes.

A variety of operating conditions can be achieved by utilisation of pressure regulators and flow control valves.

Natural gas and other gases can also be used. Please consult our Applications Department.

ADVANTAGES INCLUDE:

- Modular motor, brake, gearbox and control valve options
- Relatively inexpensive variable speed control
- Intrinsically safe in hazardous environments (e.g. mines, petro-chemical etc.)
- Instantly reversible
- Resistant to dirty, damp conditions
- Positive start
- Rugged design
- Variety of mountings
- NEMA and S.A.E. interfaces:
RM210, RM310, RM410, RM510, and RM610 motors can be supplied in configurations approximating to NEMA interfaces.
RM410, RM510 and RM610 are also available with S.A.E. pump drives.

Type motor	
110	1,7 kW / 2,3 hp
210	4 kW / 5,4 hp
310	7,5 kW / 10,1 hp
410	14 kW / 18,8 hp
510	22 kW / 29,5 hp
610	23 kW / 30,8 hp

Direction of control valve	
-	Equal power
CW	Clockwise
CCW	Counter Clockwise

RM - 210 RCV CW Brake

Type of control valve	
RCV	Remote control valve
HCV	Hand control valve



GRAPH 1 TORQUE - SPEED

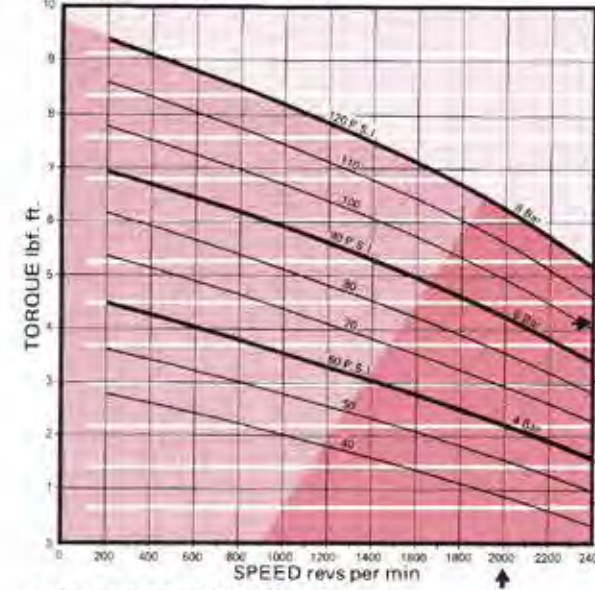

GRAPH 2 STARTING TORQUE - PRESSURE

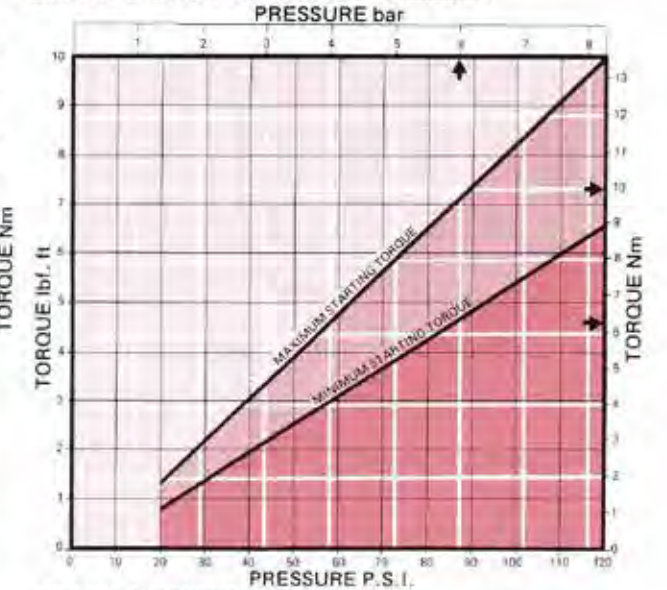

GRAPH 3 POWER - SPEED

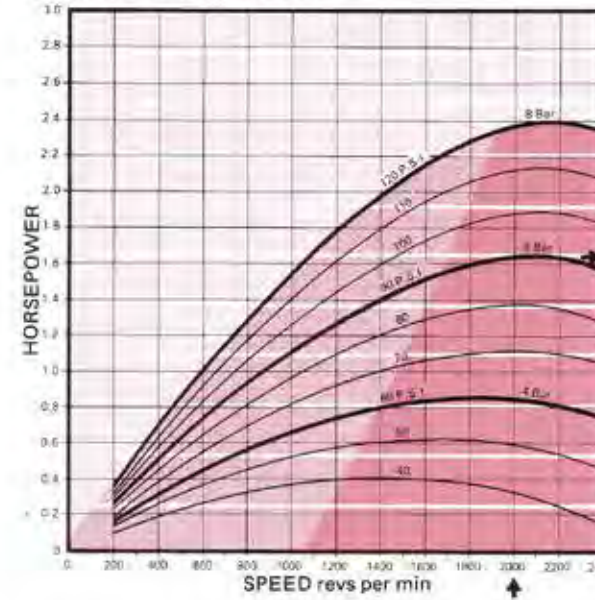

GRAPH 4 CONSUMPTION - SPEED

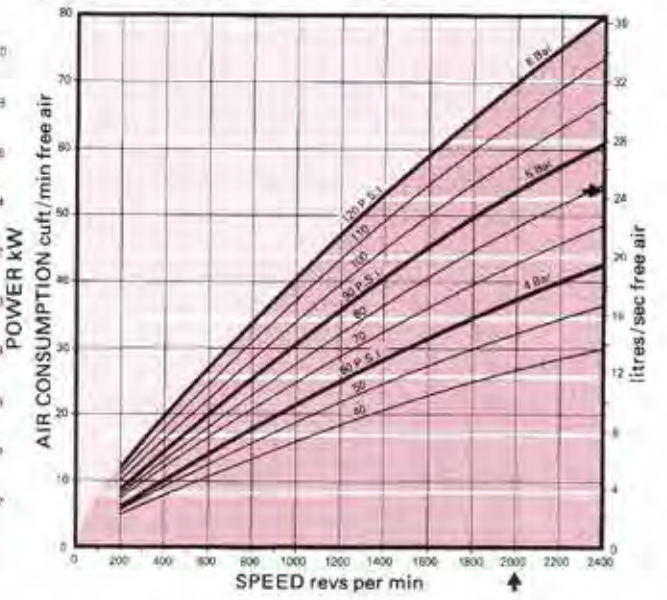

Reading graphs - Scales have been adjusted to enable bar and p.s.i. to be read from a common curve. Therefore only read p.s.i. with the left hand axis and bar with the right hand axis.

MOTOR SELECTION

Motor performance can be derived from the above graphs as in the examples shown. Where motors are not required to start under load, such as fan drives, selection may be made using either Graph 1 or Graph 3 using the required running torque or power only. For applications where the motor starts under load, such as hoists, winches or track drives, the starting torque in Graph 2

must also be considered. Starting torque varies between the maximum and minimum values shown, depending on the angular position of the output shaft.

1. Running torque example RM110 at 6 bar gives 5,5 Nm torque at 2000 r.p.m.
2. Starting torque example: RM110 at 6 bar gives between 6,2 and 10 Nm at start depending on output shaft position.
3. Output power example: RM110 at 6 bar gives 1,19 kW at 2000 r.p.m.
4. Air consumption exaple: RM110 at 6 bar and 2000 r.p.m. requires 24,2 l/sec. free air.

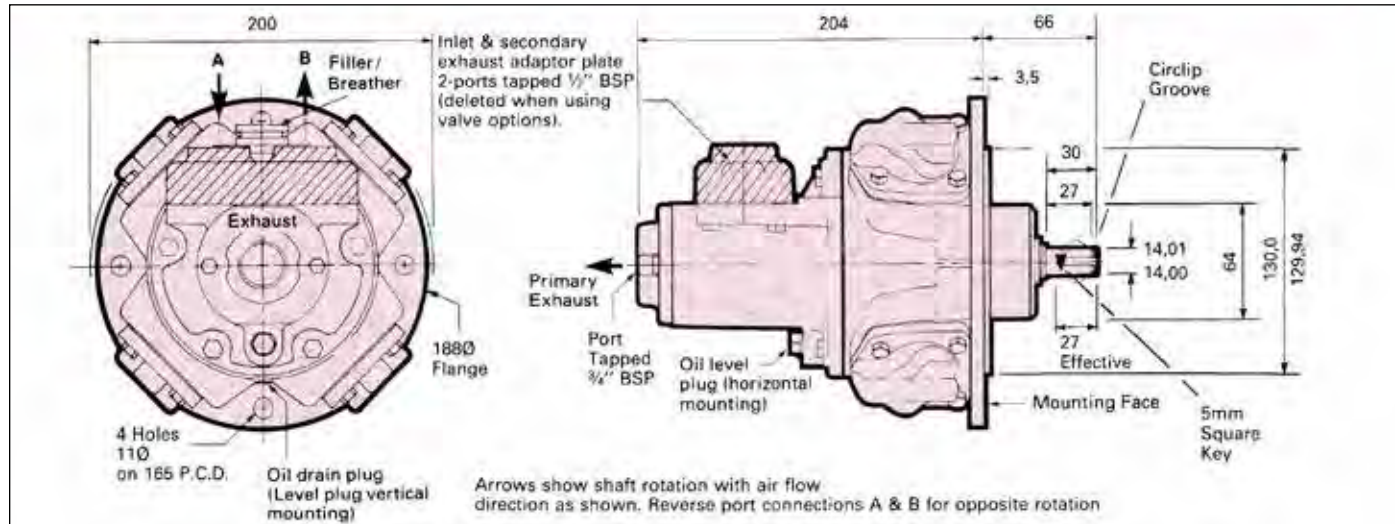

Reading graphs - Scales have been adjusted to enable bar and p.s.i. to be read from a common curve. Therefore only read p.s.i. with the left hand axis and bar with the right hand axis.

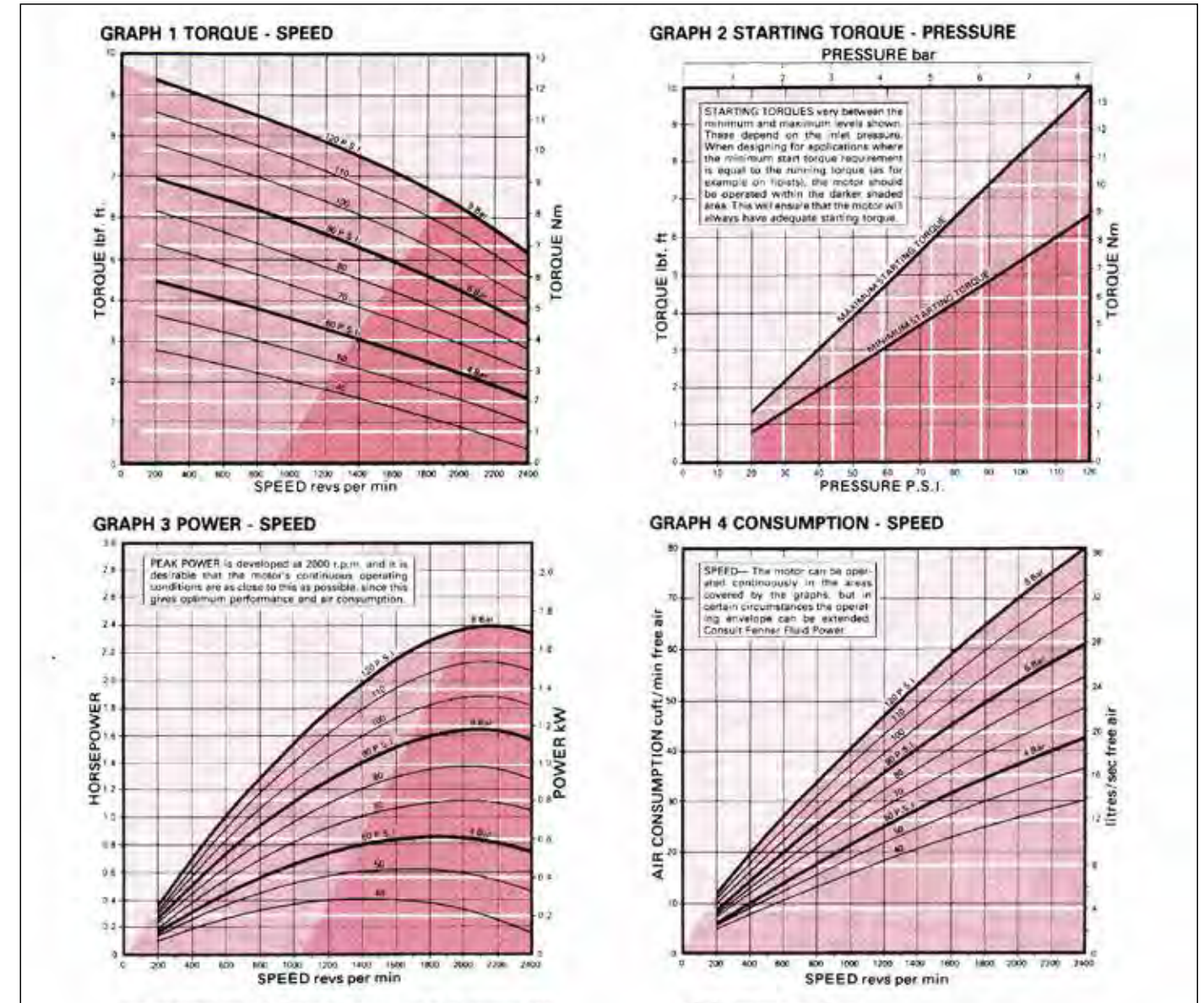

LUBRICATING OIL CAPACITIES

Horizontal 75 ml. Vertical 150ml.
Use a good quality hydraulic oil with a viscosity of around 100cSt (460SSU) at 40°C.

AIRLINE FILTRATION AND LUBRICATION

Use 64 micron filtration or better. Choose a lubricator suitable for the flow required. Prior to initial start-up, inject oil into the inlet port.

Lubricator drop rate: 3-4 drops / minute continuous operation.

Lubricator drop rate: 6-10 drops / minute intermittent operation.

MASS (MOTOR ONLY)

13 kg

MOMENT OF INERTIA

of rotating parts 0,01 gm²

MAX OVERHUNG FORCE SHAFT

445 N.

TEMPERATURE RANGE

-20°C to +80°C

RM110 GEARED MOTOR INSTALLATION DETAILS

Maximum performance details listed below at 6 bar (90 psi). The performance under different conditions can be obtained by using the curves on page 150. A typical minimum gearbox efficiency of 90% can be expected. For higher pressures consult the manufacturer or their

distributors. The maximum overhung force is assumed acting midmay along the output shaft; for other positions or higher loads on intermittent applications; consult the manufacturer of their distributors.

PERFORMANCE SUMMARY

Gearbox Ratio	Maximum Power Conditions					Approx. Min. Start Torque		Max. Cont.	Max. Overhung Force	
	Kw	hp	rpm	Torque		Nm	lbf. ft.	rpm	N	lbf.
				Nm	lbf. ft.					
2,8	1,1	1,5	758	14	10	17	13	866	970	218
5,1	1,1	1,5	415	25	19	30	23	474	1050	236
7,6	1,1	1,5	278	37	28	45	35	317	1110	250
9,1	1,1	1,5	231	45	34	54	42	264	1210	272
14	1,1	1,5	156	67	51	81	62	178	1320	297
22	1,1	1,5	94	110	84	133	102	108	2025	456
30	1,1	1,5	69	149	114	181	138	79	2180	491
60	1,1	1,4	35	280	213	339	259	40	4540	1020
88	1,1	1,4	24	414	316	501	382	27	4810	1080

BASE MOUNTED GEARBOX

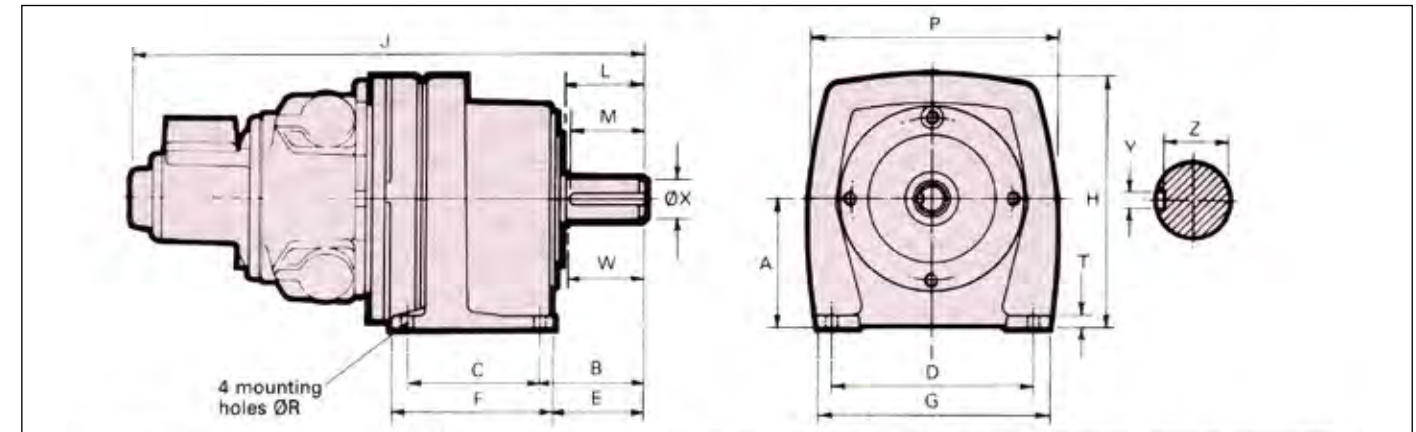

RATIO	A	B	C	D	E	F	G	H	J	L	M	P	R	T	W	X	Y	Z	MASS
2,8 to 14:1	100	80	105	140	65	135	170	195	405	53	45	188	11	13	50	24,009	7,964	20,0	23,6 kg
																23,996	8,000	19,8	
22:1	125	90	125	170	75	155	200	240	421	62	55	200	14	15	60	28,009	7,964	24,0	29,5 kg
																27,996	8,000	23,8	
30:1	112	63	115	170	50,5	140	195	212	473	51	45	202	9	13	50	24,009	7,964	20,0	39 kg
																23,996	8,000	19,8	
60 & 88:1	132	83	135	205	68	165	235	257	505	63	55	252	12	14	60	28,009	7,964	24,0	65 kg
																27,996	8,000	23,8	

FLANGE MOUNTED GEARBOX

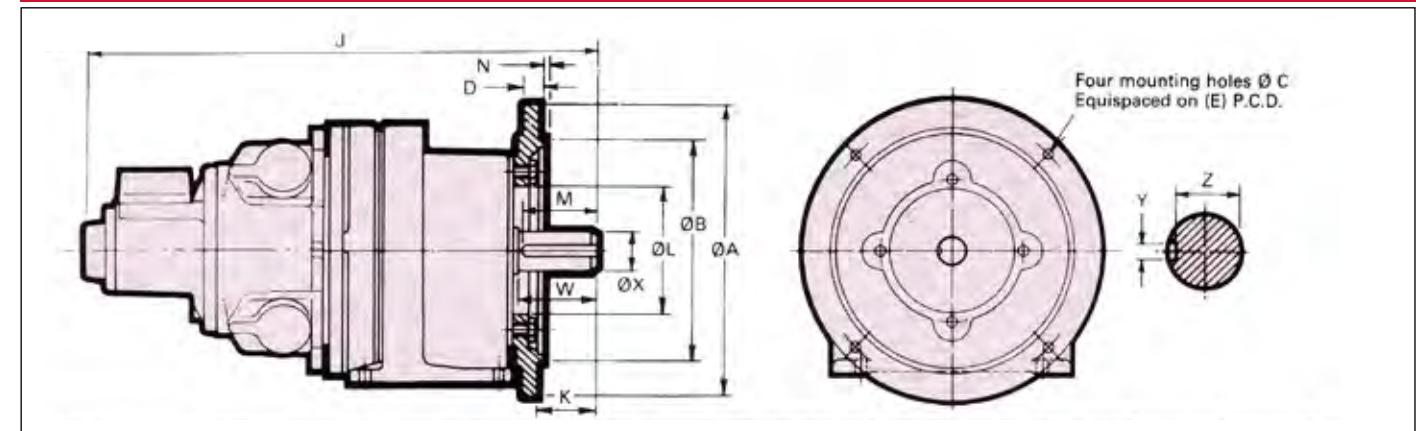

RATIO	A	B	C	D	E	J	K	L	M	N	W	X	Y	Z	MASS
2,8 to 14:1	200	130,000	12	11	165	405	50	N.A.	45	3,5	50	24,009	7,964	20,0	23,6 kg
		129,937										23,996	8,000	19,8	
22:1	250	180,000	15	11	215	421	60	N.A.	55	4,0	60	28,009	7,964	24,0	29,5 kg
		179,937										27,996	8,000	23,8	
30:1	250	180,000	14	12	215	473	34,5	70	45	3,0	50	24,009	7,964	20,0	42 kg
		179,937										23,996	8,000	19,8	
60 & 88:1	300	230,000	14	16	265	505	41	130	55	5,0	60	28,009	7,964	24,0	69 kg
		229,928										27,996	8,000	23,8	

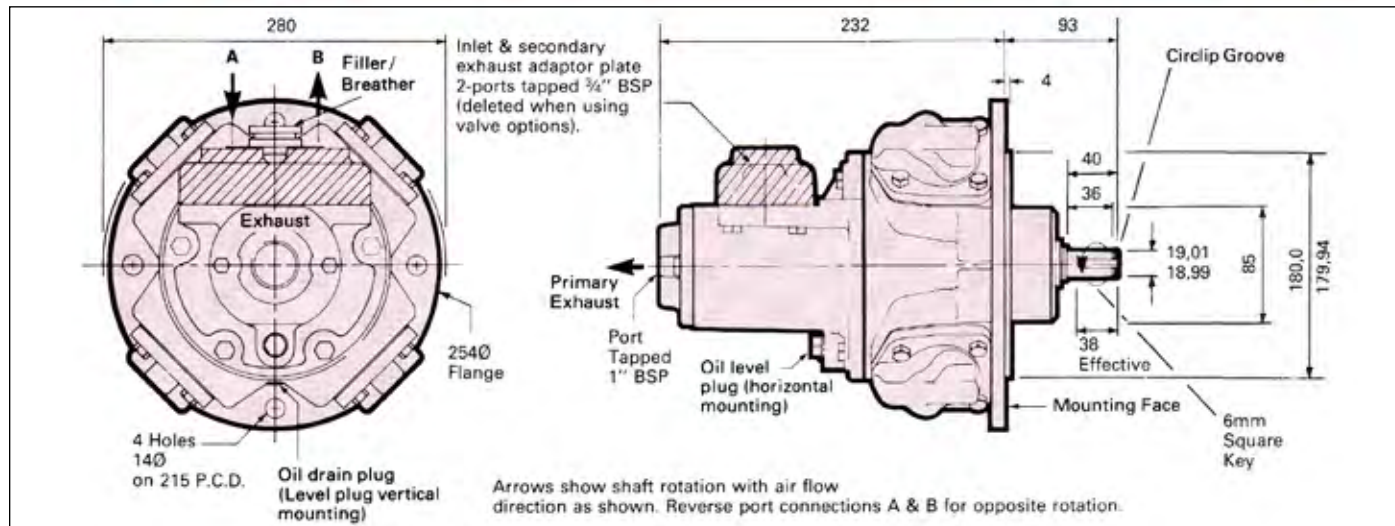

Reading graphs - Scales have been adjusted to enable bar and p.s.i. to be read from a common curve. Therefore only read p.s.i. with the left hand axis and bar with the right hand axis.

GRAPH 1 TORQUE - SPEED

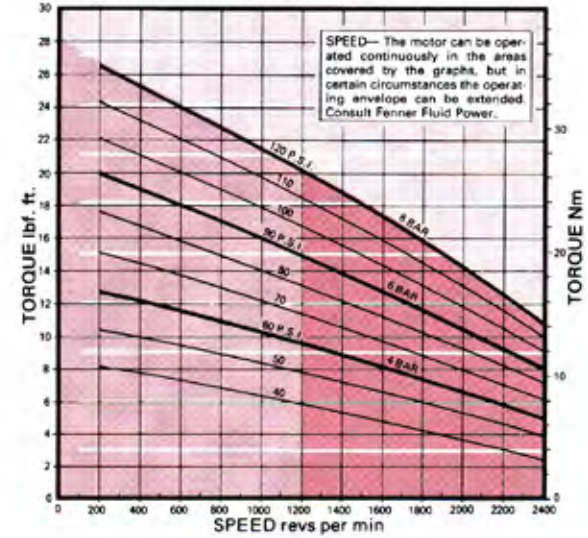

GRAPH 2 STARTING TORQUE - PRESSURE

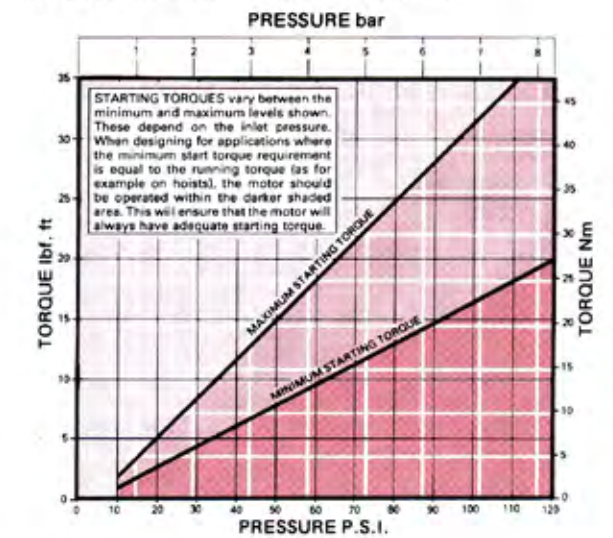

GRAPH 3 POWER - SPEED

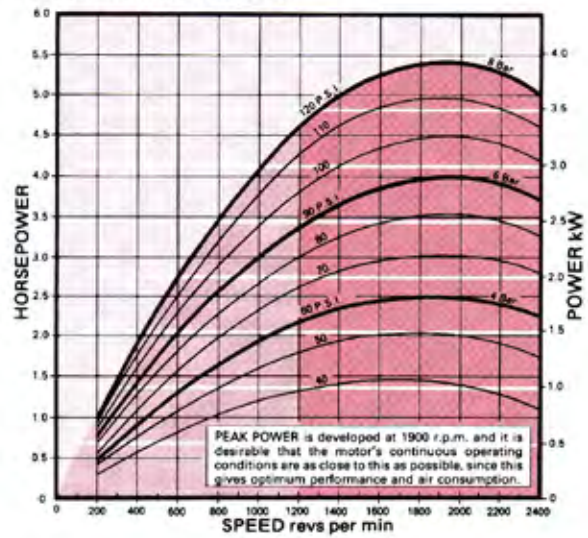

GRAPH 4 CONSUMPTION - SPEED

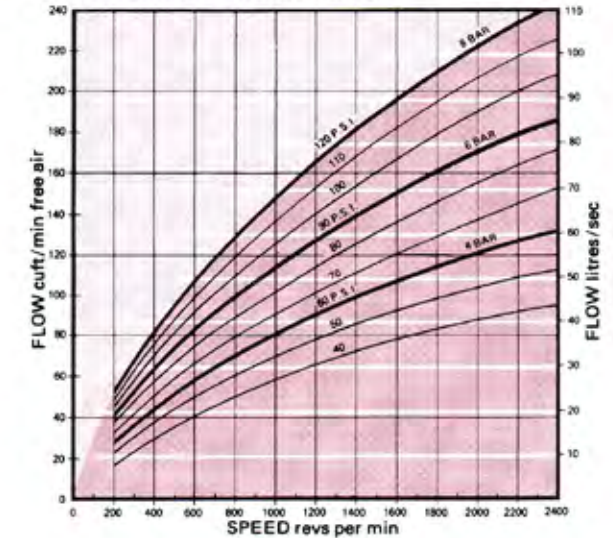

LUBRICATING OIL CAPACITIES

Horizontal 330 ml. Vertical 450ml.

Use a good quality hydraulic oil with a viscosity of around 100cSt (460SSU) at 40°C.

AIRLINE FILTRATION AND LUBRICATION

Use 64 micron filtration or better. Choose a lubricator suitable for the flow required. Prior to initial start-up, inject oil into the inlet port.

Lubricator drop rate: 3-4 drops / minute continuous operation.

Lubricator drop rate: 6-10 drops / minute intermittent operation.

MASS (MOTOR ONLY)

26 kg

MOMENT OF INERTIA

of rotating parts 0,56 gm²

MAX OVERHUNG FORCE SHAFT

890 N.

TEMPERATURE RANGE

-20°C to +80°C

RM210 GEARED MOTOR INSTALLATION DETAILS

Maximum performance details listed below at 6 bar (90 psi). The performance under different conditions can be obtained by using the curves on page 154. A typical minimum gearbox efficiency of 90% can be expected. For higher pressures consult the manufacturer or their

distributors. The maximum overhung force is assumed acting midway along the output shaft; for other positions or higher loads on intermittent applications; consult the manufacturer of their distributors.

PERFORMANCE SUMMARY

Gearbox Ratio	Maximum Power Conditions					Approx. Min. Start Torque		Max. Cont.	Max. Overhung Force	
	Kw	hp	rpm	Torque		Nm	lbf. ft.	rpm	N	lbf.
				Nm	lbf. ft.					
2,7	2,8	3,8	720	36	27	49	37	886	1200	270
4,9	2,8	3,8	401	65	49	88	67	494	1470	331
7,6	2,8	3,8	256	101	77	137	105	315	1650	371
9,1	2,8	3,8	214	121	93	165	126	263	1760	396
13	2,8	3,8	146	178	136	242	184	179	1850	416
22	2,8	3,8	87	297	226	403	307	108	6140	1382
32	2,7	3,6	62	399	304	541	413	76	6590	1480
58	2,7	3,6	34	730	557	991	756	41	11100	2490
78	2,7	3,6	25	989	754	1342	1023	31	11100	2490

BASE MOUNTED GEARBOX

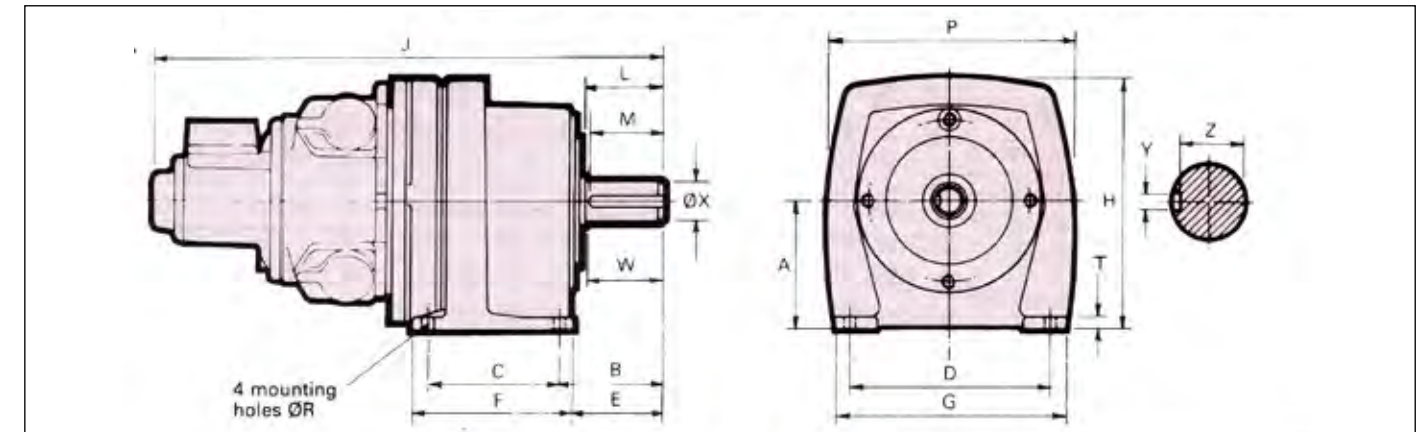

RATIO	A	B	C	D	E	F	G	H	J	L	M	P	R	T	W	X	Y	Z	MASS
2,7 to 13:1	125	90	125	170	75	155	200	252	476	62	55	254	14	15	50	28,009	7,964	24,0	50,6 kg
																27,996	8,000	23,8	
22 to 32:1	170	106	160	230	91	190	290	320	615	83	75	302	12	16	80	32,018	9,964	27,0	100 kg
																32,009	10,000	26,8	
58 & 78:1	170	118	170	240	94	218	290	320	648	83	75	302	14	18	80	38,018	9,964	33,0	106 kg
																38,002	10,000	32,8	

FLANGE MOUNTED GEARBOX

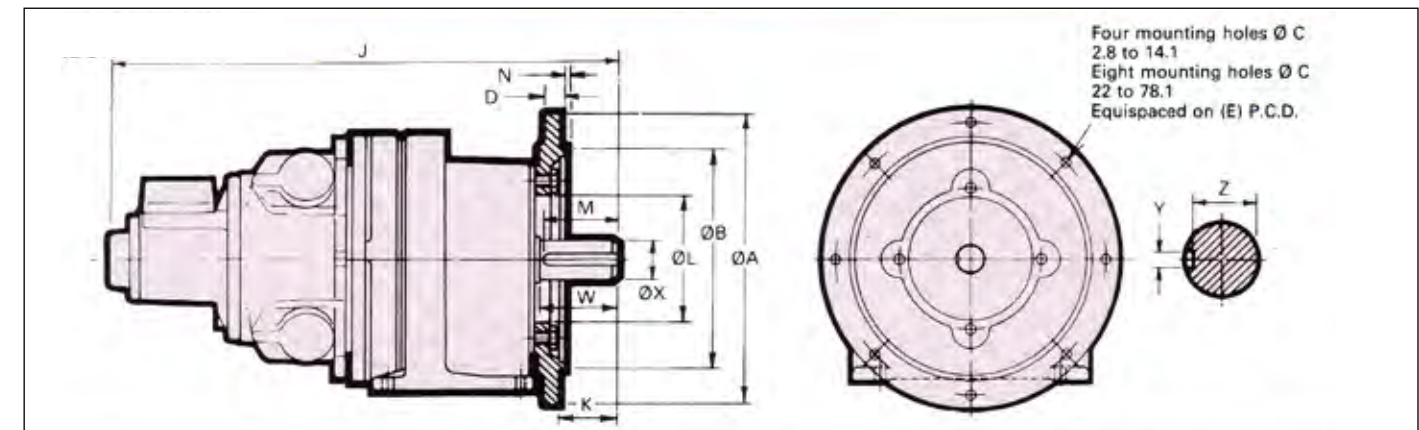

RATIO	A	B	C	D	E	J	K	L	M	N	W	X	Y	Z	MASS
2,7 to 13:1	250	180,000	15	11	215	476	60	N.A.	55	4	60	28,009	7,964	24,0	50,6 kg
		179,937										27,996	8,000	23,8	
22 & 32:1	350	250,000	18	18	300	615	59	130	75	5	80	32,018	9,964	27,0	112 kg
		249,928										32,009	10,000	26,8	
58 & 78:1	350	250,000	18	18	300	648	59	130	75	5	80	38,018	9,964	33,0	118 kg
		249,928										38,002	10,000	32,8	

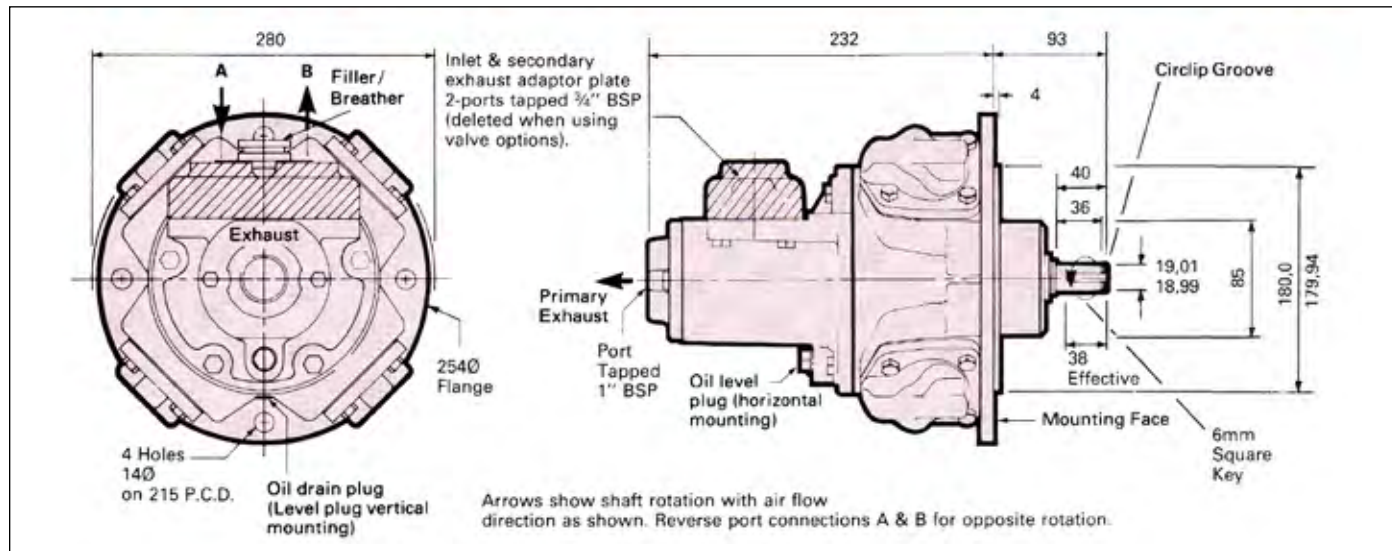

Reading graphs - Scales have been adjusted to enable bar and p.s.i. to be read from a common curve. Therefore only read p.s.i. with the left hand axis and bar with the right hand axis.

GRAPH 1 TORQUE - SPEED

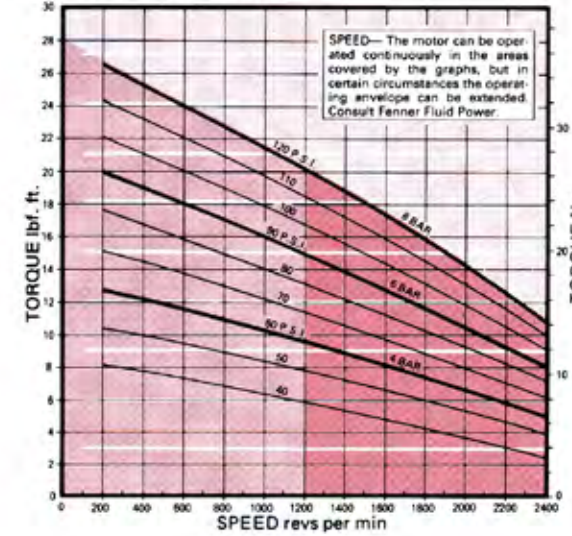

GRAPH 2 STARTING TORQUE - PRESSURE

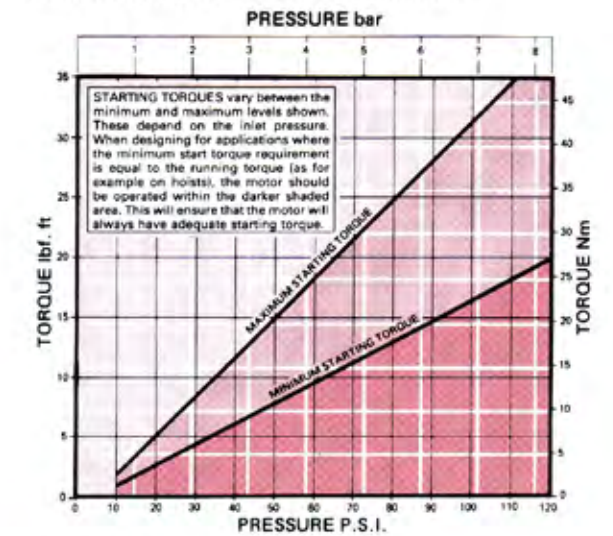

GRAPH 3 POWER - SPEED

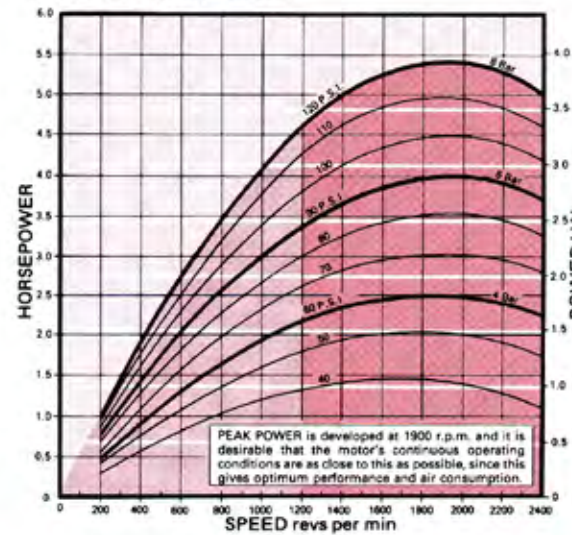

GRAPH 4 CONSUMPTION - SPEED

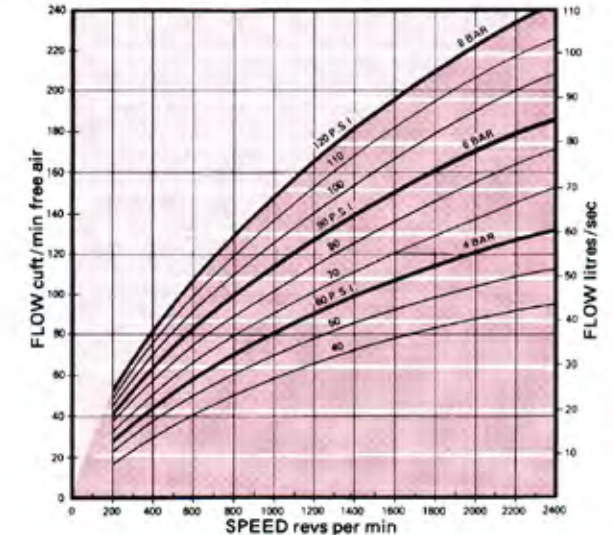

LUBRICATING OIL CAPACITIES

Horizontal 330 ml. Vertical 450ml.

Use a good quality hydraulic oil with a viscosity of around 100cSt (460SSU) at 40°C.

AIRLINE FILTRATION AND LUBRICATION

Use 64 micron filtration or better. Choose a lubricator suitable for the flow required. Prior to initial start-up, inject oil into the inlet port.

Lubricator drop rate: 3-4 drops / minute continuous operation.

Lubricator drop rate: 6-10 drops / minute intermittent operation.

MASS (MOTOR ONLY)

26 kg

MOMENT OF INERTIA

of rotating parts 0,56 gm²

MAX OVERHUNG FORCE SHAFT

890 N.

TEMPERATURE RANGE

-20°C to +80°C

RM310 GEARED MOTOR INSTALLATION DETAILS

Maximum performance details listed below at 6 bar (90 psi). The performance under different conditions can be obtained by using the curves on page 158. A typical minimum gearbox efficiency of 90% can be expected. For higher pressures consult the manufacturer or their

distributors. The maximum overhung force is assumed acting midway along the output shaft; for other positions or higher loads on intermittent applications; consult the manufacturer of their distributors.

PERFORMANCE SUMMARY

Gearbox Ratio	Maximum Power Conditions					Approx. Min. Start Torque		Max. Cont.	Max. Overhung Force	
	Kw	hp	rpm	Torque		Nm	lbf. ft.	rpm	N	lbf.
				Nm	lbf. ft.					
2,8	6,1	8,2	647	87	66	90	68	863	1270	286
5,0	6,1	8,2	358	158	120	162	124	477	1490	335
7,1	6,1	8,2	253	223	170	230	175	337	1690	380
8,9	6,1	8,2	203	278	212	287	219	270	1770	398
13	6,1	8,2	136	414	316	427	325	182	1860	419
21	5,8	7,8	86	624	476	643	490	114	8010	1800
31	5,8	7,8	57	931	710	959	732	77	10200	2290
56	5,8	7,8	32	1674	1277	1725	1316	43	12900	2900
85	5,8	7,8	21	2512	1916	2588	1974	28	21400	4810

BASE MOUNTED GEARBOX

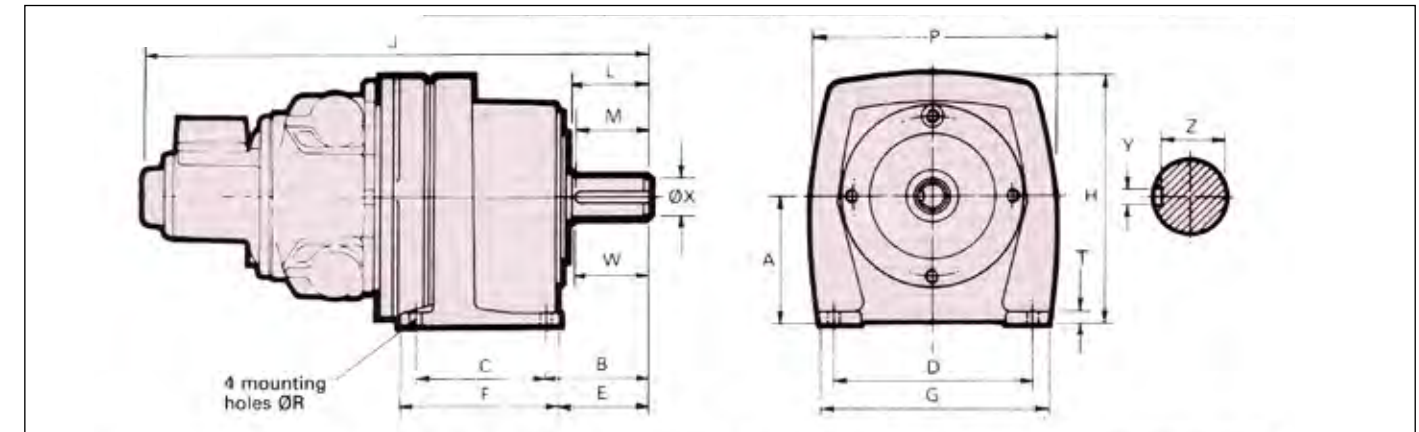

RATIO	A	B	C	D	E	F	G	H	J	L	M	P	R	T	W	X	Y	Z	MASS
2,8 to 13:1	155	115	165	210	95	205	250	308	600	83	75	305	14	25	80	38,018	9,964	33,0	85,5 kg
																38,002	10,000	32,8	
21 & 31:1	170	118	170	240	94	218	290	320	702	83	75	305	14	18	80	38,018	9,964	33,0	130 kg
																38,002	10,000	32,8	
56:1	190	150	195	275	123	247	320	365	710	114	100	350	22	22	114	45,018	13,957	39,5	145 kg
																45,002	14,000	39,3	
85:1	225	155	265	335	133	312	390	425	778	124	120	400	22	25	124	55,030	15,597	49,0	200 kg
																55,011	16,000	49,8	

FLANGE MOUNTED GEARBOX

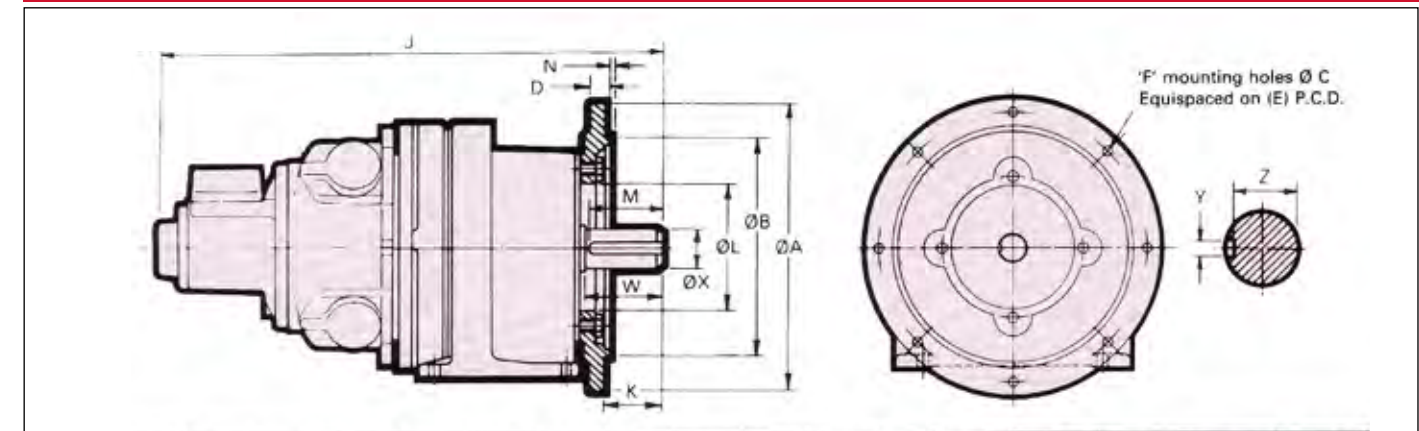

RATIO	A	B	C	D	E	F	J	K	L	M	N	W	X	Y	Z	MASS
2,8 to 13:1	300	230,000	15	15	265	4	600	80	N.A.	75	4	80	38,018	9,964	33,0	85,5 kg
		229,928											38,002	10,000	32,8	
21 & 31:1	350	250,000	18	18	300	4	702	59	130	75	5	80	38,018	9,964	33,0	138 kg
		249,928											38,002	10,000	32,8	
56:1	450	350,000	19	20	400	8	710	80	180	100	5	114	45,018	13,957	39,5	155 kg
		349,911											45,002	14,000	39,3	
85:1	550	450,000	19	22	500	8	778	85	230	120	5	124	55,030	15,597	49,0	212 kg
		449,903											55,011	16,000	48,8	

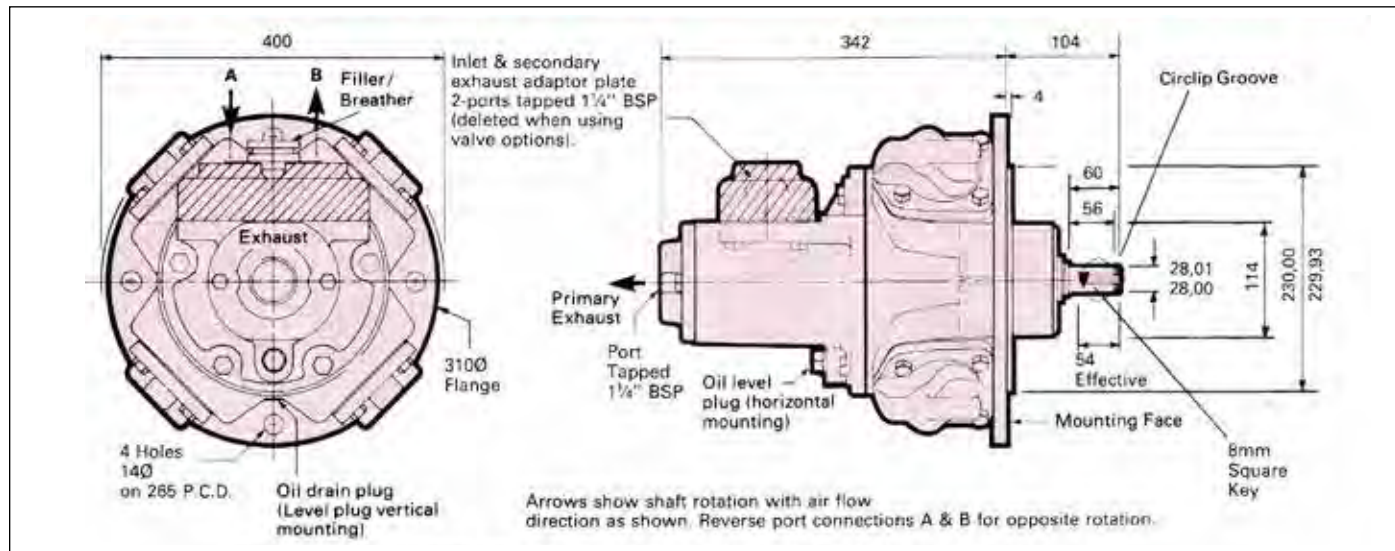

Reading graphs - Scales have been adjusted to enable bar and p.s.i. to be read from a common curve. Therefore only read p.s.i. with the left hand axis and bar with the right hand axis.

GRAPH 1 TORQUE - SPEED

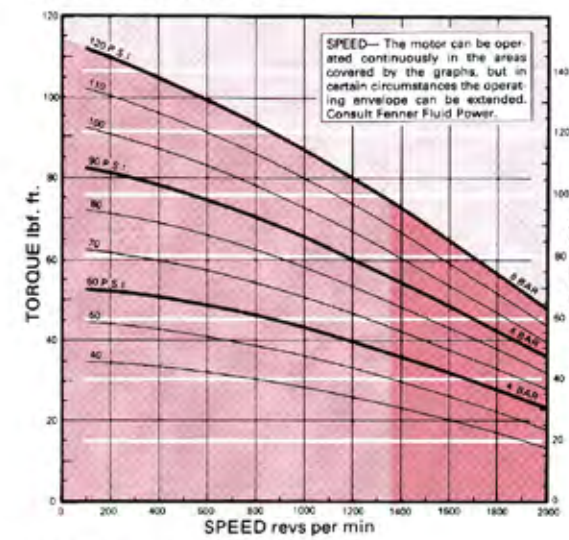

GRAPH 2 STARTING TORQUE - PRESSURE

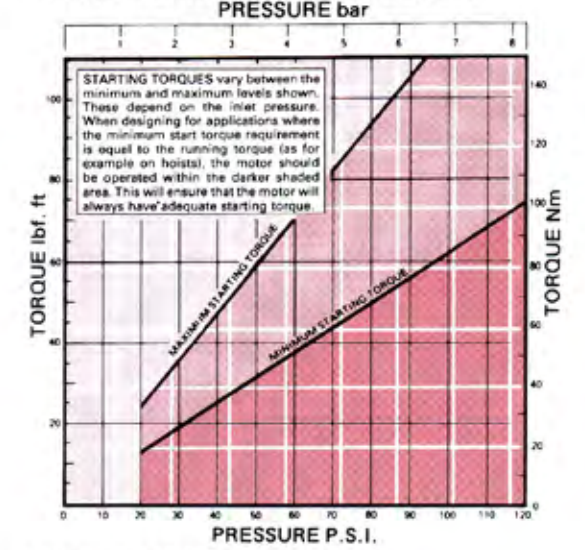

GRAPH 3 POWER - SPEED

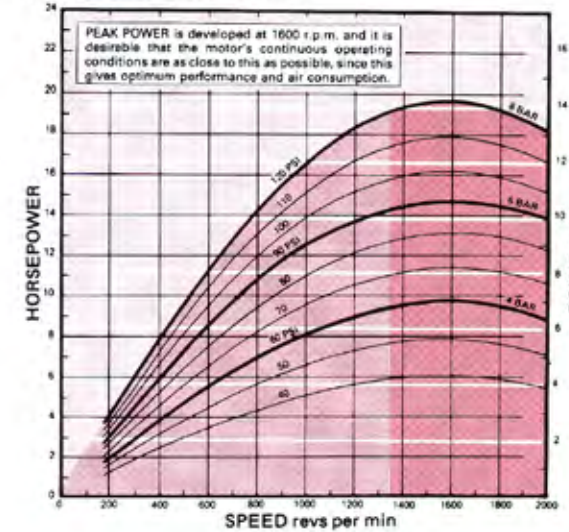

GRAPH 4 CONSUMPTION - SPEED

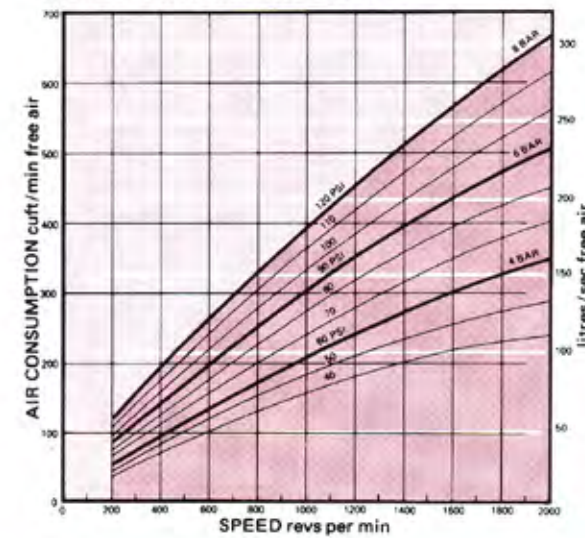

LUBRICATING OIL CAPACITIES

Horizontal 500 ml. Vertical 940ml.
Use a good quality hydraulic oil with a viscosity of around 100cSt (460SSU) at 40°C.

AIRLINE FILTRATION AND LUBRICATION

Use 64 micron filtration or better. Choose a lubricator suitable for the flow required. Prior to initial start-up, inject oil into the inlet port.

Lubricator drop rate: 3-4 drops / minute continuous operation.

Lubricator drop rate: 6-10 drops / minute intermittent operation.

MASS (MOTOR ONLY)

62 kg

MOMENT OF INERTIA

of rotating parts 4,1 gm²

MAX OVERHUNG FORCE SHAFT

1330 N.

TEMPERATURE RANGE

-20°C to +80°C

RM410 GEARED MOTOR INSTALLATION DETAILS

Maximum performance details listed below at 6 bar (90 psi). The performance under different conditions can be obtained by using the curves on page 162. A typical minimum gearbox efficiency of 90% can be expected. For higher pressures consult the manufacturer or their

distributors. The maximum overhung force is assumed acting midway along the output shaft; for other positions or higher loads on intermittent applications; consult the manufacturer of their distributors.

PERFORMANCE SUMMARY

Gearbox Ratio	Maximum Power Conditions					Approx. Min. Start Torque		Max. Cont.	Max. Overhung Force	
	Kw	hp	rpm	Torque		Nm	lbf. ft.	rpm	N	lbf.
				Nm	lbf. ft.					
2,8	10,5	14,1	578	168	128	189	145	722	6890	1550
4,5	10,5	14,1	360	271	206	304	232	449	7470	1680
7,2	10,5	14,1	222	438	334	493	376	277	8620	1940
11	10,5	14,1	148	656	500	738	563	185	9560	2150
14	10,5	14,1	113	857	654	964	736	142	10200	2300
18	10,0	13,4	88	1042	795	1172	894	111	16900	3800
24	10,0	13,4	67	1371	1046	1543	1177	84	17100	3850
28	10,0	13,4	57	1612	1230	1814	1383	71	18200	4100
37	10,0	13,4	44	2106	1607	2370	1807	55	20400	4600
61	10,0	13,4	26	3514	2680	3953	3015	33	24400	5500

BASE MOUNTED GEARBOX

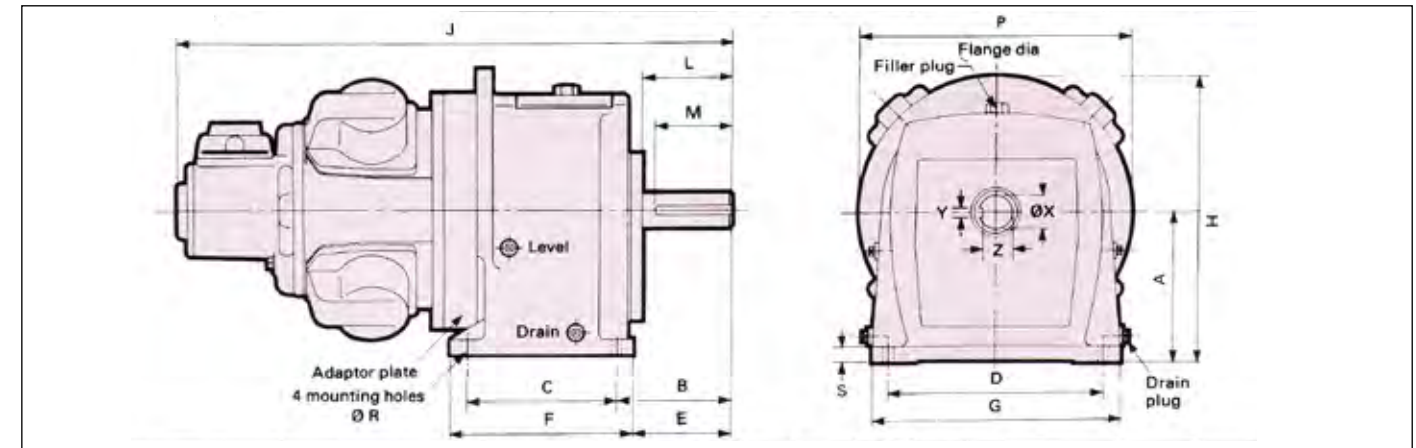

RATIO	A	B	C	D	E	F	G	H	J	L	M	P	R	X	Y	Z	MASS
2,8 to 14:1	190	151	195	275	125	246	320	365	716	105	100	350	14	45,02	13,98	39,5	146 kg
														45,00	39,3	39,3	
18 to 61:1	265	185	305	380	152	365	440	490	816	138	125	450	28	65,03	17,98	58,0	273 kg
														65,01	17,94	57,8	

FLANGE MOUNTED GEARBOX

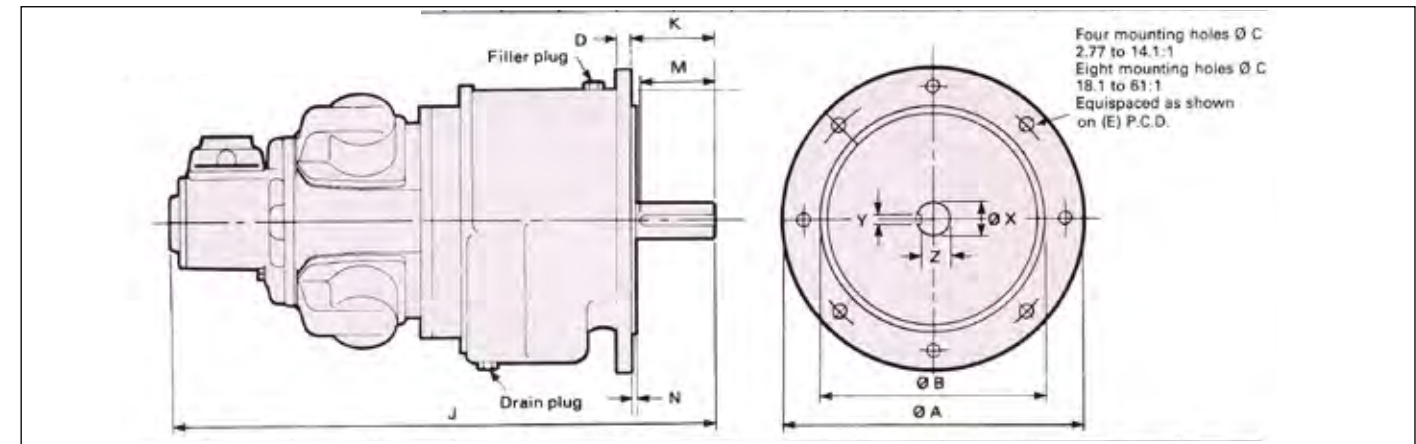

RATIO	A	B	C	D	E	J	K	M	N	X	Y	Z	MASS
2,8 to 14:1	400	300,00	4 x 18	19	350	716	110	100	6	45,02	13,98	39,5	146 kg
		299,92								45,00	13,94	39,3	
18 to 61:1	550	450,00	8 x 18	22	500	816	140	125	6	65,03	17,98	58,0	273 kg
		449,92								65,01	17,94	57,8	

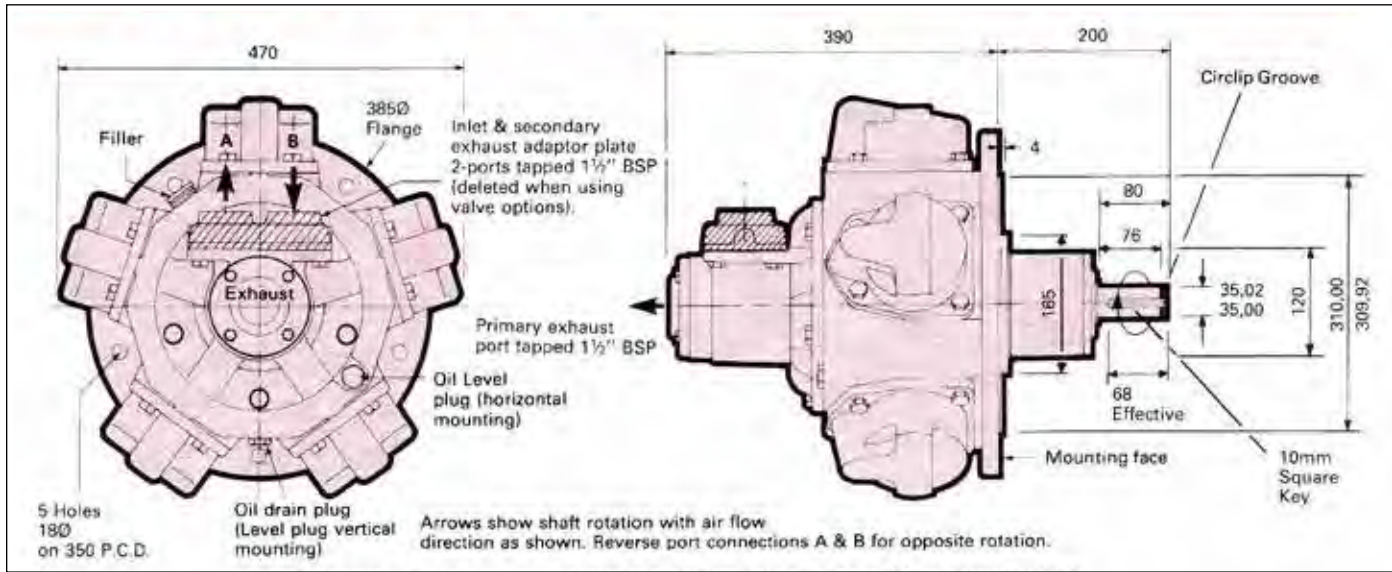

Reading graphs - Scales have been adjusted to enable bar and p.s.i. to be read from a common curve. Therefore only read p.s.i. with the left hand axis and bar with the right hand axis.

GRAPH 1 TORQUE - SPEED

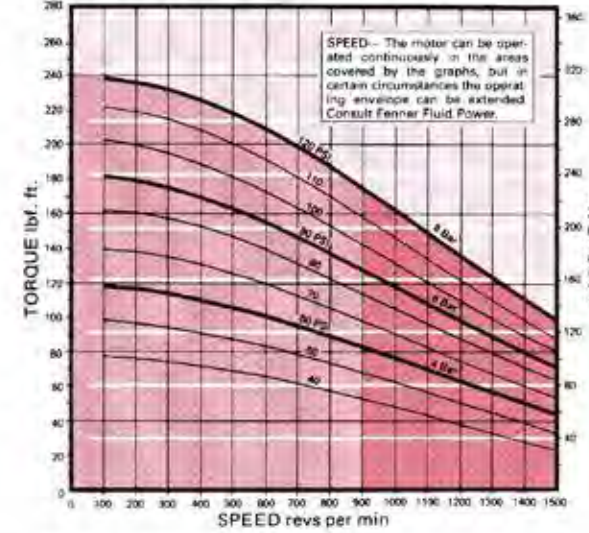

GRAPH 2 STARTING TORQUE - PRESSURE

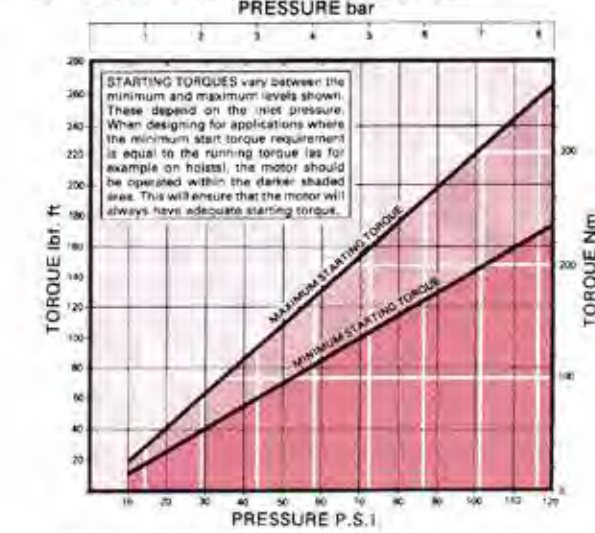

GRAPH 3 POWER - SPEED

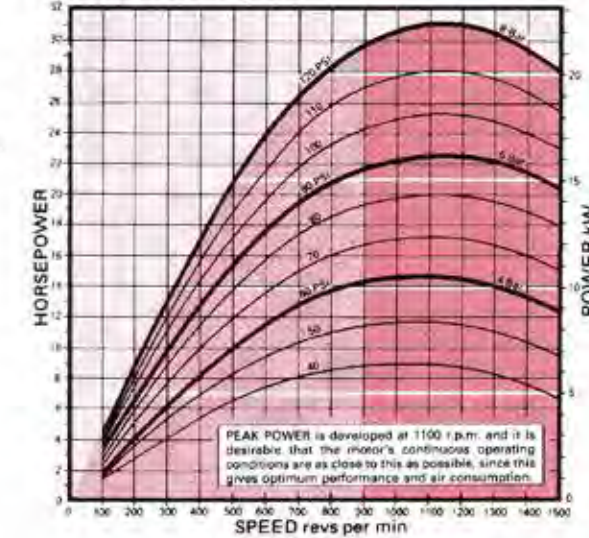

GRAPH 4 CONSUMPTION - SPEED

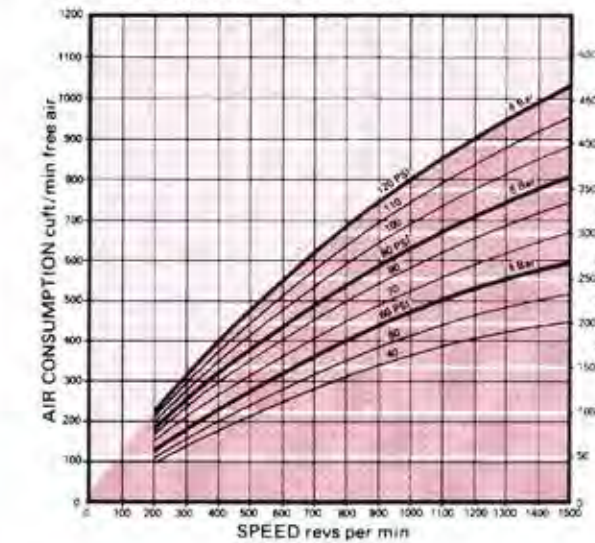

LUBRICATING OIL CAPACITIES

Horizontal 1,1 l. Vertical 2,1 l.

Use a good quality hydraulic oil with a viscosity of around 100cSt (460SSU) at 40°C.

AIRLINE FILTRATION AND LUBRICATION

Use 64 micron filtration or better. Choose a lubricator suitable for the flow required. Prior to initial start-up, inject oil into the inlet port.

Lubricator drop rate: 3-4 drops / minute continuous operation.

Lubricator drop rate: 6-10 drops / minute intermittent operation.

MASS (MOTOR ONLY)

115 kg

MOMENT OF INERTIA

of rotating parts 14 gm²

MAX OVERHUNG FORCE SHAFT

6500 N.

TEMPERATURE RANGE

-20°C to +80°C

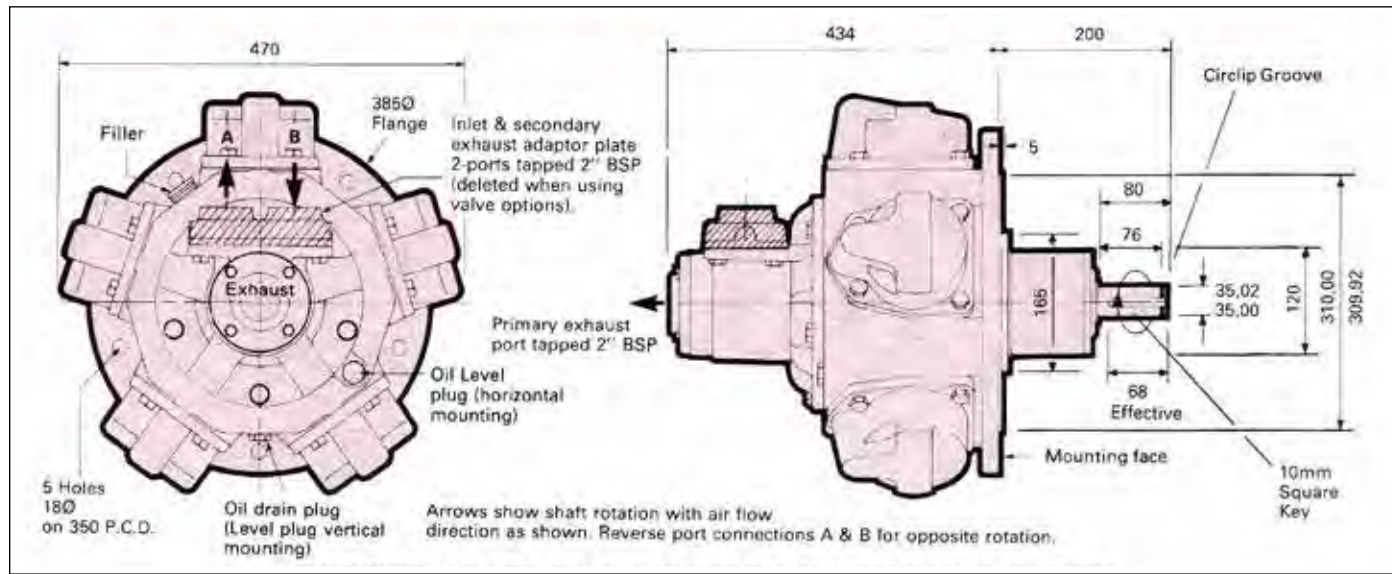

Reading graphs - Scales have been adjusted to enable bar and p.s.i. to be read from a common curve. Therefore only read p.s.i. with the left hand axis and bar with the right hand axis.

GRAPH 1 TORQUE - SPEED

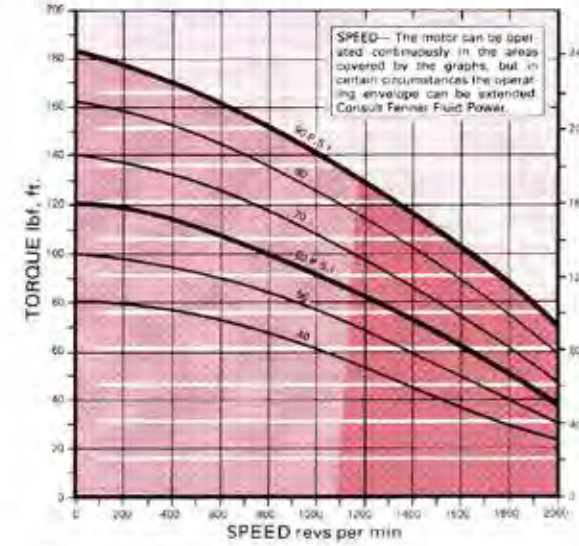

GRAPH 2 STARTING TORQUE - PRESSURE

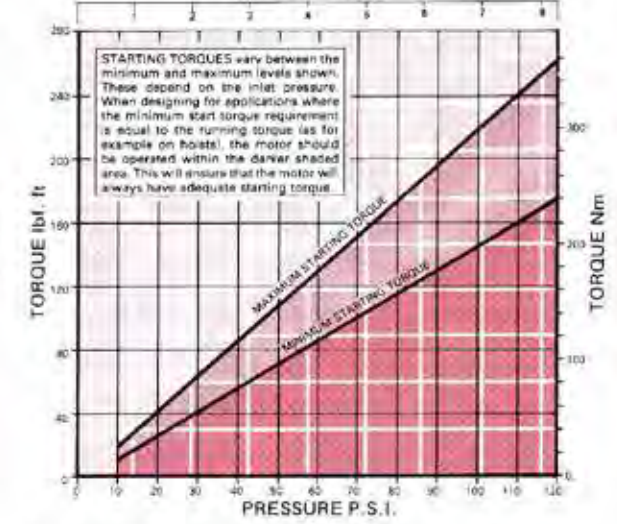

GRAPH 3 POWER - SPEED

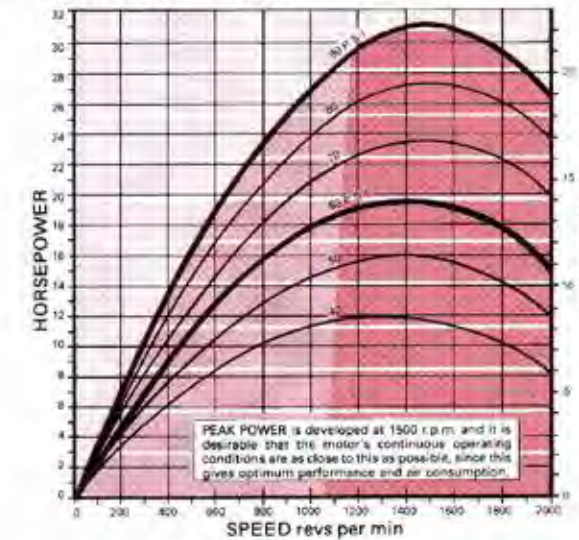

GRAPH 4 CONSUMPTION - SPEED

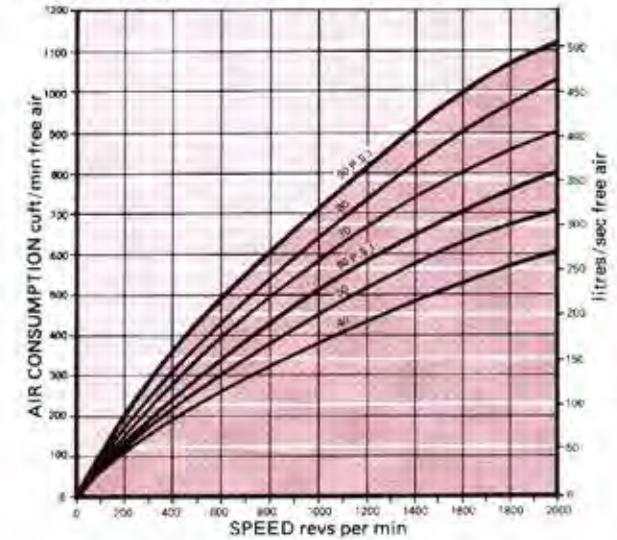

LUBRICATING OIL CAPACITIES

Horizontal 1,1 l. Vertical 2,1 l.

Use a good quality hydraulic oil with a viscosity of around 100cSt (460SSU) at 40°C.

AIRLINE FILTRATION AND LUBRICATION

Use 64 micron filtration or better. Choose a lubricator suitable for the flow required. Prior to initial start-up, inject oil into the inlet port.

Lubricator drop rate: 3-4 drops / minute continuous operation.

Lubricator drop rate: 6-10 drops / minute intermittent operation.

MASS (MOTOR ONLY)

125 kg

MOMENT OF INERTIA

of rotating parts 14 gm²

MAX OVERHUNG FORCE SHAFT

6500 N.

TEMPERATURE RANGE

-20°C to +80°C

FOOT BRACKETS AND SILENCERS

FOOT BRACKET FOR RM- 050, 210, 310, 410

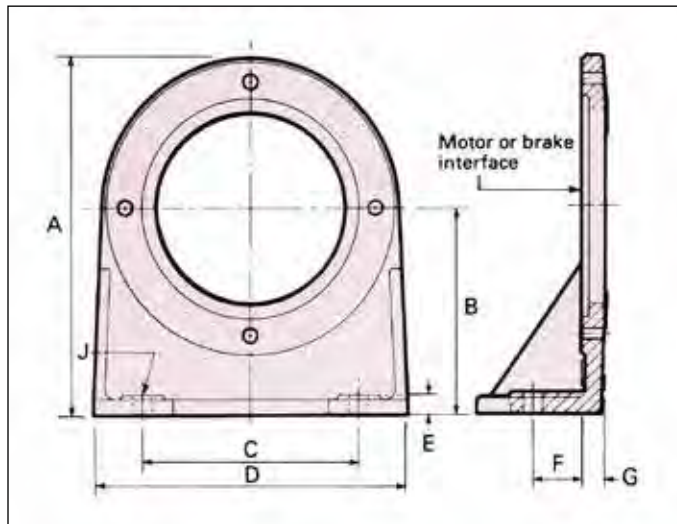

FOOT BRACKET FOR RM- 510, 610

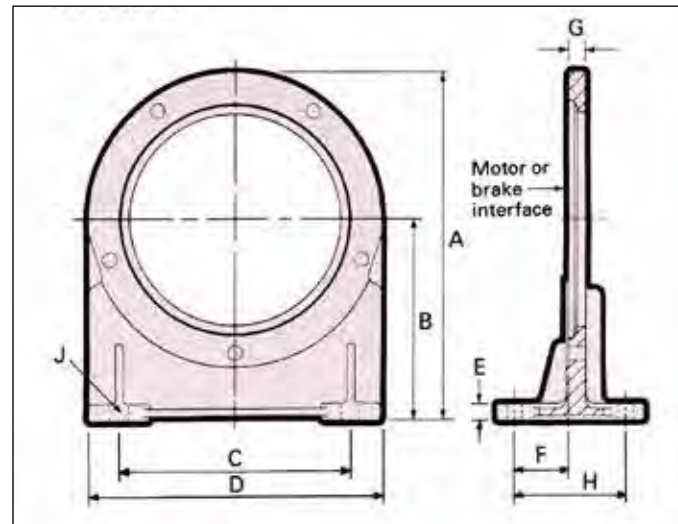

	050	110	210	310	410	510	610
A	220	220	310	370	372	457	457
B	125	125	180	215	215	264	264
	124,5	124,5	179,5	214,5	214,5	263,5	263,5
C	140	140	190	228	228	305	305
D	203	203	280	330	330	386	386
E	10	10	20	19	21	22	22
F	32	32	42	52	52	70	70
G	16	16	19	22	22	22	22
H	-	-	-	-	-	146	146
J	2 x Ø 14	2 x Ø 14	2 x Ø 18	2 x Ø 20	2 x Ø 20	2 x Ø 22	2 x Ø 22

SILENCERS

Silencers screw directly into the primary and secondary exhaust ports. Note - control valves all have secondary exhaust ports. Please contact us for more information and possibilities regarding the silencers.

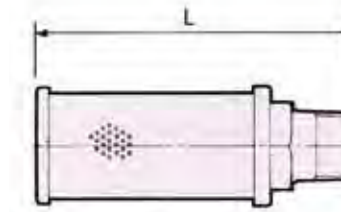

Normally supplied in kit form complete with fittings.



VALVE OPTIONS

This range of bolt on valves offers very sensitive speed and directional control. One frictionless matched spool and sleeve assembly is offered with two alternative means of actuation.

CONFIGURATION

As standard these valves can be supplied with either EQUAL POWER OR BAISED POWER spools, the latter is suitable for hoisting applications (normal power for lifting - reduced power for lowering). The direction of reduced power must be stated when ordering CW or CCW, when viewed on the output shaft of the motor or geared motor.

1. REMOTELY CONTROLLED (RCV) - This option is usually controlled from a remote position by one of the PC series or LC2 units shown opposite. A variable air pilot signal is applied to either end of the valve spool, depending on the required direction of motor rotation. The pilot pressure range is between 1.4 bar (20 psi) and 4.8 bar (70 psi), increased pilot pressure gives increased speed. The valve is spring centred to neutral.

2. HAND CONTROLLED (HCV) - The control valve spool is operated directly by a lever mechanism. Speed increase is obtained as the lever is moved in either direction from the centre (neutral) position.

PRESSURE DROP

Minimal pressure drop will be experienced through the valves, having the effect of maintaining the output torque whilst reducing the motor output speed by approximately 10-15% at 6 bar (90 psi) at maximum power. The starting torque remains unaffected.

REMOTE CONTROL VALVE

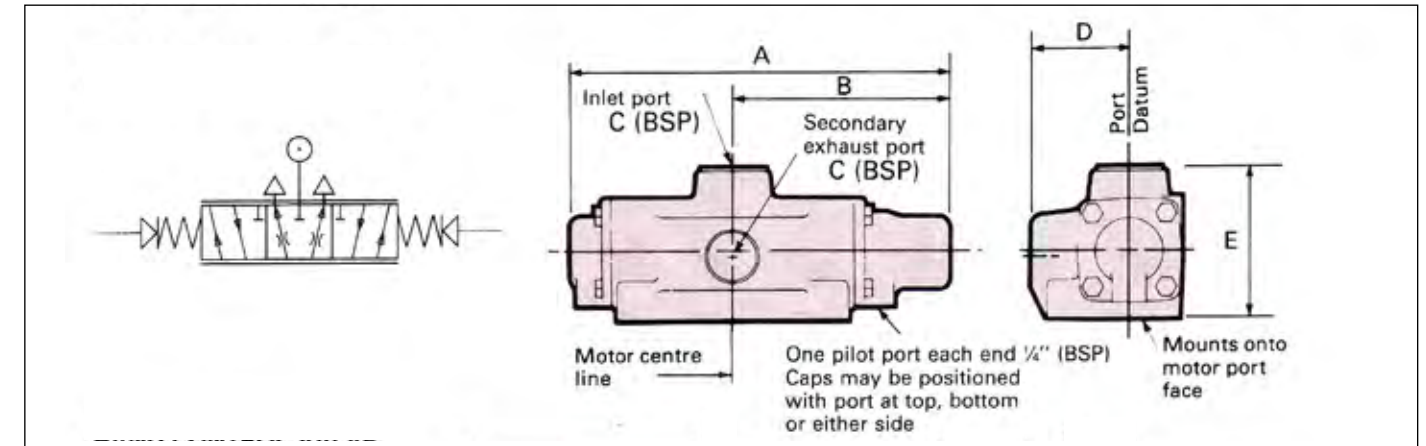

HAND CONTROL VALVE

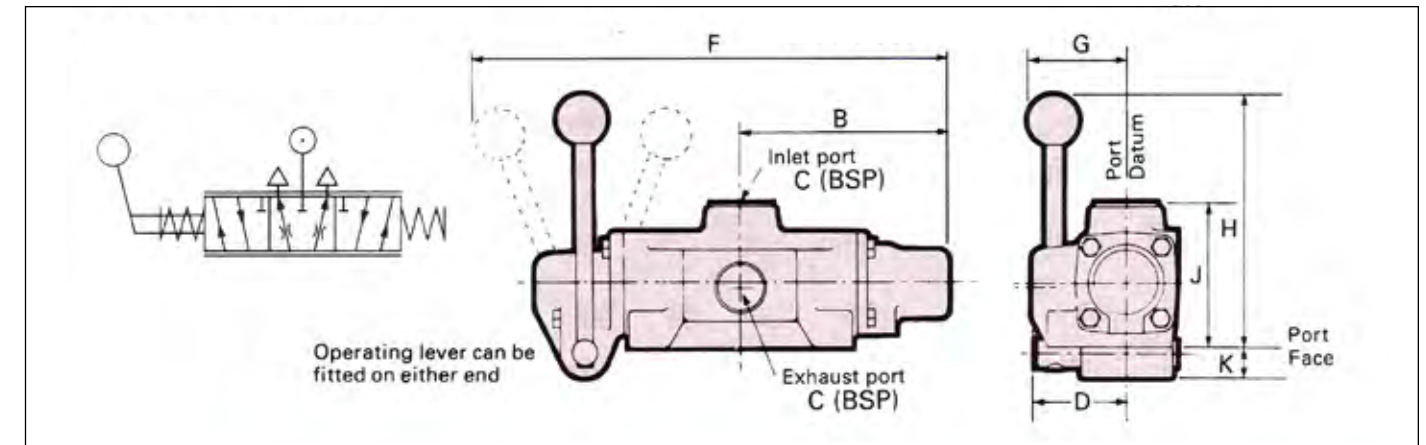

Motors	A	B	C (BSP)	D	E	F	G	H	J	K
050 & 110	210	118	1/2"	61	84	270	61	162	84	21
210	210	118	3/4"	61	84	270	61	162	84	21
310	280	160	1"	72	103	365	75	193	103	27
410	280	160	1 1/4"	72	114	365	75	198	112	22
510	355	197	1 1/2"	97	137	413	90	190	137	27
610	355	197	2"	97	137	413	90	190	137	27

PENDANT CONTROLS (PC2, 4 OR 6)

The PC2, 4 and 6 remote controllers are designed specifically for use with the RCV modules previous. They provide the correct range of pilot pressure required to operate the RCV units, and give excellent control of motor speed. The PC2 is used to control one (hoist) motor; the PC4 can control two motors independently (say hoist and long travel); the PC6 can control three motors independently (hoist, long travel, traverse). Motors of different sizes can be controlled from the same unit.

Control line lengths up to 36m (120ft) give excellent response. For distance in excess of this consult the manufacturer or distributors. The control lines are small bore eliminating the need for large capacity air supply lines between motor and controllers. If required, supply pressure can be taken from the port on the RCV.

MARINE VERSIONS AVAILABLE. PC2M, PC4M OR PC6M



PENDANT CONTROLS

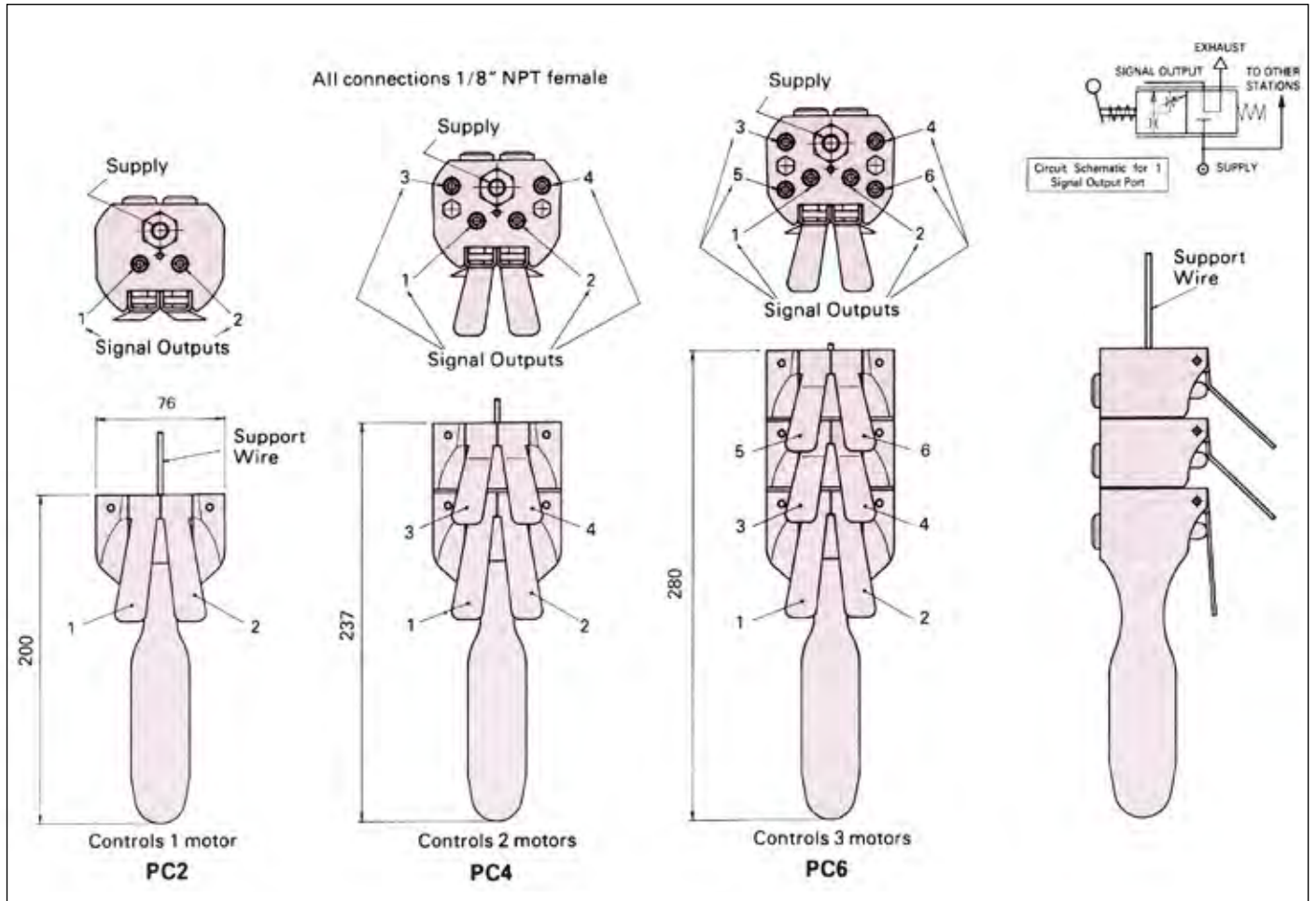

LEVER CONTROL (LC2) MARINE STYLE (LC2M)

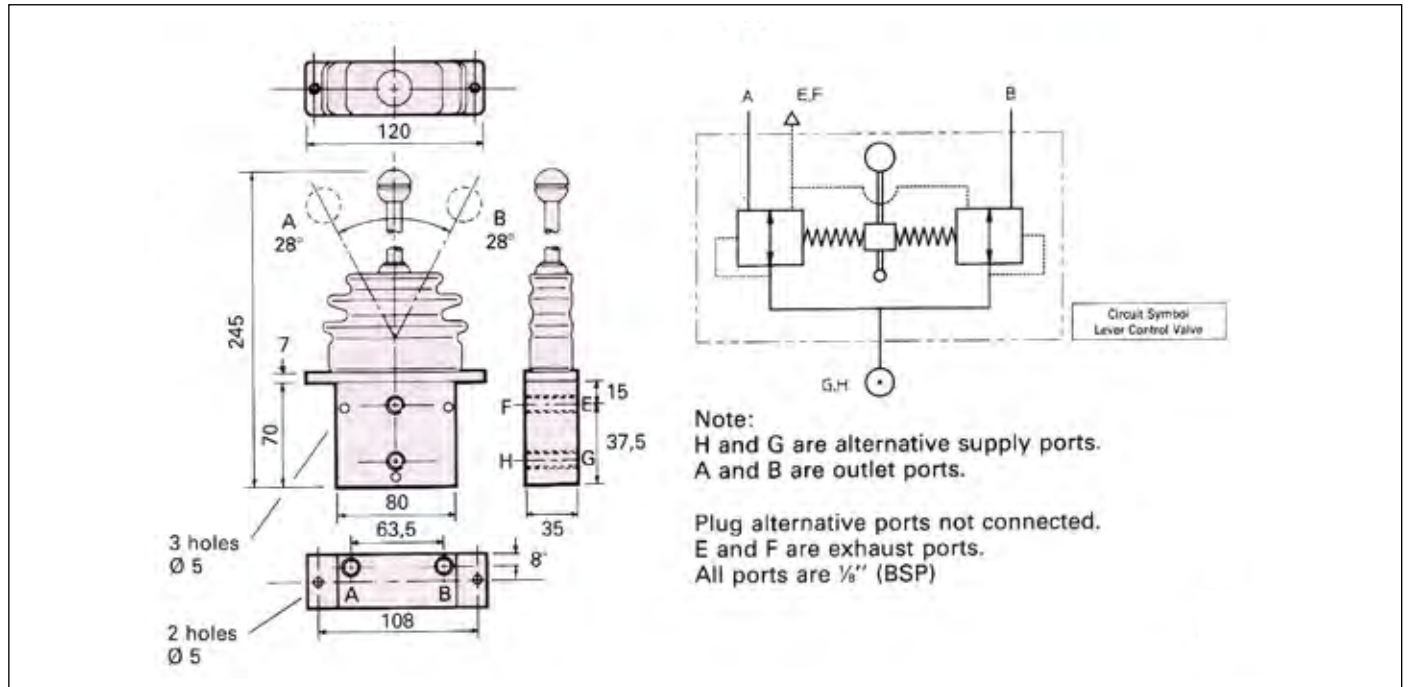

BRAKE INSTALLATION DETAILS

The brake module bolts directly into the motor mounting face and has exactly the same interface as the motor. As shown on the drawing below, the brake consists of two spring applied shoes pressed against a central hub. These shoes are released by applying air pressure to the cylinder/piston assembly. The brake torque can be varied

by means of two spring adjusters but it is normally set that a pilot pressure of 4.1 (60 p.s.i.) will fully release it. Pressures below this level will progressively reduce the braking torque available. The brakes are set at the factory but it may be necessary to make adjustments on site to suit the individual application.

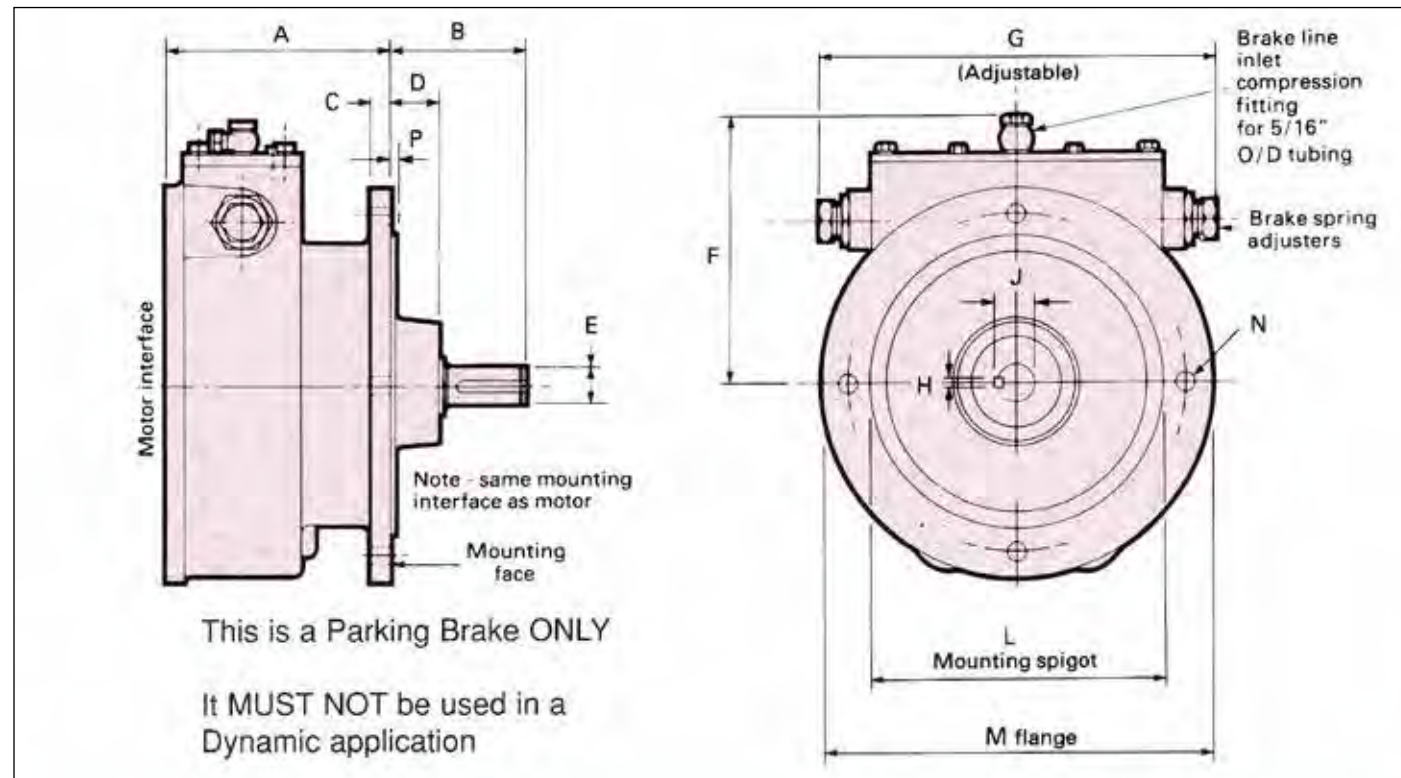

Motors	A	B	C	D	E	F	G	P
050	100	66	8	30	14,01 14,00	126	210	3,6
110	100	66	8	30	14,01 14,00	126	210	3,6
210	115	93	11	46	19,01 18,99	129	235	4,0
310	140	104	15	46	22,01 21,99	160	270	4,0
410	175	104	16	37	28,01 28,00	206	340	4,0
510	172	96	16	16	35,02 35,00	268	450	5,1
610	172	96	16	16	35,02 35,00	268	450	5,1

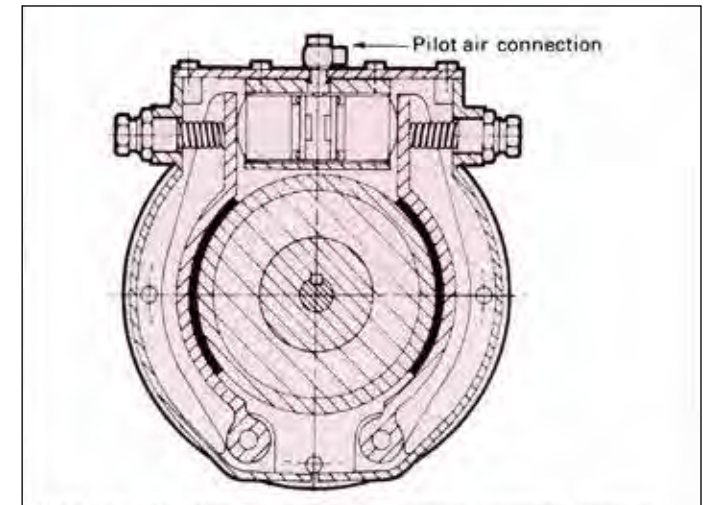
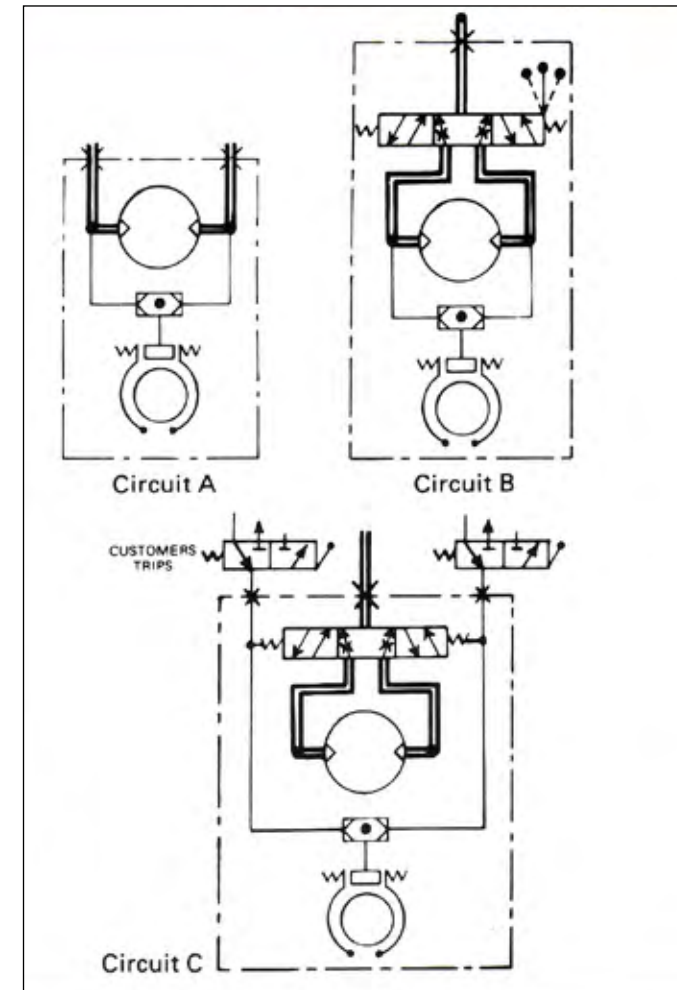

- CIRCUIT (A)** - Applies to braked motors supplied without control valving. The unit will be fitted with a shuttle valve to allow brake operation for dual rotation.
- CIRCUIT (B)** - Units supplied with hand (HCV) controlled reversible valves. If trips are required they must be of the mechanical style (customers supply).
- CIRCUIT (C)** - Units supplied with remotely controlled valves. When override trips are required, they must be superimposed in the signal line close to the motor unit and be of the 3 way style. (Signal lines cut and exhausted in the tripped position).

H	J	L	M	N-MOUNTING HOLES			
				NO.	Ø	P.C.D.	BOLT LENGTH (MAX)
5,00	16,00	130,00	188	4	11	165	28
4,97	15,87	129,94					
5,00	16,00	130,00	188	4	11	165	28
4,97	15,87	129,94					
6,00	21,50	180,00	254	4	14	215	25
5,97	21,27	179,94					
8,00	31,01	230,00	305	4	14	265	40
7,94	37,71	229,93					
10,00	38,00	310,00	385	5	18	350	35
9,96	37,71	309,92					
10,00	38,00	310,00	385	5	18	350	35
9,96	37,71	309,92					



COMPACT PISTON AIR MOTORS

WORKING PRINCIPLE

The compact radial piston air motor operates without rod or crank shaft. The radial arranged pistons travel along a curve and are controlled by the centre.

The static control shaft supplies the driving pistons with the necessary air. Air supply and release openings along the static shaft are periodically opened and closed by the rotation of the rotor to pressurize or release the pistons in an appropriate sequence.

Six of the twelve driving pistons are actively contributing to the torque at any moment. Once reaching the highest point on the curve, the air driving the piston is released by the control unit and the piston is forced into its lowermost position. This operating principle is equivalent with the one of a simple cylinder.

The compact piston air motor's high torque is due to the power transmission of the pistons along the large external diameter of the curve. The friction connected with the travel along the curve is low due to the installation of rollers at the tip of the pistons. This results in high lifetime of the drive.

Noise emissions were determined according to the noise measuring standards ISO 11202 and within the frame of the ISO 11200 standards. The measured noise levels were below 78 dB for the RM012 and RM024. The pneumatic drive thus fulfils the noise regulations without requirement for ear protection devices.

We recommend to operate the drive within a speed range of 50 - 350 R.P.M. shaft dimensions can be adapted according to the specific requirements of the client. Dimensions in millimetres.

CROSS SECTION COMPACT PISTON AIR MOTOR

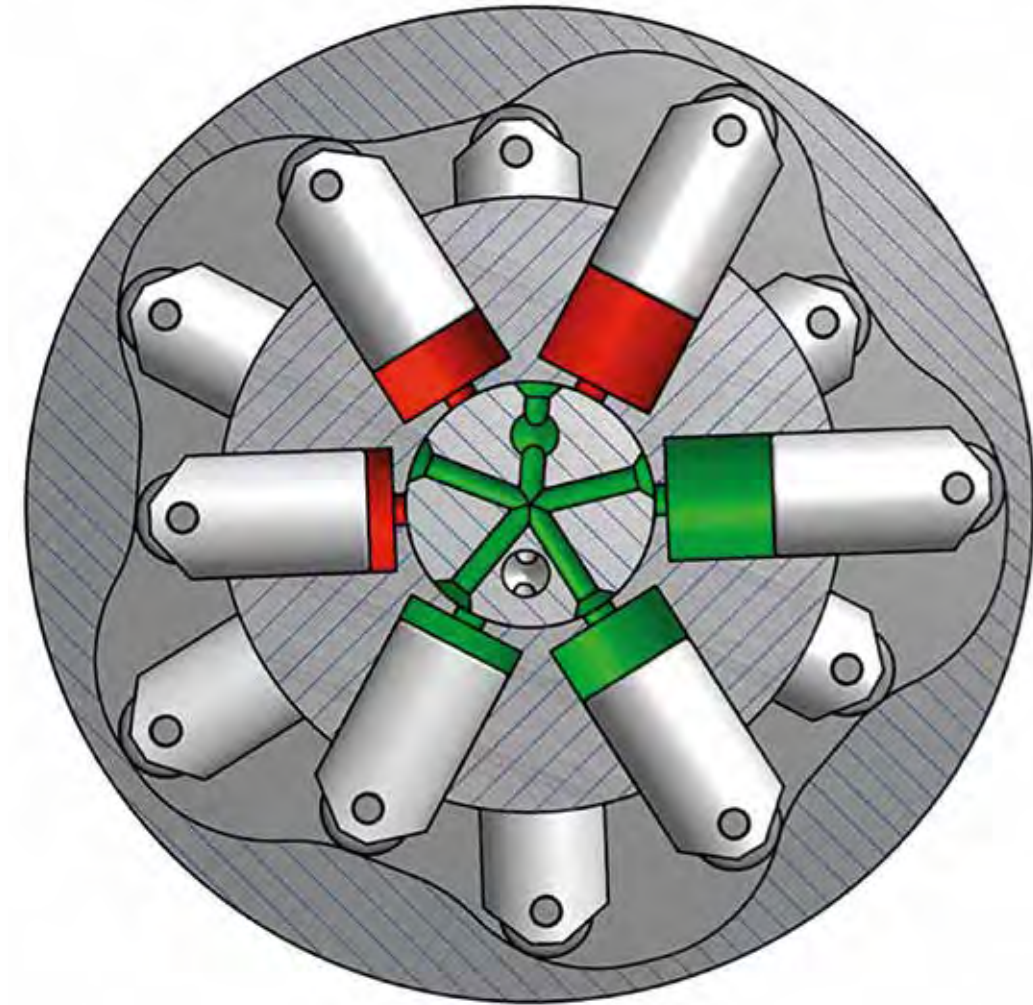

WHY CHOOSE A COMPACT PISTON AIR MOTOR?

Within the air motor family the compact piston air motor takes a special place, because this motor is often used in applications where other air motors can not be used.

- High torque at low speed of rotation. Therefore most of the times a gearbox is not necessary.
- Highest torque at start-up. The compact piston air motor does not have a variable starting torque. This always guarantees the rated starting torque.
- Very low air consumption due the use of pistons, low internal friction and low internal air leakage.
- Low noise emission that fulfils the noise regulations without requiring ear protection.
- The compact piston air motors can be supplied directly coupled to a wide range of gearboxes such as planetary, helical bevel helical and worm gears.
- Due to the low speed of rotation the compact piston air motor is especially suitable for applications in which the air motor is constantly in stall.
- Compact construction made out of aluminium with steel shaft. Also available in a plastic housing with a stainless steel shaft.
- Integrated brake function. When both the inlet and outlet port are pressurised, the motor functions as a brake with a torque that is 50% of the starting torque.
- Able to run without lubrication. The compact piston air motors can operate with a minimum of lubrication. Complete oil-less operation is possible in certain applications. Consult GLOBE Airmotors BV or your local distributor for more information.

ADVANTAGES

Air motors offer a unique form of drive and incorporate advantages not found in other prime movers.

- Simple and inexpensive variable speed and torque control with a flow control valve and/or pressure regulator.
- Intrinsically safe for explosion proof environments. The compact piston air motors are certified according to the European explosion directive ATEX II cat. 2 G&D T5.
- Air motors can be stalled indefinitely under load. They will not overheat or burn out.
- Long lifetime because of low friction and a minimum of parts that are exposed to wear.
- Controllable over a wide speed range.
- Instantly reversible, operated with a simple control valve.
- Resistant to warm, dirty and damp conditions.
- No shock start up which improves the life span of the equipment.
- 12 pistons (7 pistons for the RM004) and smooth running.
- Improved design pistons for longer life time.
- Oil free running.
- Silicone free so very useful in mixing applications.
- Available with front flange, which incorporates an extra bearing.
- Small dimensions.
- Special version for food and chemical industry.

AIR SUPPLY**AIR QUALITY**

To insure optimal working conditions for the GLOBE piston air motors, the air supply must be dry, filtered and lubricated. A 5 micron filter or better is recommended. The GLOBE piston air motors should be lubricated sufficiently. Oilless operations are possible in certain applications.

AIR LINE RESTRICTIONS

Air line restrictions on the inlet side of the motor will result in performance loss. Therefore it is important to make sure that the desired air pressure is available at the motor during operation. The pressure reading at the compressor or pressure regulator may be different then the pressure available at the motor. Performance loss can also occur by an exhaust restriction generating back pressure on the outlet side of the motor. An insufficiently sized silencer, valve or coupling is usually the cause.

GEARED VANE AIR MOTORS

Although air motors can be adjusted over a wide range of speed and torque, the output characteristics are not always suitable for the application. To achieve the required output speed and torque a gearbox can be coupled directly to the air motor.

GLOBE Airmotors BV has a wide range of gear units such as planetary, helical, beval helical and worm gears in their program. Consult GLOBE Airmotors BV or your local distributor for more detailed information.



ORDERING CODES COMPACT PISTON AIR MOTOR

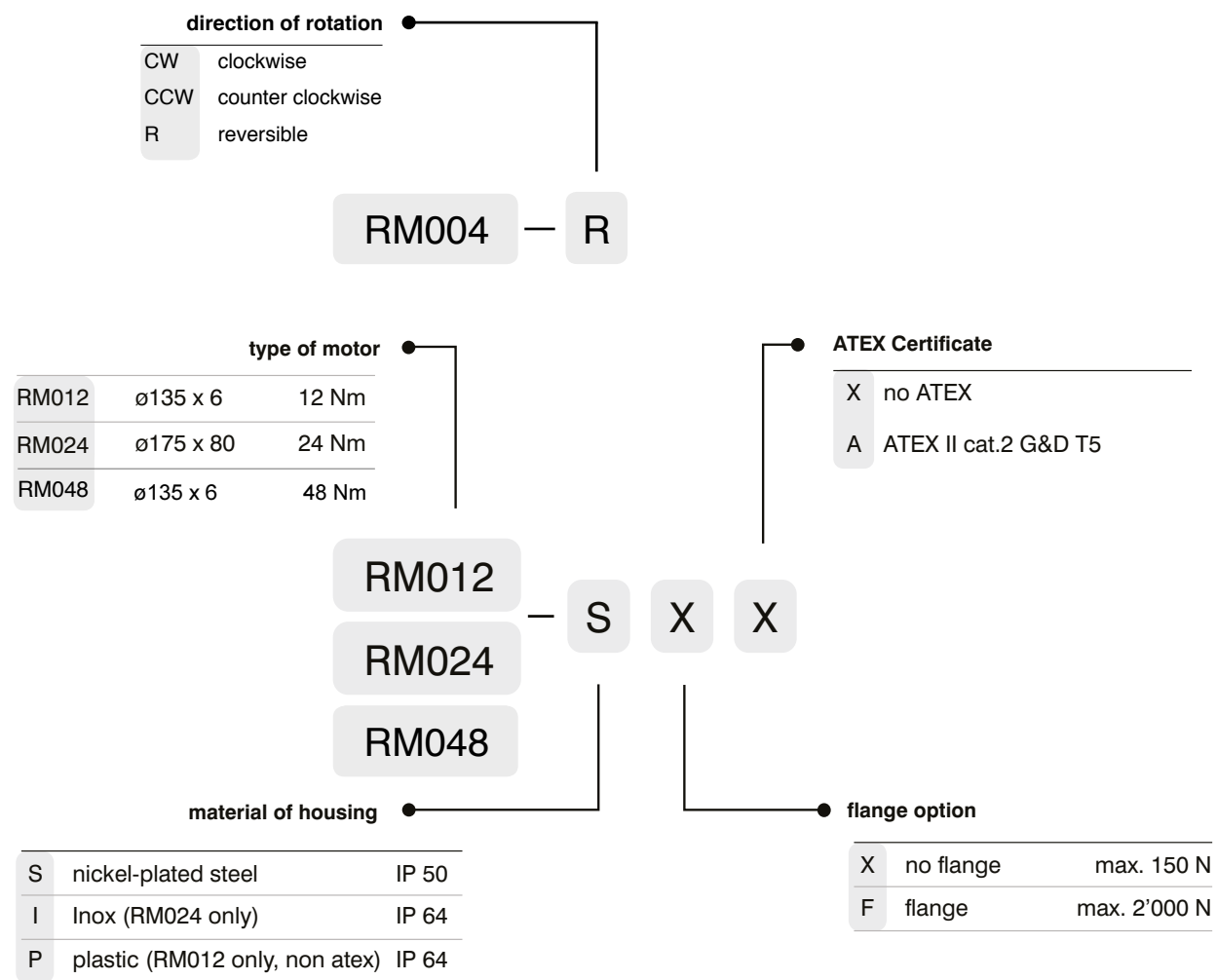

POSSIBLE TYPES

- RM004R / CW / CCW Steel housing
- RM012 / RM024 / RM048 -SXX Steel housing
- RM012 / RM024 / RM048 -SFX Steel housing and flange
- RM012 / RM024 / RM048 -SXA Steel housing ATEX
- RM012 / RM024 / RM048 -SFA Steel housing, flange, ATEX
- RM012 -PXX Plastic housing, water resistant, stainless shaft and covers
- RM012 -PFX Plastic housing, flange with extra bearing, water resistant, stainless shaft and covers
- RM024 / RM048 -IXX Inox housing, water resistant, stainless shaft and covers
- RM024 / RM048 -IFX Inox housing, flange, water resistant, stainless shaft and covers
- RM048 -IXA Stainless steel housing, water resistant, stainless shaft and covers, ATEX
- RM048 -IFA Stainless steel housing, water resistant, stainless shaft and covers, ATEX



DIMENSIONS RM004 CW, CCW

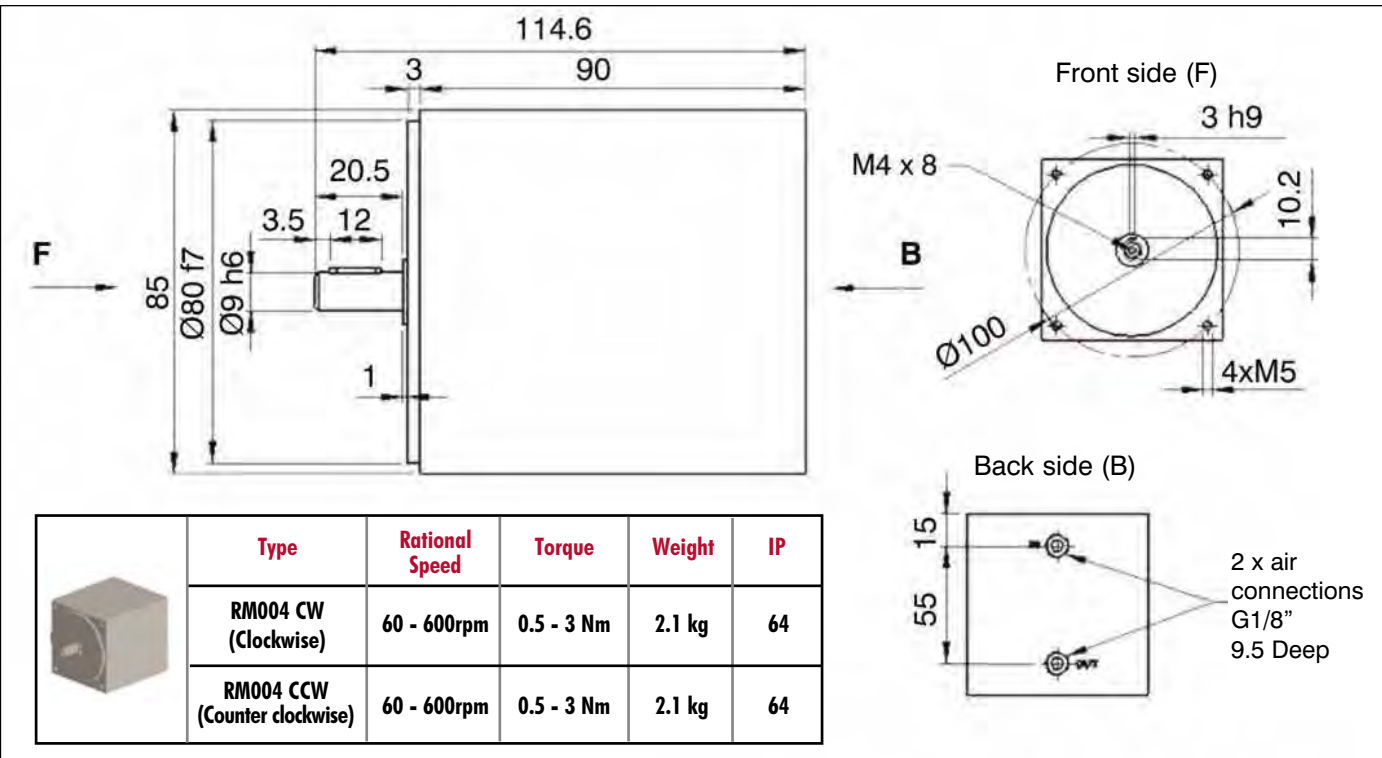

PERFORMANCE RM004

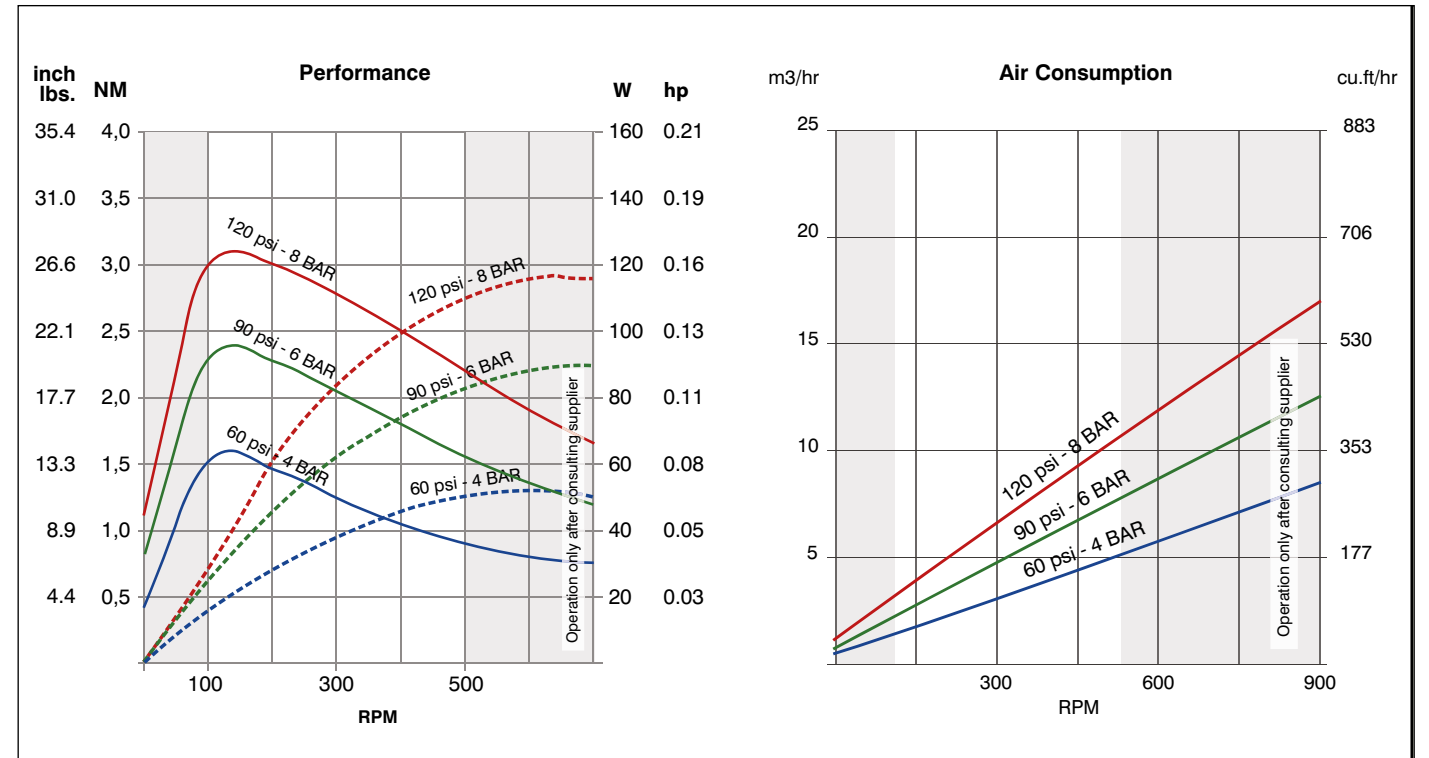

DIMENSIONS RM004 - R REVERSIBLE

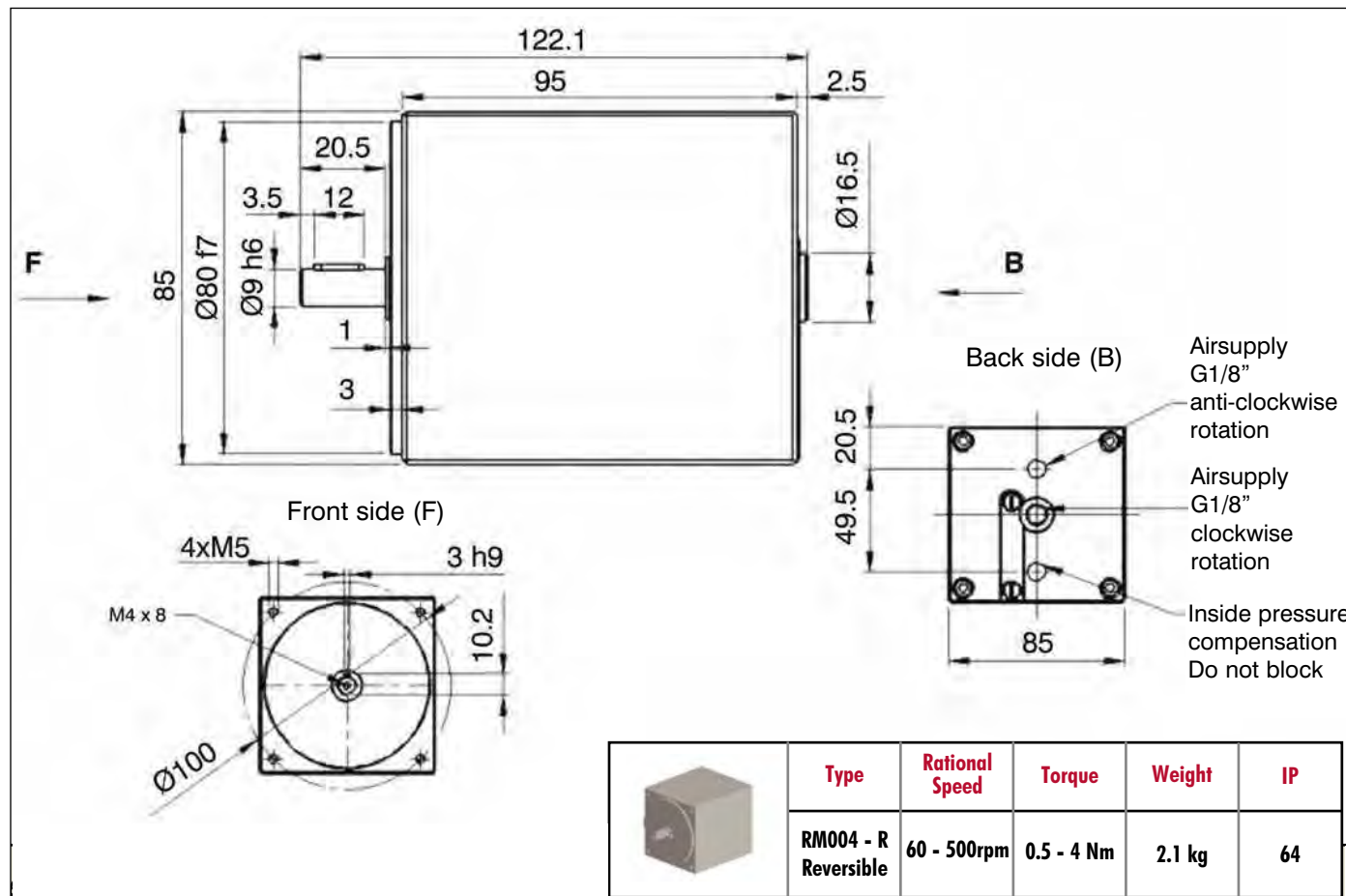

DIMENSIONS RM012 - SXX, PXX, SXA ATEX

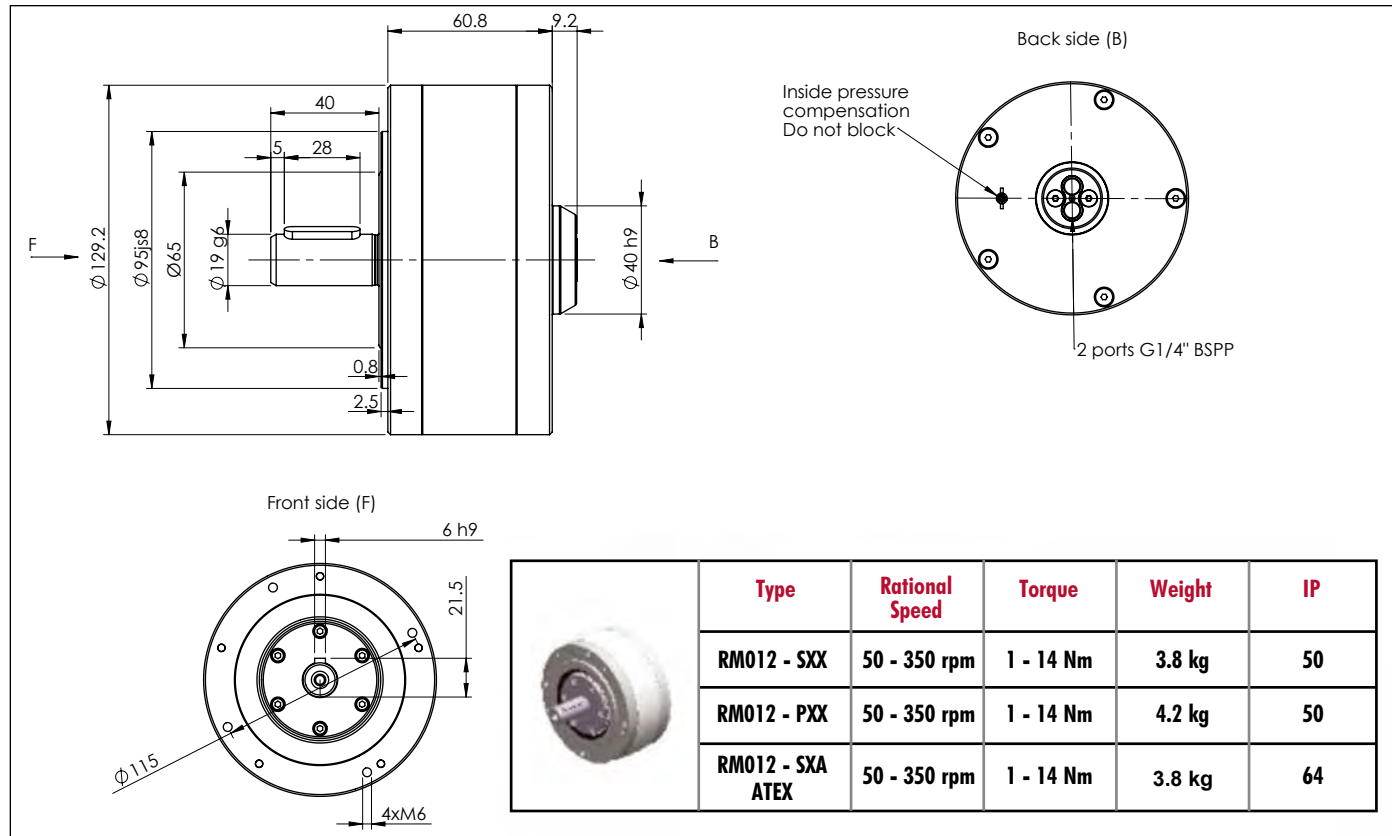

PERFORMANCE RM012

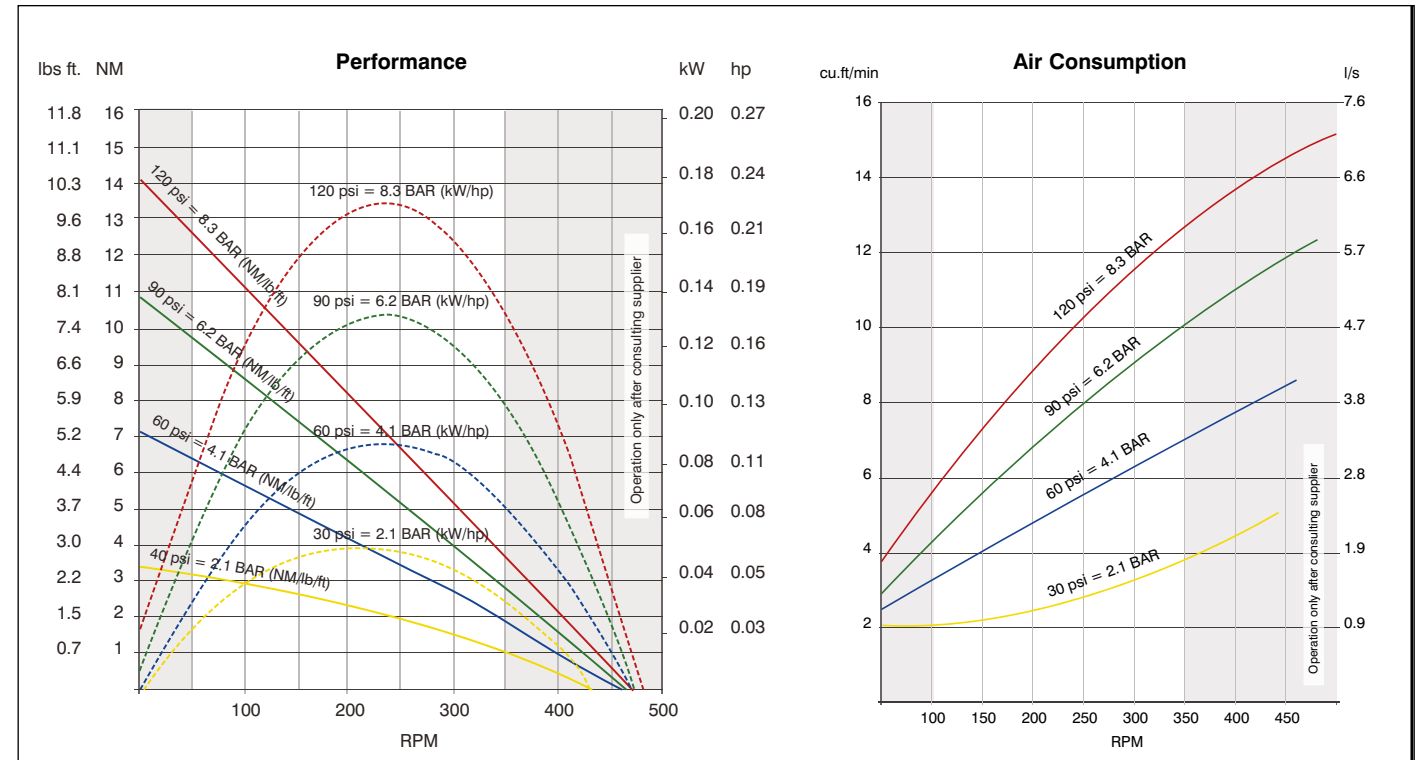

DIMENSIONS RM012 - SFX, PFX, SFA ATEX

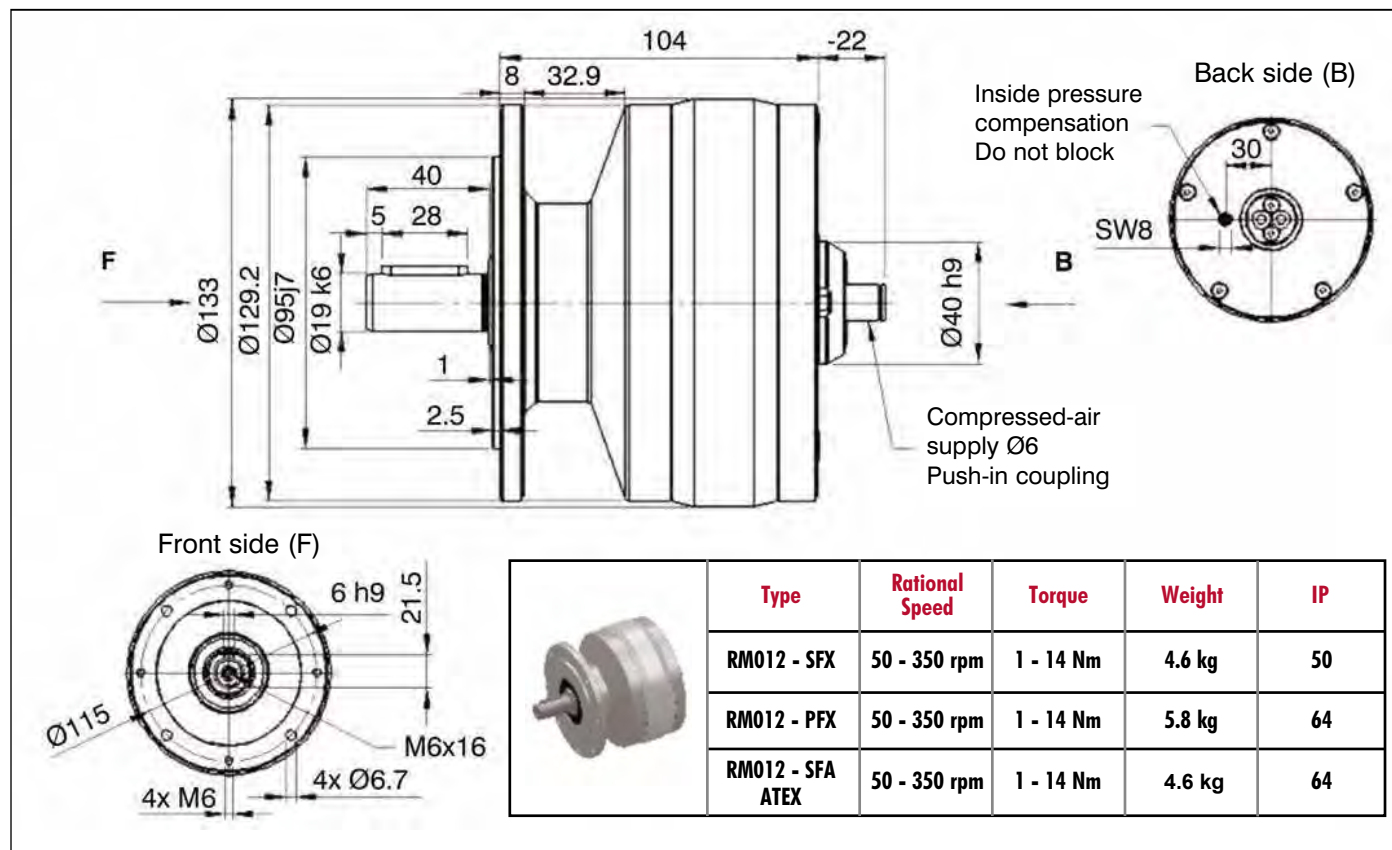

LOAD DIAGRAM FOR RM012 SFA, SFX, PFX

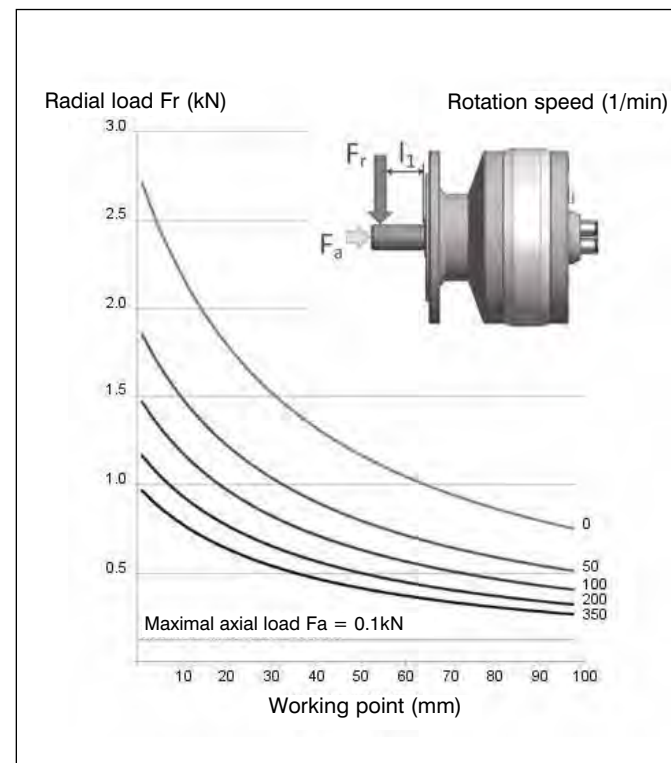

LOAD DIAGRAM FOR RM012 SXX, SXA, PXX

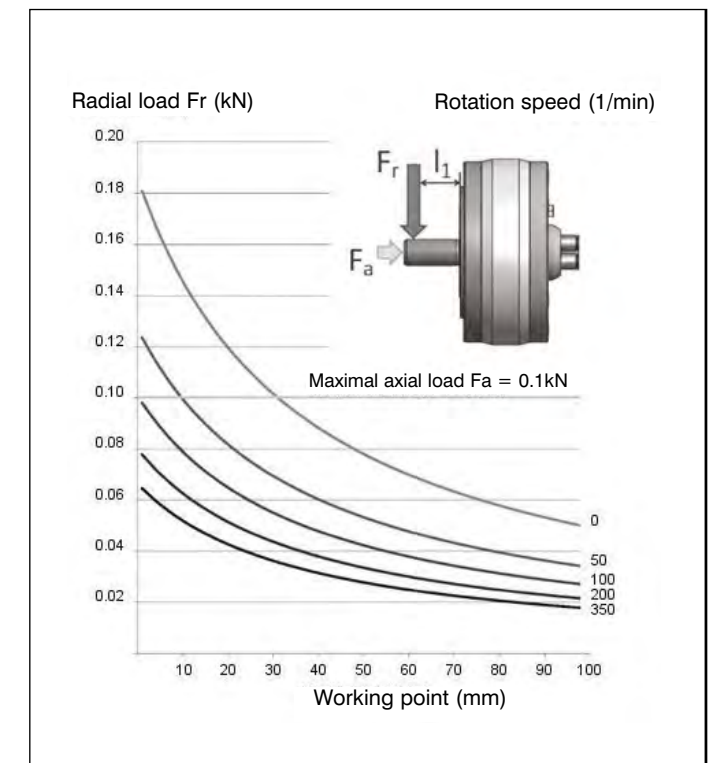

DIMENSIONS RM024 - SXX, IXX, SXA ATEX

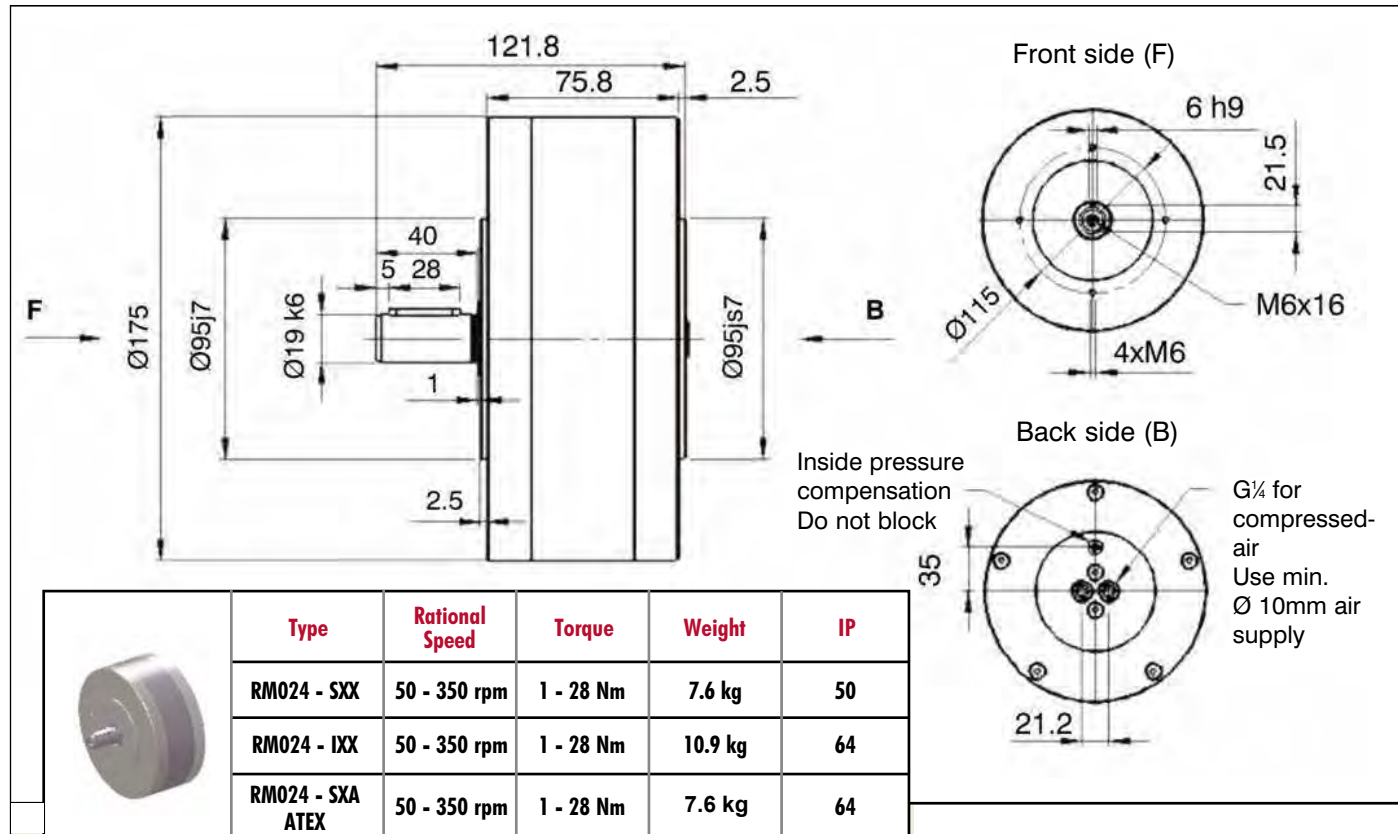

PERFORMANCE RM024

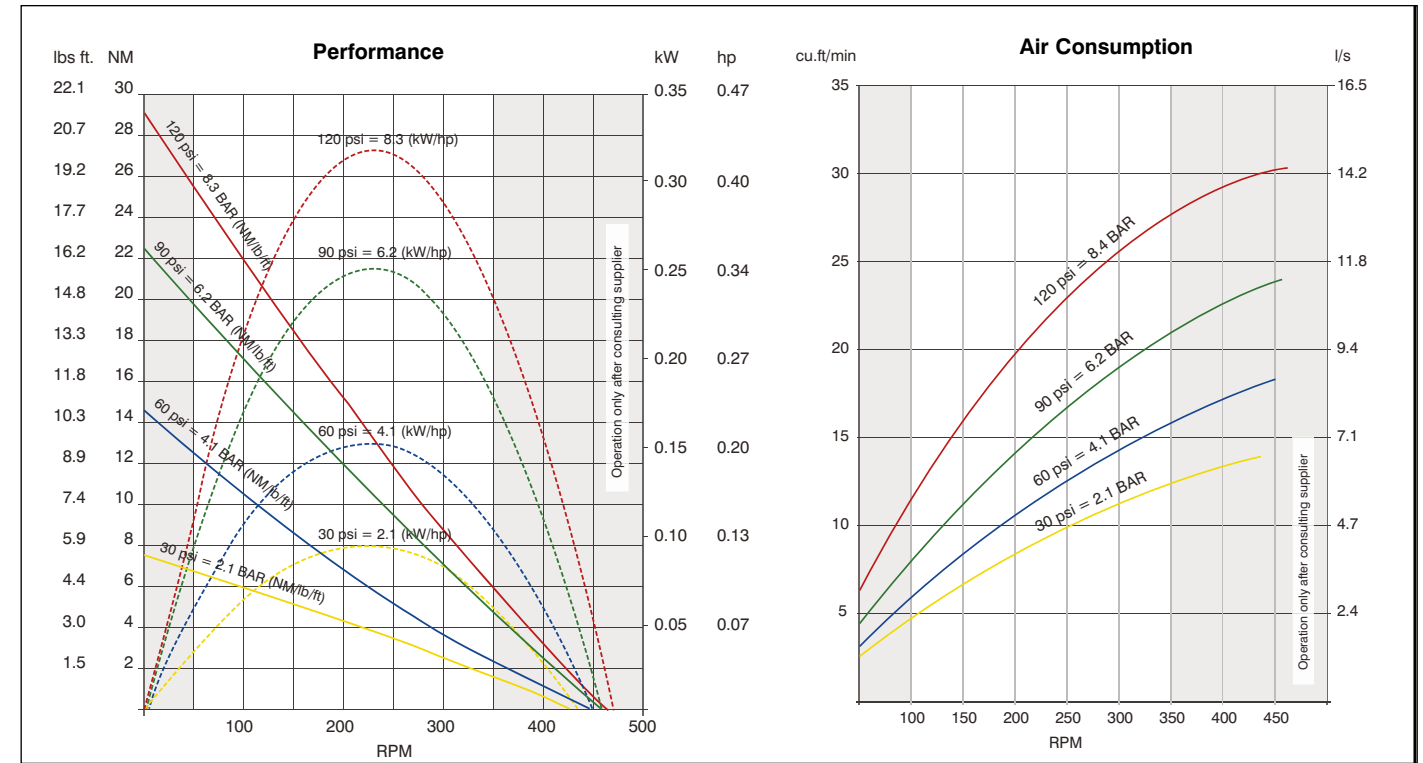

DIMENSIONS RM024 - SFX, IFX, SFA ATEX

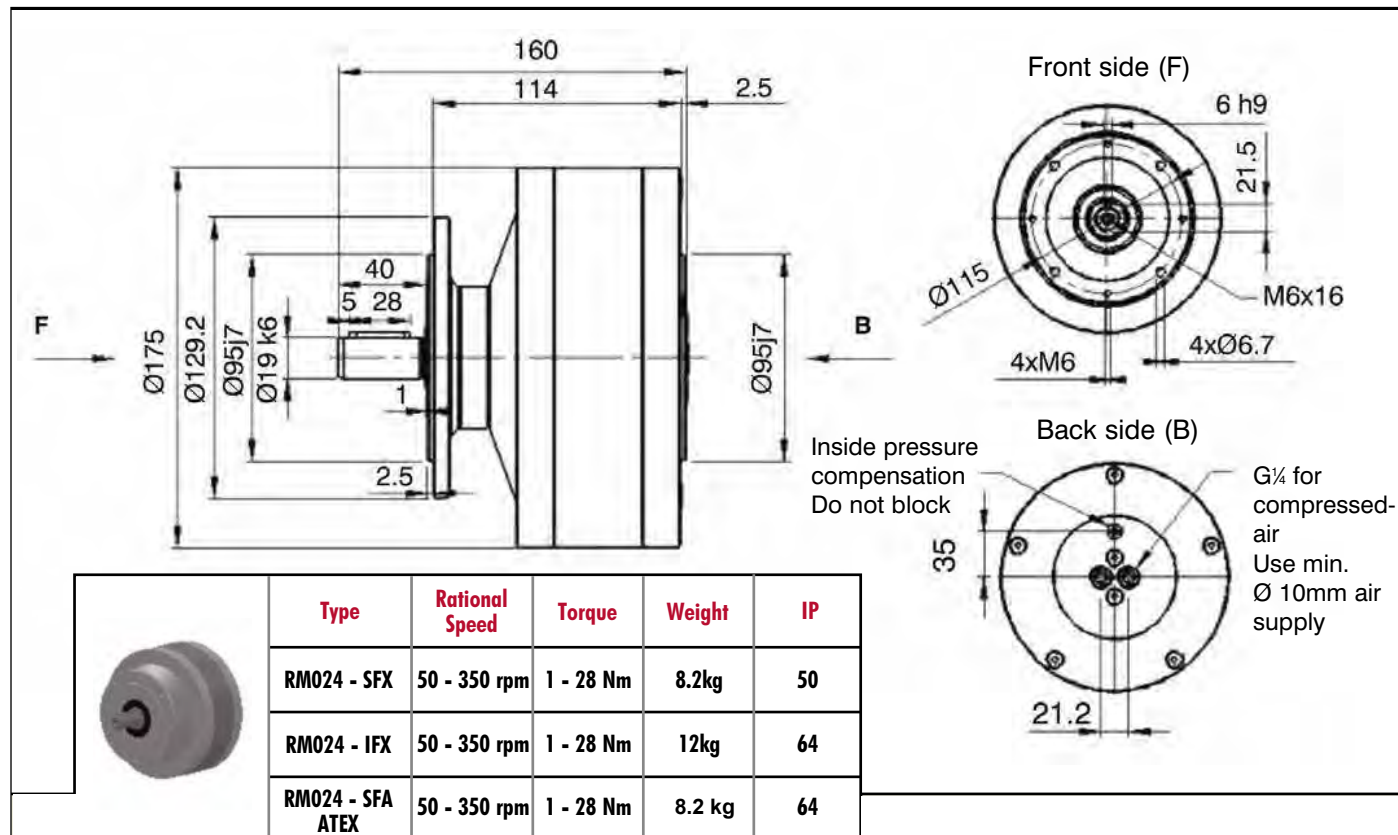

LOAD DIAGRAM FOR RM024 SFX, IFX, SFA

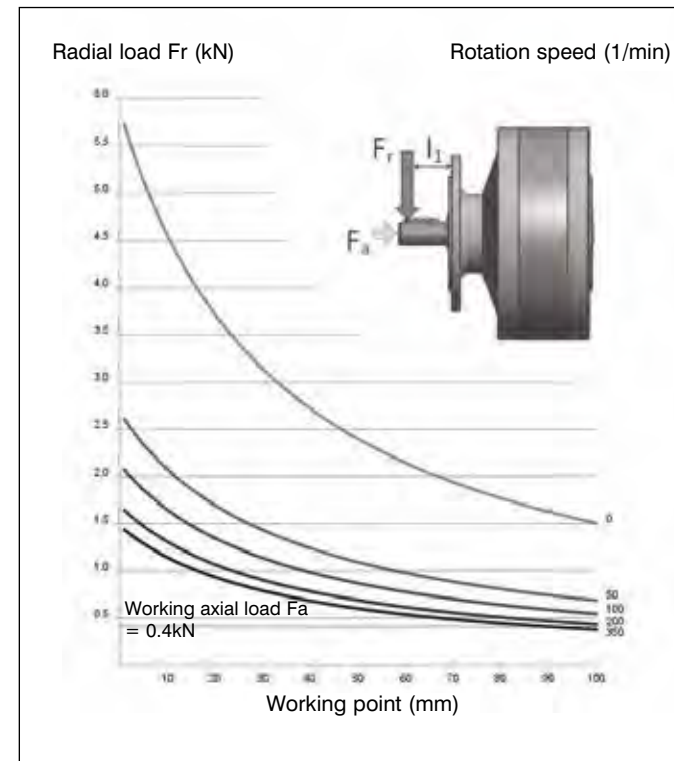

LOAD DIAGRAM FOR RM024 SXX, IXX, SXA

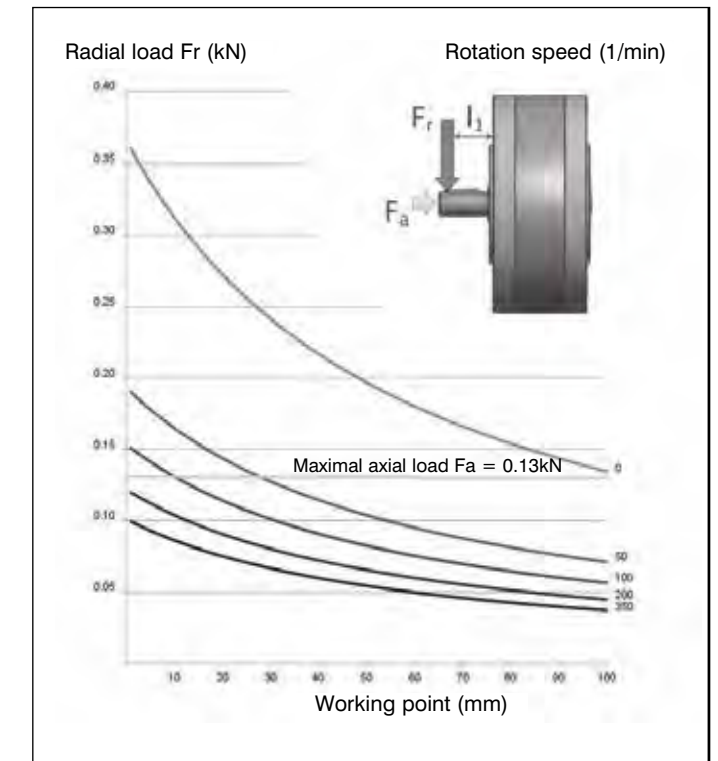

DIMENSIONS RM048 - SXX, SXA ATEX, IXX, IXA ATEX

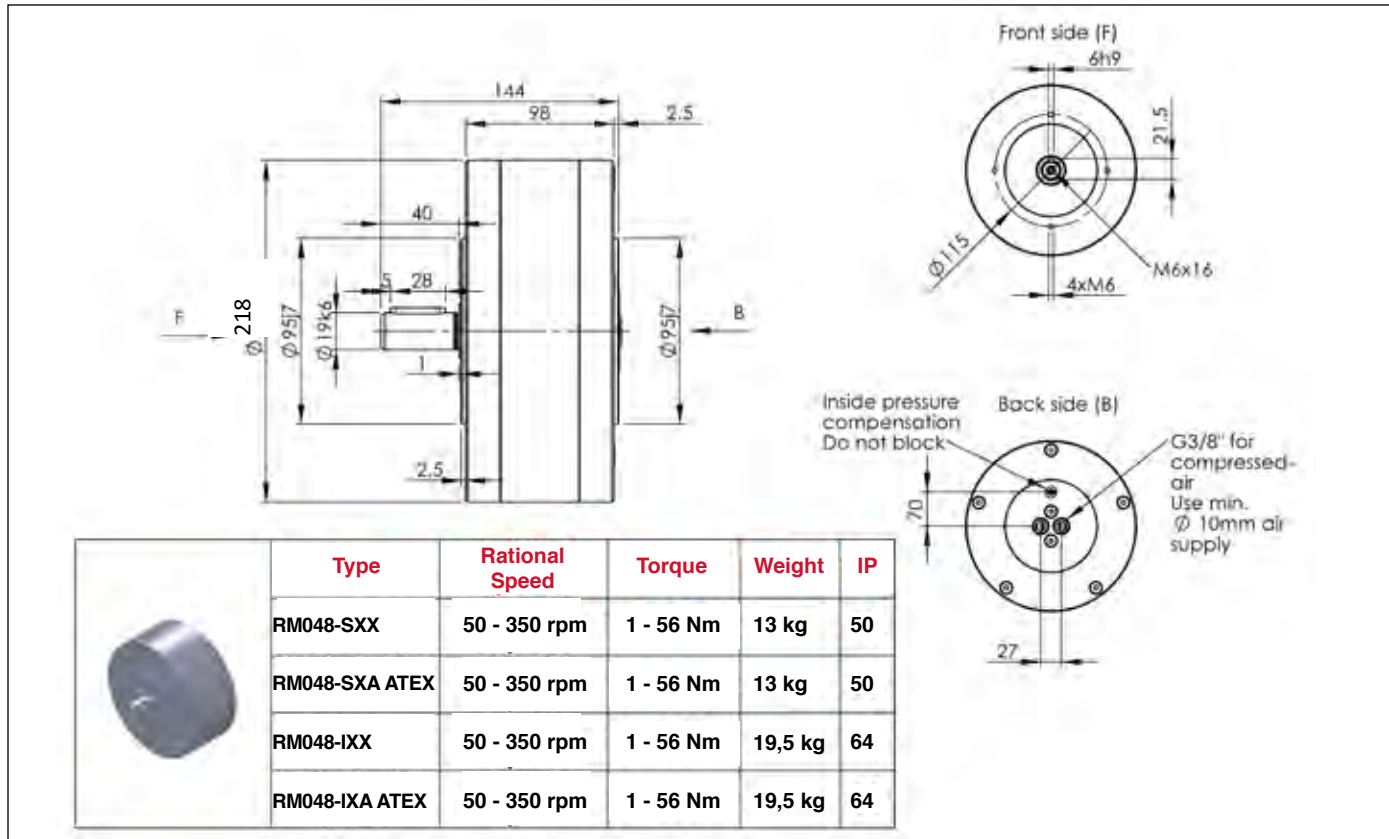

PERFORMANCE RM048

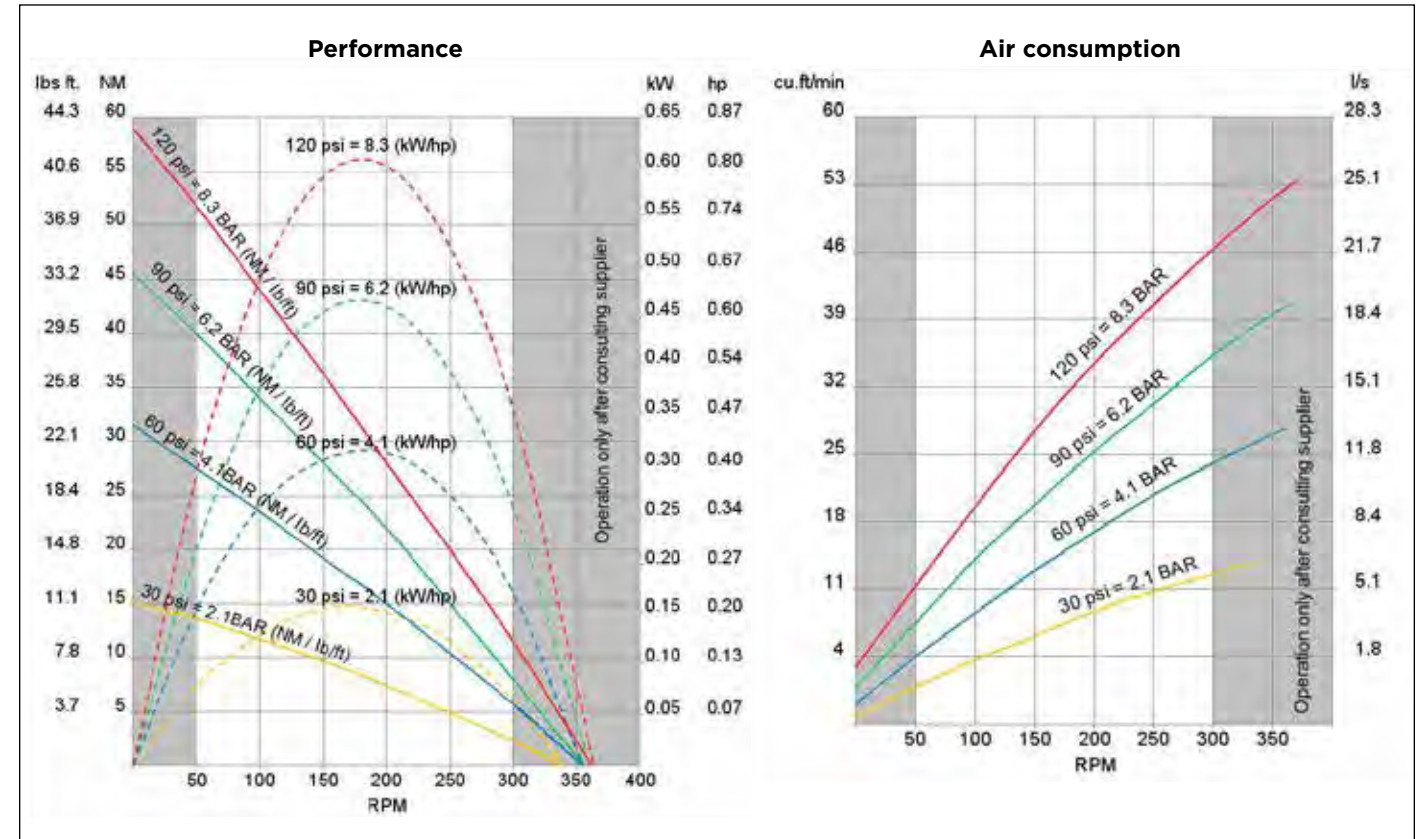

DIMENSIONS RM048 - SFX, SFA ATEX, IFX, IFA ATEX

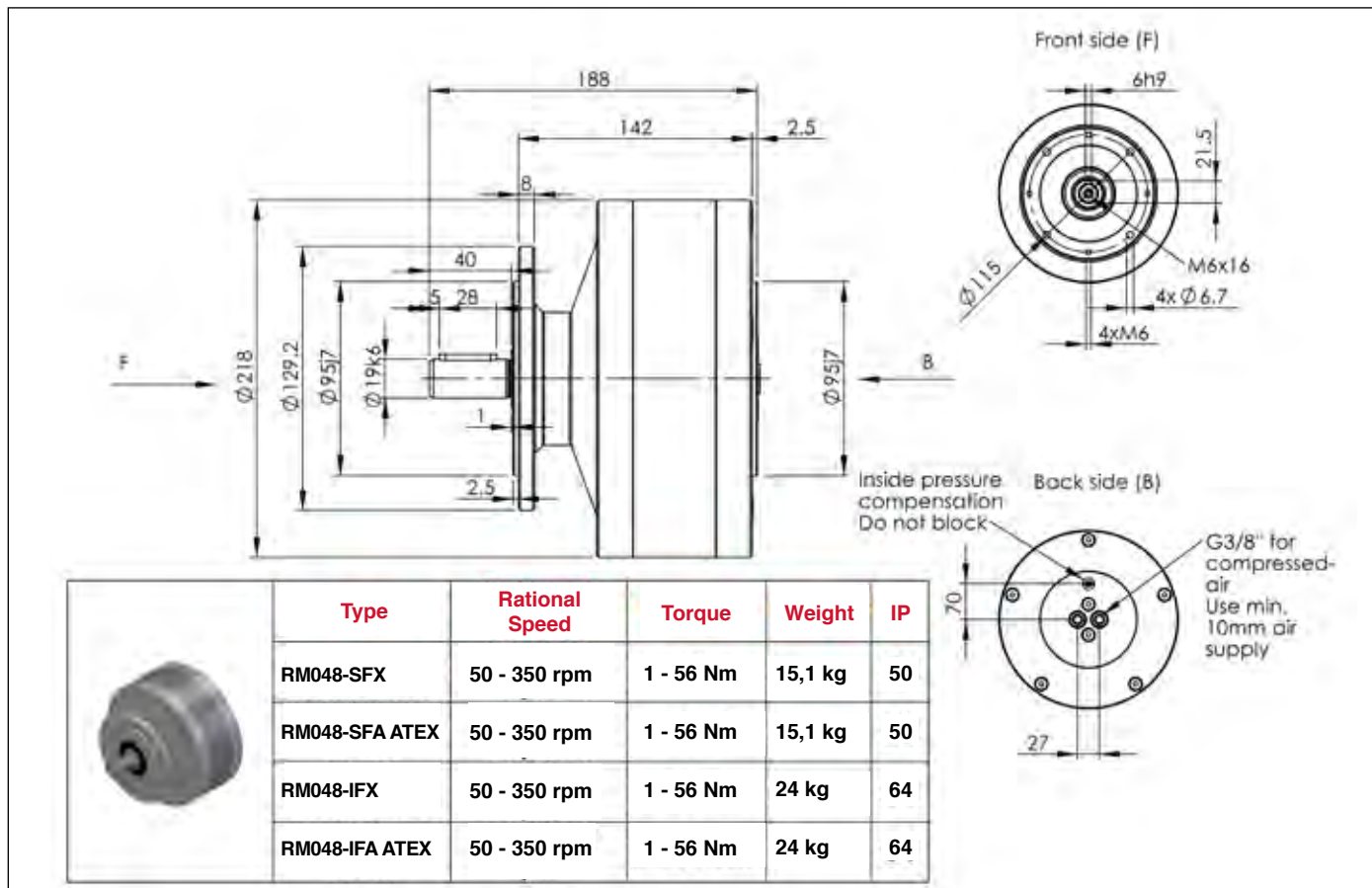

GLOBE Airmotors BV has a wide range of pneumatic brakes which can be mounted onto our compact piston

air motors. For more information contact your GLOBE Airmotor supplier.



GLOBE BN brakes are fail-safe brakes (spring engaged, air released). They can be used as a static brake and under certain conditions in dynamic applications. The brake module bolts directly onto the motor mounting face with an IEC or NEMA connection flange. The brakes are certified according to the European Explosive Directive ATEX II cat. 2 G&D T3 (in static applications only).

- Easy interchangeable because of independent brake module;
- Cast-iron or steel housing and excellent thermal capacity for use in harsh environments;
- Long life-time;
- Certified according to the European Explosive Directive ATEX II cat. 2 G&D T3.

THE ADVANTAGES OF THE BN BRAKES INCLUDE:

- Brake can be used in dynamic applications;
- Field serviceable;
- Easy flange connection according to IEC and NEMA standards;
- Low maintenance because very few parts are exposed to wear;
- Compact design;

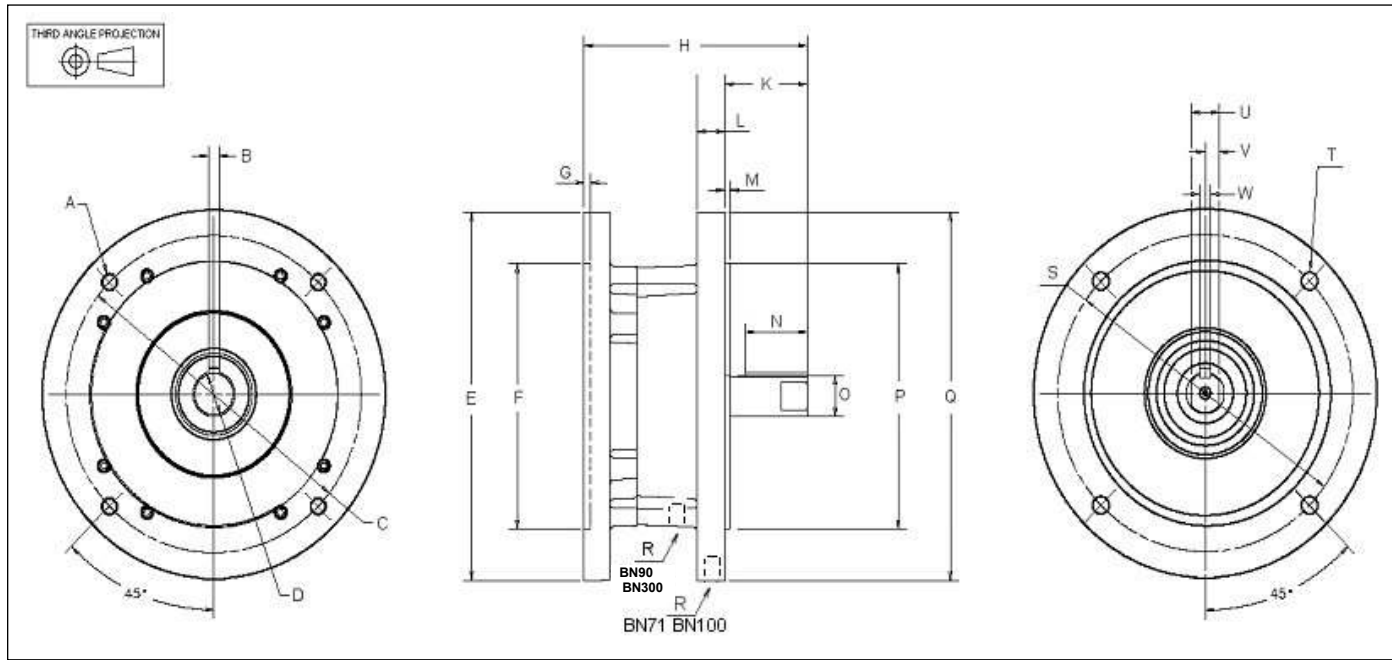

Brake type	A Ø	B	C Ø	D Ø	E Ø	F Ø	G	H	K	L	M	N	O Ø
BN71	10 (0.39")	5 (0.19")	130 (5.12")	14h7 (0.55")	160 (6.30")	110h7 (4.33")	3.5 (0.14")	137 (5.39")	30 (1.18")	44.6 (1.76")	2.3 (0.09")	25 (0.98")	14h7 (0.55")
BN90	M10	8 (0.31")	165 (6.49")	24h7 (0.94")	200 (7.87")	130h7 (5.12")	5 (0.19")	195 (7.67")	50 (1.97")	13 (0.51")	3.5 (0.14")	45 (1.77")	24h7 (0.94")
BN100	M12	8 (0.31")	215 (8.46")	28h7 (1.10")	250 (9.84")	180h7 (7.08")	5 (0.19")	163 (6.41")	60 (2.36")	19 (0.75")	4 (0.16")	55 (2.16")	28h7 (1.10")
BN300	M14	10h9 (0.39")	265 (10.43")	38h7 (1.49")	300 (11.81")	230h7 (9.05")	4 (0.16")	234 (9.21")	79 (3.11")	-	4 (0.16")	55 (2.16")	38h7 (1.49")

Brake type	P Ø	Q Ø	R	S Ø	T Ø	U	V	W
BN71	110h7 (4.33")	160 (6.30")	1/8 BSP	130 (5.12")	10 (0.39")	11 (0.43")	5.5 (0.21")	5 (0.19")
BN90	130h7 (5.12")	200 (7.87")	1/8 BSP	165 (6.49")	12 (0.47")	18 (0.71")	9 (0.35")	8 (0.31")
BN100	180h7 (7.08")	250 (9.84")	1/8 BSP	215 (8.46")	14 (0.55")	20.6 (0.81")	10.3 (0.40")	8 (0.31")
BN300	230h7 (9.05")	300 (11.81")	1/8 BSP	265 (10.43")	M14	20.6 (0.81")	10.3 (0.40")	8 (0.31")

Brake type	Flange type	Holding torque	Release pressure
BN71	IEC71 (B5)	14Nm / 10.3 lb-ft	3.4 bar / 50 psi
BN90	IEC90 (B5)	29Nm / 21.4 lb-ft	3.4 bar / 50 psi
BN100	IEC100 (B5)	75Nm / 55.3 lb-ft	3.4 bar / 50 psi
BN300-4	IEC132 (B5)	300Nm / 221 lb-ft	2.2 bar / 32 psi
BN300-6	IEC132 (B5)	450Nm / 332 lb-ft	3.2 bar / 46 psi
BN300-8	IEC132 (B5)	600Nm / 442 lb-ft	4.3 bar / 62 psi

The brake releases with pneumatic pressure. When the pneumatic pressure drops below a pre-set air pressure the brake engages.

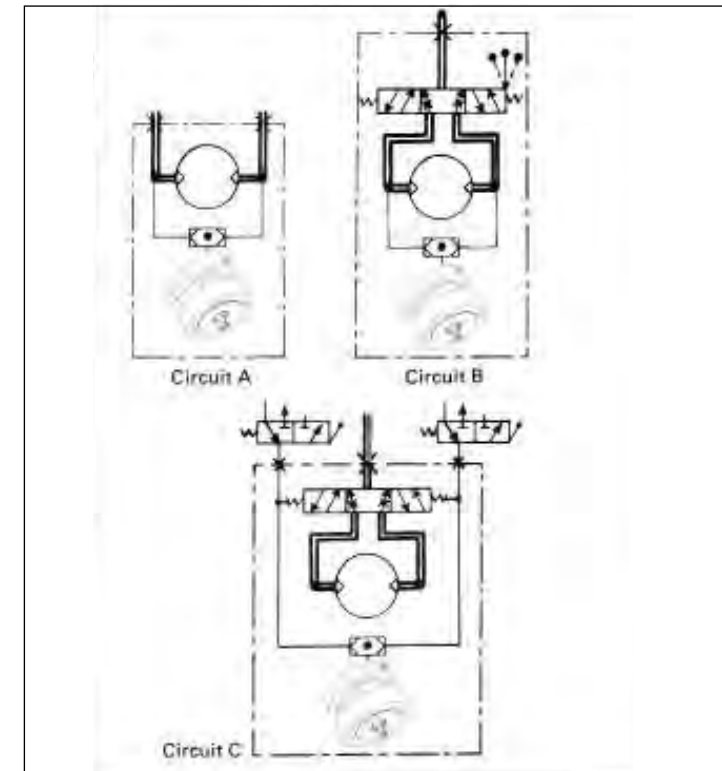

- CIRCUIT (A):** installation without control valve. The shuttle valve allows brake operation for dual rotation.
- CIRCUIT (B):** Installation with hand control valve (HCV). The HCV controls the rotation direction of the output shaft. The shuttle valve allows brake operation for dual rotation.
- CIRCUIT (C):** Installation with remote controlled valve (RCV). The RCV makes it possible to change the rotation direction of the shaft from a distance. The shuttle valve allows brake operation for dual rotation. If you need help or advice on how to correctly instal the piping for the brake release please contact us. Note - please make sure the brake has enough air pressure to release at all time.

SECTION DRAWING GLOBE BN71 AND BN90 BRAKE

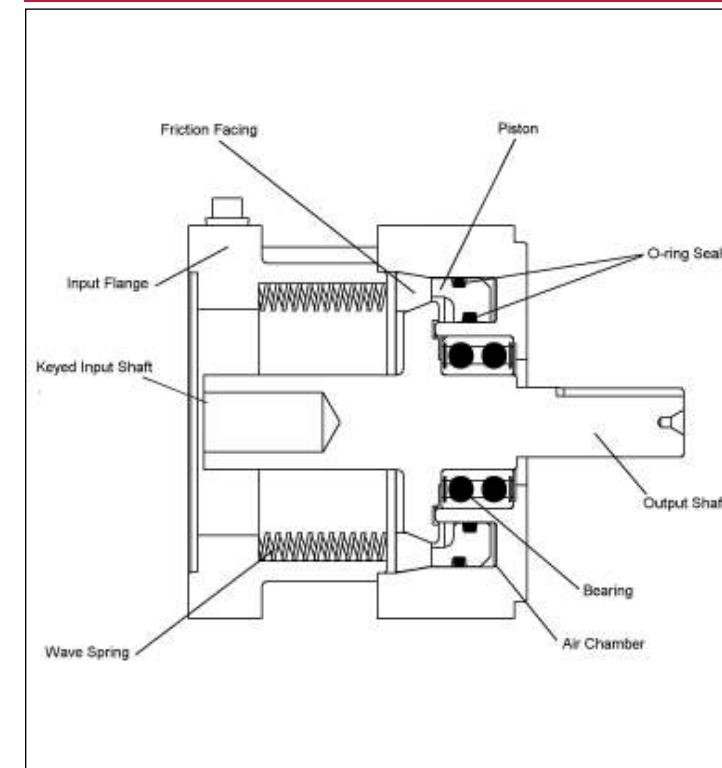

SECTION DRAWING GLOBE BN100 BRAKE

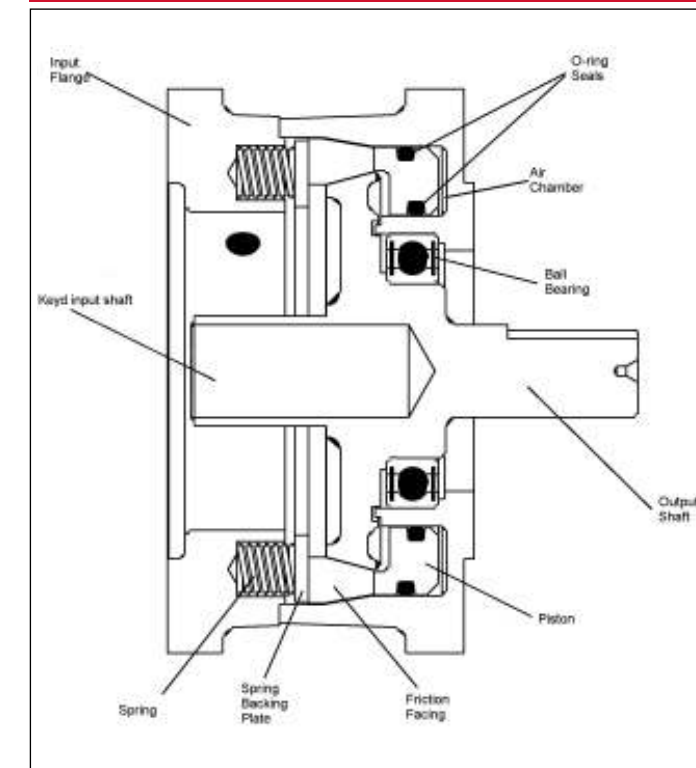

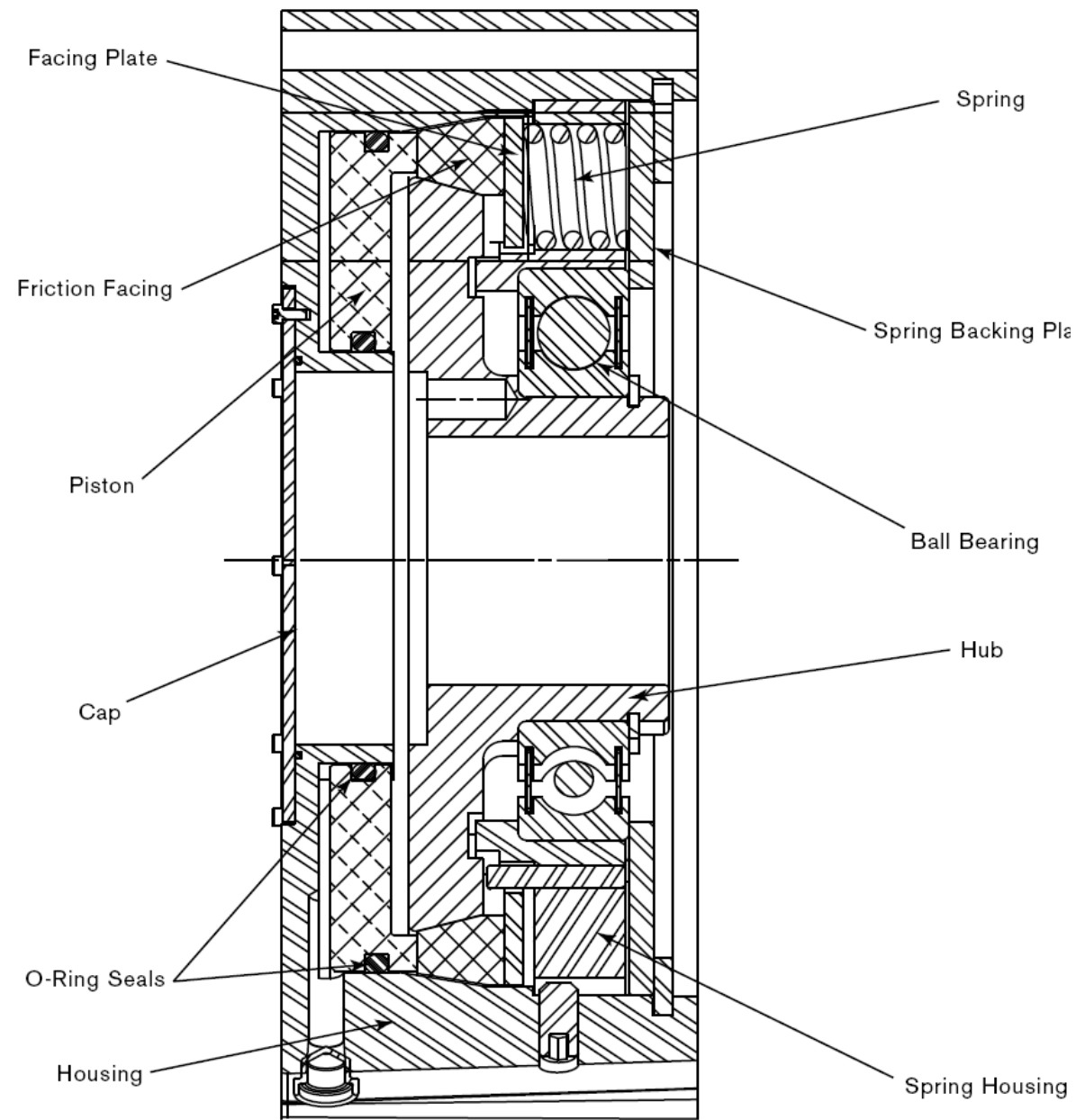

WINCH SYSTEM

Our air motors are used a lot in winching applications. Due to a growing demand for a complete pneumatic control system combined with an air motor drive, GLOBE Airmotors developed the winch system completely certified with ATEX II Cat. 2 G&D T3.

The winch system is a custom build system, which can be build according to the specific demands required for each individual project. The following parts or options can be included in the winch system: Stainless steel control cabinet, limit switch, air motor, pneumatic brake, gearbox, pendant control and a control valve.

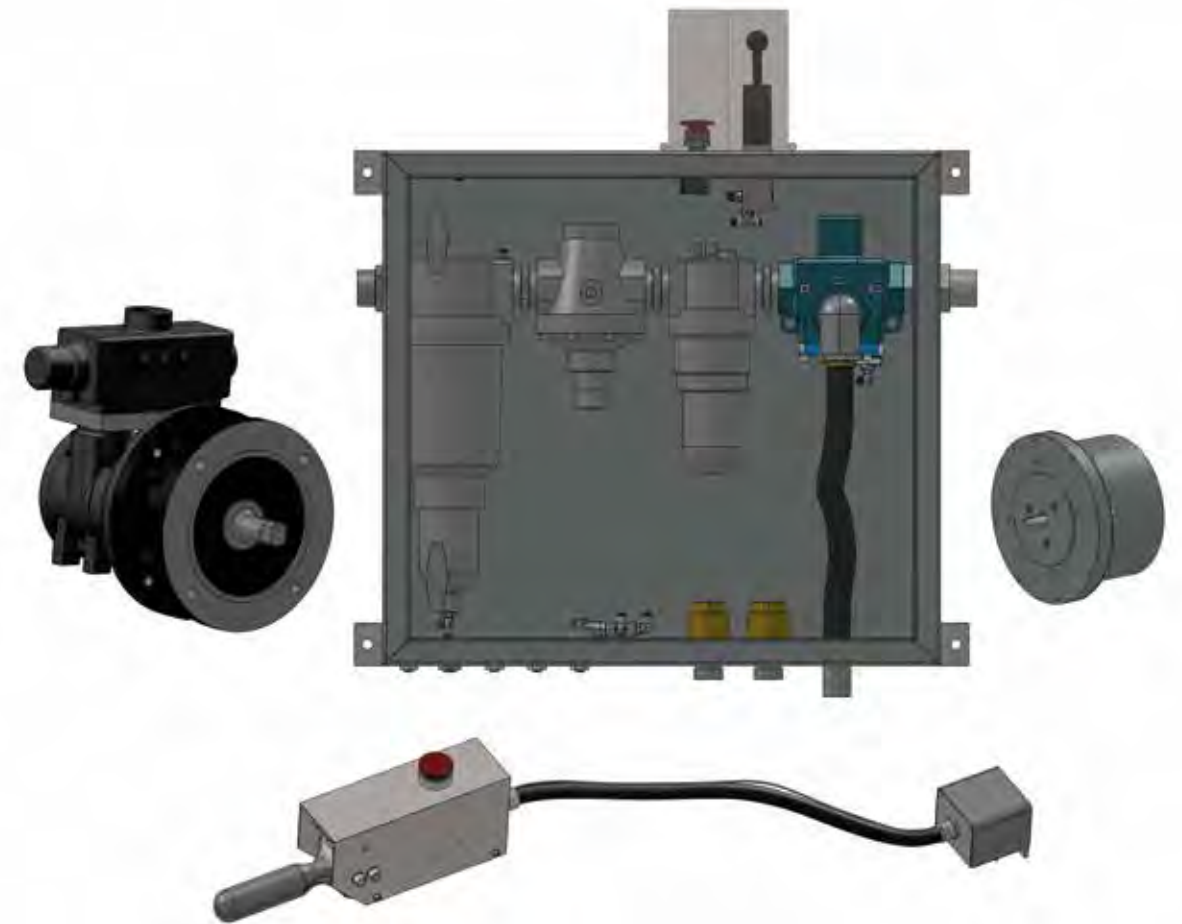

STAINLESS STEEL CONTROL CABINET

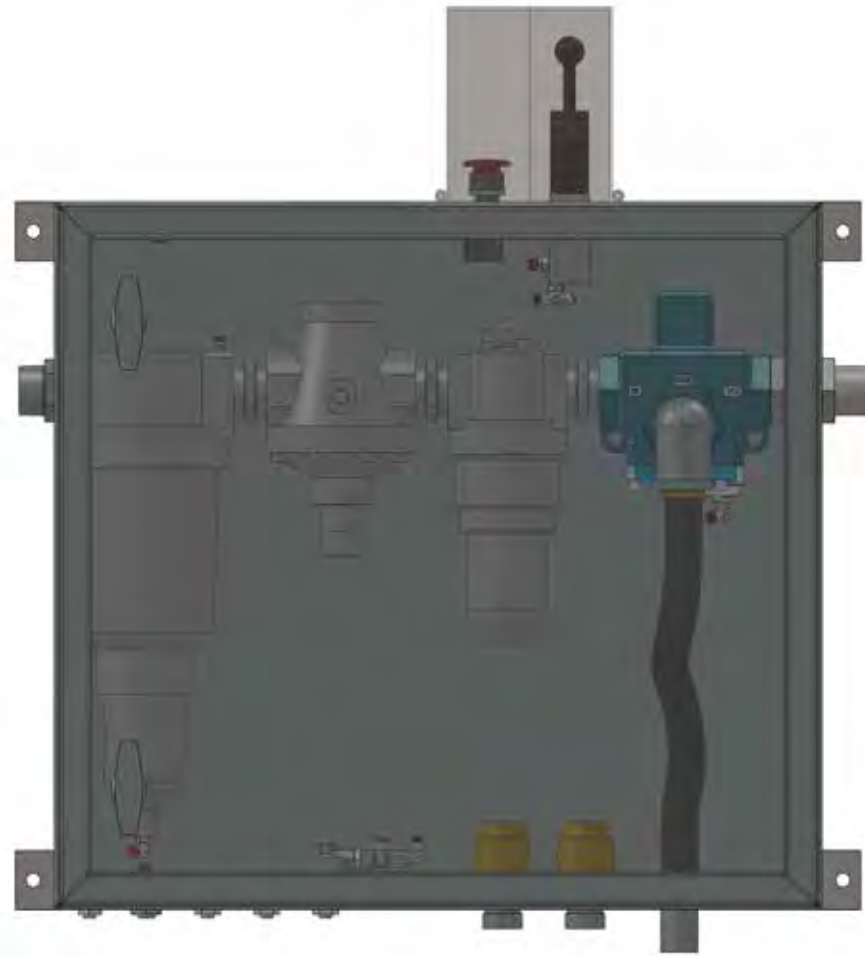

The stainless steel cabinet is the main control cabinet for the winch system. The cabinet is placed in the main air supply line and is connected to all the other controlling parts for the system. The cabinet includes the following options:

GFRL-FRL UNIT

This is a combination unit consisting off a filter, reducer and lubrication unit. This unit provides the air motor from clean, controllable and lubricated air to ensure the best running conditions for the air motor.

3 WAY 3/2 ON AND OFF VALVE

This valve controls the air going to the air motor. Directly connected to the 3/2 valve, are the on/off buttons and the emergency stop. With these buttons, which are also build in the control cabinet, you can ensure a safe start or stop of the system.

LC-2 LEVER CONTROL

The LC-2 can be used to control the direction of rotation of the air motor from the control cabinet.

AIR MOTOR UNIT



The air motor unit consists off the following options:

AIR MOTOR

GLOBE Airmotors sells a lot of different air motors which can be used on winching applications. Please check the rest of our brochure or contact us so we can assist you in choosing the right air motor.

PNEUMATIC BRAKE

The pneumatic brake is a fail-safe brake which is mounted directly onto the air motor. The pneumatic brake is released by air pressure and allows you to safely stop the air motor.

CONTROL VALVE

There are two types of proportional control valves which can be mounted directly onto the air motor unit. You can choose between a hand controlled valve or a remote

controlled valve. The hand control valve allows you to control the speed and the direction of rotation directly from the motor. The remote control valve allows you to control the speed and the direction of rotation from a distance. The remote control valve can be combined with a LC-2 lever control or a PC-2 pendant control.

GEARBOX

GLOBE Airmotors uses a wide range of gearboxes which can be combined with the air motor to deliver the required speed and torque.

PIPING

We can provide the air motor unit with suitable piping between the control valve and the brake so the brake is released when the control valve is being used. When the control valve goes back to neutral the pressure to the brake will be released and the brake will hold the load.

PC-2 PENDANT CONTROL

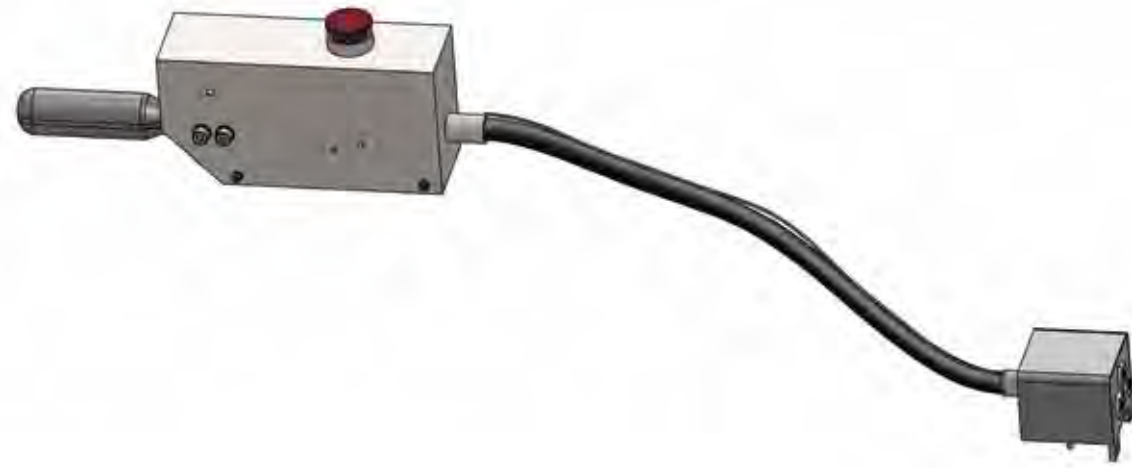

The PC-2 pendant control is connected to the air motor unit and is used to control the motor through the remote control valve from a distance. We can supply the PC-2 pendant control with a stainless steel cover and a build

in emergency stop. The emergency stop shuts off the main air supply to the air motor unit when pressed to ensure a safe use even at a distance.

LIMIT SWITCH



The limit switch is directly mounted onto the winch and is used to stop the winch at a pre adjusted moment. For example when you have an application in which the winch can only rotate 20 times. You can set the limit

switch to 20 rotations, so the limit switch will give a signal to the control cabinet to shut down the system when these 20 rotations are obtained. The limit switch is an extra safety option for your winching application.

AIR MOTOR MOUNTED ON A WINCH

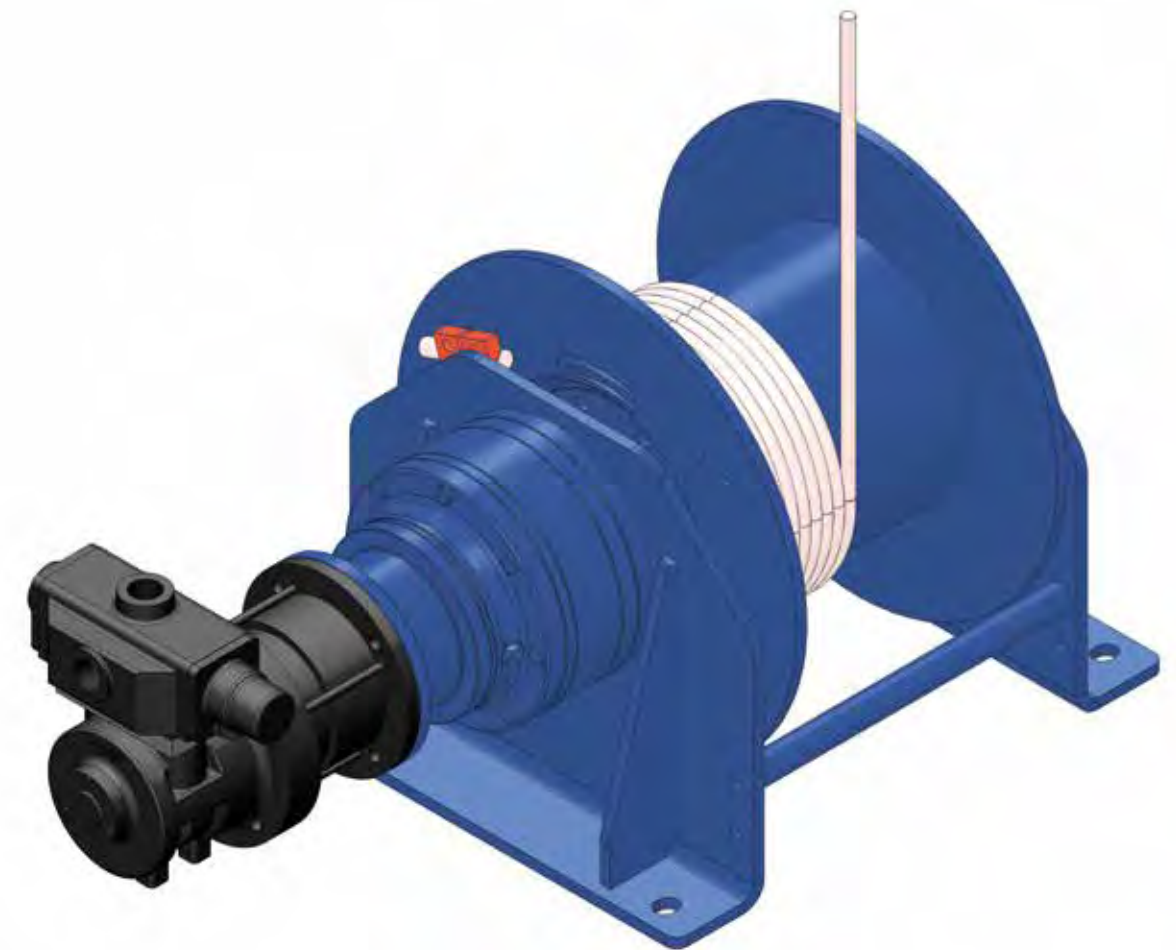



STAINLESS STEEL MOTORS AND ACCESSORIES

Due to the growing demand for stainless steel air motors GLOBE Airmotors is constantly working to meet these demands by introducing more and more stainless steel air motors. Keeping our motors on stock is very important for our customers, therefore GLOBE is putting

much effort in keeping stock of stainless steel motors as well. Please see which stainless steel air motors GLOBE keeps on stock and which options are possible. Do not hesitate to contact us for any other stainless steel options.

STAINLESS STEEL VANE MOTORS

The following stainless steel vane air motors are available directly from stock:

Stainless steel vane air motor
VS4CI
VA4CI
VS6CI

These stainless steel vane motors have the same dimensions and performances as the standard version of the vane air motors. If you require other stainless steel

vane air motors, please contact us for more information and possibilities.



STAINLESS STEEL COMPACT PISTON AIR MOTOR

The following stainless steel compact piston motors are available directly from stock:

Stainless steel compact piston air motor
RM012-PXX
RM012-PFX
RM024/RM048-IXX
RM024/RM048-IFX



STAINLESS STEEL COMPACT VANE AIR MOTOR

The following stainless steel compact vane air motors are available directly from stock:

Stainless steel compact vane air motor
2M02RS
2M10RS
5M05RS
5M34RS



GFRL-FRL STAINLESS STEEL (FILTER, REDUCER AND LUBRICATOR) UNIT

Please contact us for the availability of the stainless steel GFRL-FRL unit. We can supply the following range of FRL units:

Stainless steel GFRL-FRL unit
G1/8" until G1" (2 piece unit)
G1 1/4" until 2" (3 piece unit)



World Headquarter

GLOBE Airmotors BV

Boerhaaveweg 9-11
2408 AD, Alphen aan den Rijn
The Netherlands

Tel: +31 (0)172 - 42 66 08

Fax:+31 (0)172 - 42 66 07

info@globe-benelux.nl

Germany

GLOBE Luftmotoren & Hochdrucktechnik GmbH

Schmiedestraße 23
26632, Ihlow/Riepe
Germany

Tel: +49 (0)4928-9151 606

Fax: +49 (0)4928-9151 608

info@globelh.de

Distributed by:

PLEASE VISIT US AT WWW.GLOBE-BENELUX.NL



GLOBE AIRMOTORS B.V.